

FAIRBANKS®

ULTEGRA® SERIES DIGITAL HEALTH SCALES

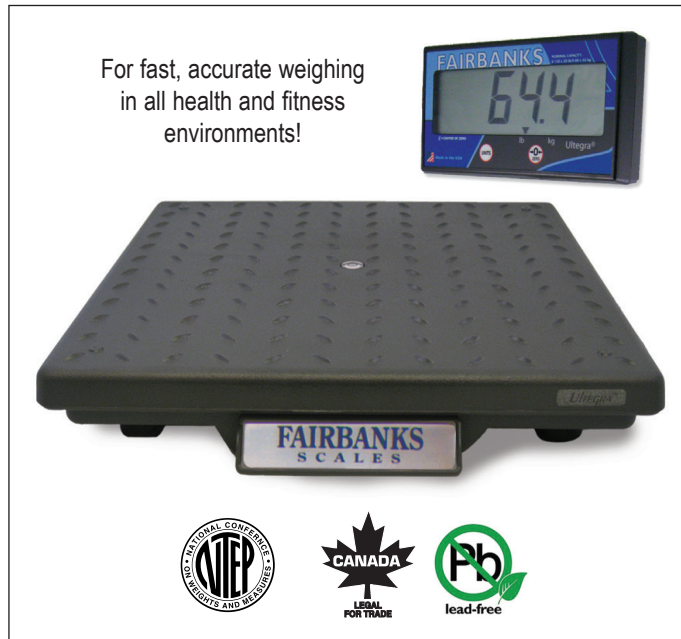

Fairbanks' Ultegra Series Digital Health Scales are ideal for use in doctors' offices, weight loss centers and sports facilities.

FEATURES

- Each Ultegra Series Health Scales come with a large, easy-to-read, 1 ½" tall LCD remote display.
- User-friendly 14" x 14" platform.
- Two button operation.
- Scale's low profile (less than 2.5") makes it easy to step on and off.
- Lightweight design for easy mobility.
- Weigh in pounds or kilograms.

SPECIFICATIONS

Capacity	.600 lbs
Division size	.600 x 0.2 lbs
Construction	Gray, ABS composite
Remote display	1 ½" tall LCD
Net weight	6.5 lbs
Power requirements	USB powered, AC adaptor included
Accessories	Remote display pillar stand
Approvals	NTEP CC# 98-198, MC #AM-5298, RoHS

DIMENSIONS

Scale Platform

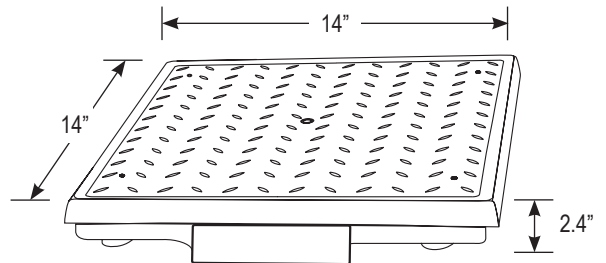

Remote Display

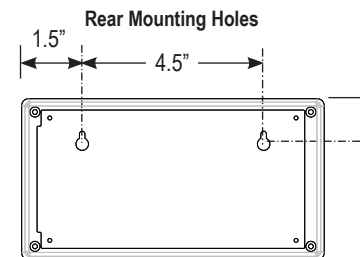
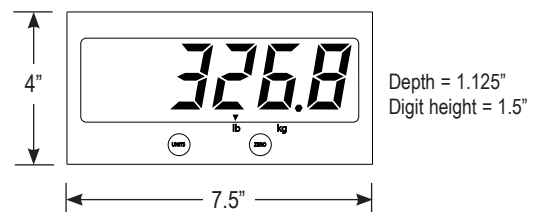

Remote Display Pillar Stand

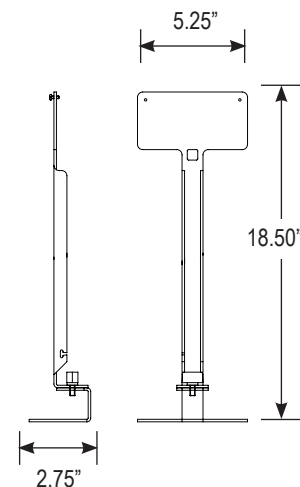

Call toll-free for the Fairbanks representative nearest you:

(800) 451-4107

QuickFacts™

Models and specifications subject to change without notice.

© Fairbanks Scales Inc.
www.Fairbanks.com