

FAIRBANKS®

1200 SERIES PORTABLE UTILITY SCALE



Fairbanks' 1200 Series combines digital electronics with reliable, mechanical weighing to create a general purpose, 1,000 pound capacity, utility scale that is approved for commercial applications.



ECONOMICAL AND EASY TO USE

This portable, cast iron scale runs on AC or battery-power, enabling it to operate virtually anywhere. Easy-rolling wheels and a new, non-slip, ergonomic handle make moving the scale a simple task.

APPLICATIONS

- Material handling
- Inventory management
- Parts distribution
- Warehousing
- Auditing
- Bag filling

FEATURES

- Sturdy cast iron base, lever system, platform and wheels provide years of accurate service.
- Made for easy portability with cast iron wheels and new, non-slip, ergonomic handle.
- Battery or AC power.
- Fairbanks' low-power technology enables batteries to last through 34 hours of continuous use.
- 2.0" backlit LCD is easy to read in most lighting conditions.
- NTEP and MC approved for "Legal for Trade" applications.

SPECIFICATIONS

Capacity	1000 x 0.2 lb
Display	2.0" tall, 6-digit, selectable, backlit LCD
Enclosure	Black, resin alloy, NEMA 4 rated
Push-button keys	On/Off, Units, Zero, B/G Net, Tare, Print, F1
Units	lb, kg, oz, g, ton, tonne, custom
Communications	COM 1 - Bidirectional RS232/transmit only 20mA COM 2 - Bidirectional RS232/transmit only RS485
Power	AC or rechargeable battery
Approvals	NTEP CC# 92-110, MC #AM-5720

DIMENSIONS (in inches)

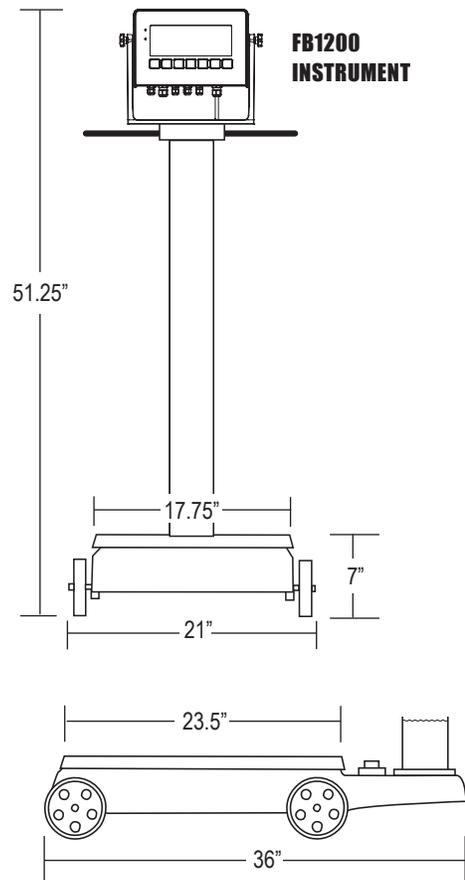

QuickFacts™

Models and specifications subject to change without notice. Printed in the USA.
© Fairbanks Scales Inc.
www.Fairbanks.com

Call toll-free for the Fairbanks representative nearest you:
(800) 451-4107