

FAIRBANKS®

S C A L E S



NEXWEIGH
CHECKWEIGHING INSTRUMENTS

A versatile instrument that exceeds the food and chemical industries' need for sanitary checkweighing electronics in high-pressure, high-temperature washdown environments.

Fairbanks.com

NexWEIGH

CHECKWEIGHING INSTRUMENTS

FAIRBANKS SCALES IS DEDICATED TO DEVELOPING INNOVATIVE WEIGHING PRODUCTS THAT ARE DURABLE AND DEPENDABLE.

NexWeigh checkweighing instruments are made to meet the food and chemical industries' need for sanitary checkweighing electronics that withstand high-pressure, high-temperature washdown environments.

The NexWeigh boasts the most visible display in the industry, with larger-than-average digits and amber LEDs that have been scientifically proven to reduce eye strain.

This instrument is highly versatile in functionality and works in conjunction with a variety of Fairbanks stainless steel bench scale platforms and pillars, as well as other analog platforms.

NEXWEIGH IP69K MODEL

Designed for heavy washdown applications including:

- Heavy washdown
- Food processing
- Batching
- System integration
- Process control
- Filling

NEXWEIGH NEMA 4X MODEL

Designed for dry-to-moderate washdown applications including:

- Checkweighing
- Food / Beverage
- Stress analysis
- Manual batching
- System integration
- Chemical

ETHERNET OPTION

Fairbanks' NexWeigh Instrument with a factory-installed Ethernet TCP/IP module provides weight information to a network and allows for detailed control of instrument functions from a remote network location.

NEXWEIGH SANITARY FEATURES

- Stainless steel construction.
- No product or liquid collection points.
- Can be cleaned to a microbial level.
- Special overlay resists punctures and abrasive cleaning agents.
- Fairbanks and Ecolab worked together to create a defined cleaning protocol.



Manufactured by Fairbanks
in St. Johnsbury, Vermont

"Under" weight
range represented
by 12 amber LEDs

"Acceptable"
weight range
represented by
12 green LEDs

"Over" weight
range represented
by 12 red LEDs

Stores up to
four over/under
checkweighing
ranges for
quick access.

A bright,
amber LED is
displayed for
the active
over/under
setting

Front panel
for program
and calibration

Desk/ wall
mount bracket

The NexWeigh's GORE-TEX™
vent keeps water out, while
allowing pressure and gasses
inside the instrument to escape.

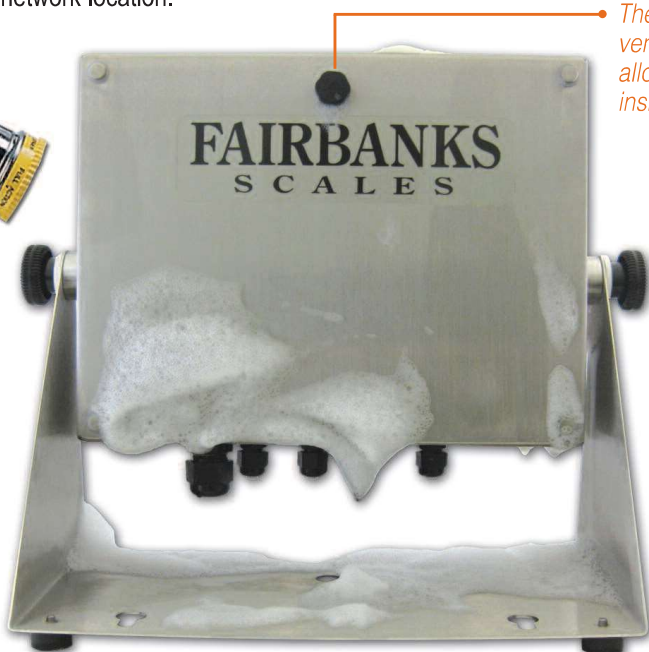

NEXWEIGH OPERATIONAL FEATURES

- Four programmable checkweigh ranges.
- Peak Hold feature captures the highest weight value recorded.
- Seven selectable LED intensity settings.
- Multi-point calibration.
- Three remote switches.

FAIRBANKS[®] S C A L E S

WEIGHING SOLUTIONS FOR THE WORLD SINCE 1830.

NEXWEIGH SPECIAL FEATURES

Large 1.25",
seven-segment digits

Intensity
selectable

Units include:
pounds, ounces,
kilograms, grams,
pounds/ounces or
any custom unit

Easy-to-see amber LEDs



Access
naming
notation

Oversized pushbutton
keys promote easy operation

Visual reference
when total
accumulations
are displayed

Optimal sanitary checkweigher



While the NexWeigh is versatile enough for use in a variety of applications, it is ultimately a premium checkweighing instrument due to its sanitary design, commercial approval, IP69K washdown rating and easy-to-use front panel checkweighing functions.



The NexWeigh IP69K Instrument
is ideal for use with Fairbanks'
Aegis[®] Lift Deck Sanitary
Floor Scale.

- Accumulation or auto-accumulate.
- Print or auto-print.
- RS232 and RS485 standard outputs.

VISIT OUR WORLD TODAY
FAIRBANKS.COM/NEXWEIGH

NEXWEIGH

CHECKWEIGHING INSTRUMENTS

Weighing Solutions for the World Since 1830

Fairbanks.com

SPECIFICATIONS

Display	1.25" high, 6-digit, amber LED (intensity selectable); Dedicated under/accept/over display with: 12 amber segments for under range, 12 green segments for accept range and 12 red segments for over range
Enclosure	304 stainless steel, IP69K rated; 304 stainless steel, NEMA 4X rated
Pushbutton Keys	Zero Print Units Tare B/G Net Checkweigh Program Over/Under 1-4 (programmable)
Units	lb, kg, oz, g, lb-oz or custom
Capacity	Selectable 0 to 999,999
Graduation Size	0.0001 to 50
Load Cells	Up to four 350Ω cells or eight 1000Ω cells
Power Requirements	110 VAC or 220 VAC; 50/60 Hz
Output	COM 1: RS232, COM 2: RS485, or COM 1: Ethernet TCP/IP, COM 2: RS485
Accessories	4-20 mA module
Approvals	NTEP CC# 09-024, MC #AM-5725, ETL

MOUNTING OPTIONS

- Desk / wall mount stand
- Stainless steel portable scale cart
- 10" pillar
- 18" pillar
- 30" pillar
- Short pillar

NEXWEIGH IP69K STAINLESS STEEL ENCLOSURE

(Stainless steel bracket included)

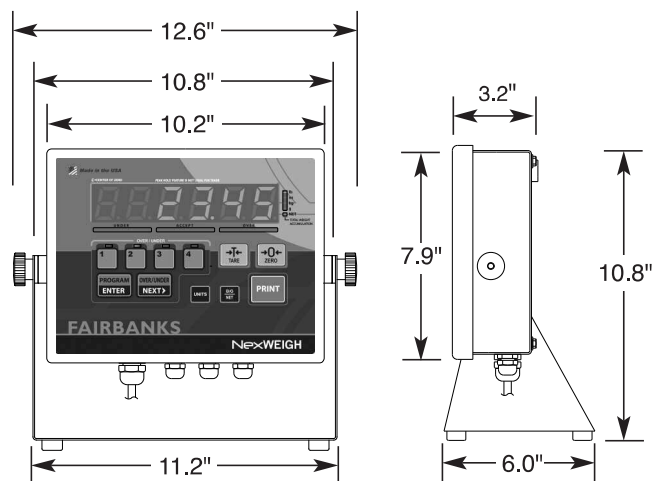

NEXWEIGH NEMA 4X STAINLESS STEEL ENCLOSURE

(Stainless steel bracket included)

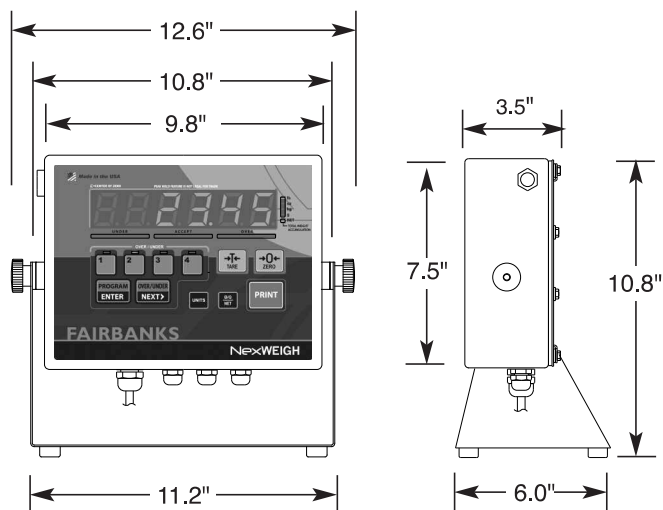

Your Fairbanks Scales Authorized Representative is:

Call toll-free for the representative nearest you:

(800) 451-4107

Call between 8:00 a.m. – 5:00 p.m. Central Time
Corporate Offices: 821 Locust • Kansas City, MO 64106 • (816) 471-0231
Internet Address: <http://www.Fairbanks.com>



St. Johnsbury manufacturing
facility registered in
compliance with ISO 9001.

