

SIDE CHECKING DETAIL

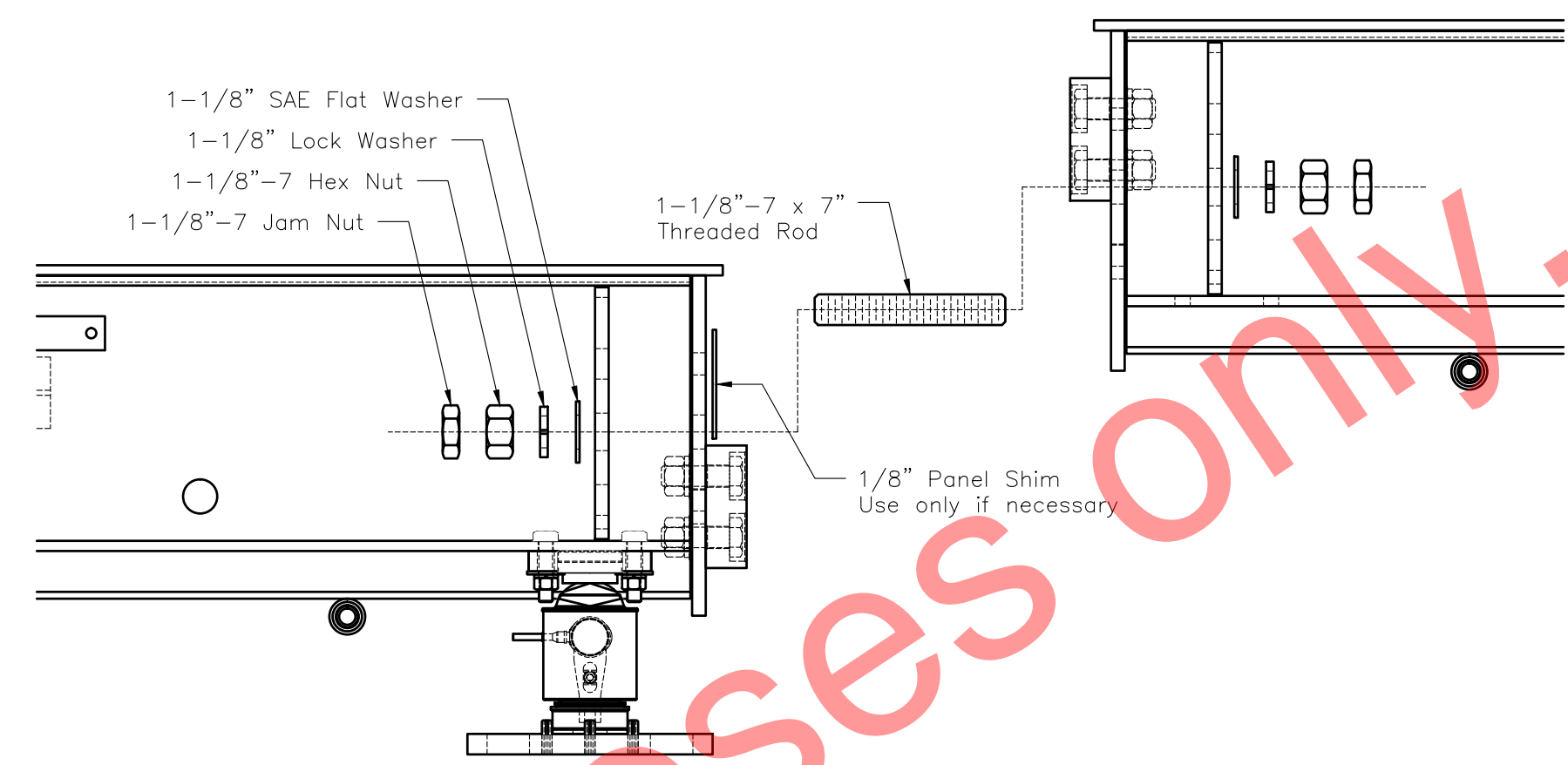

EXPLODED VIEW

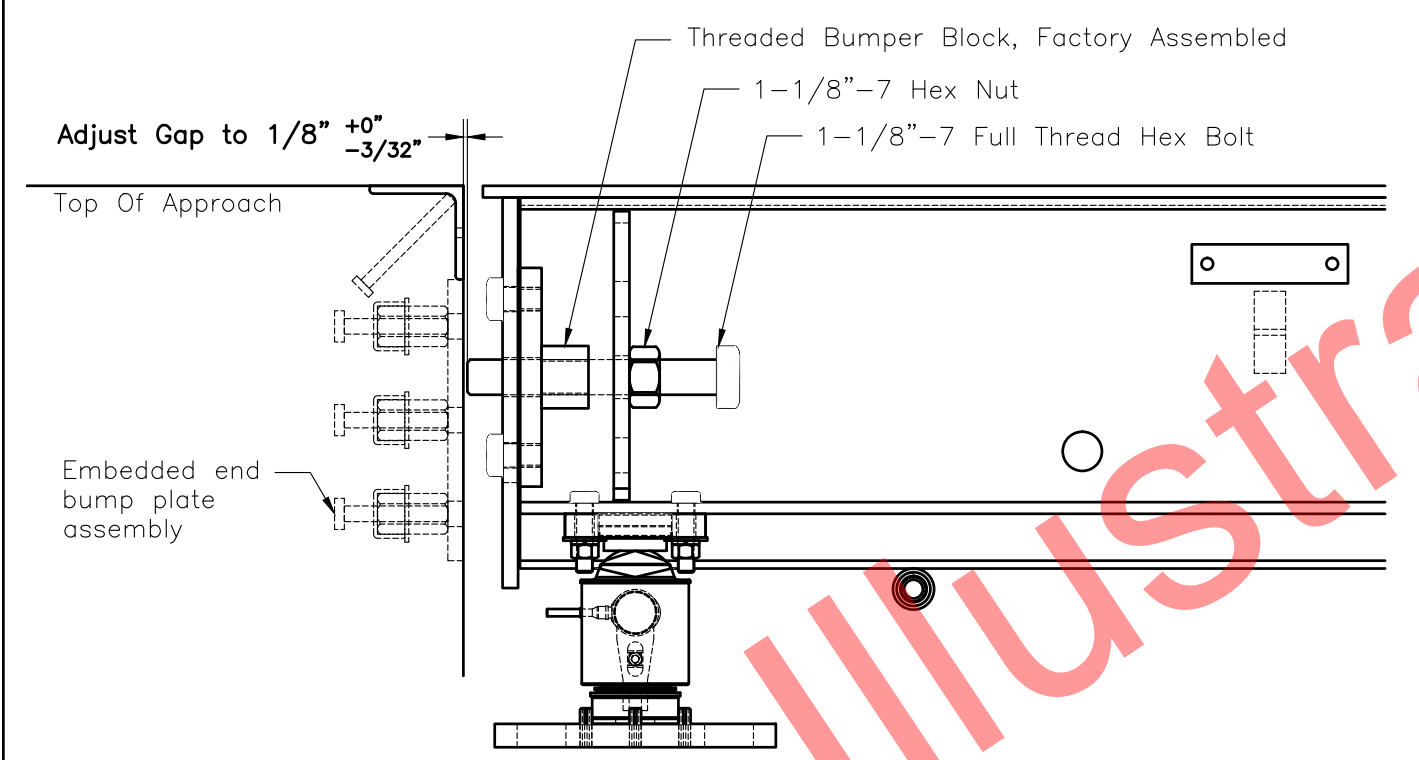

END CHECKING DETAIL

Note: Side checking hardware not shown in this view for the sake of clarity

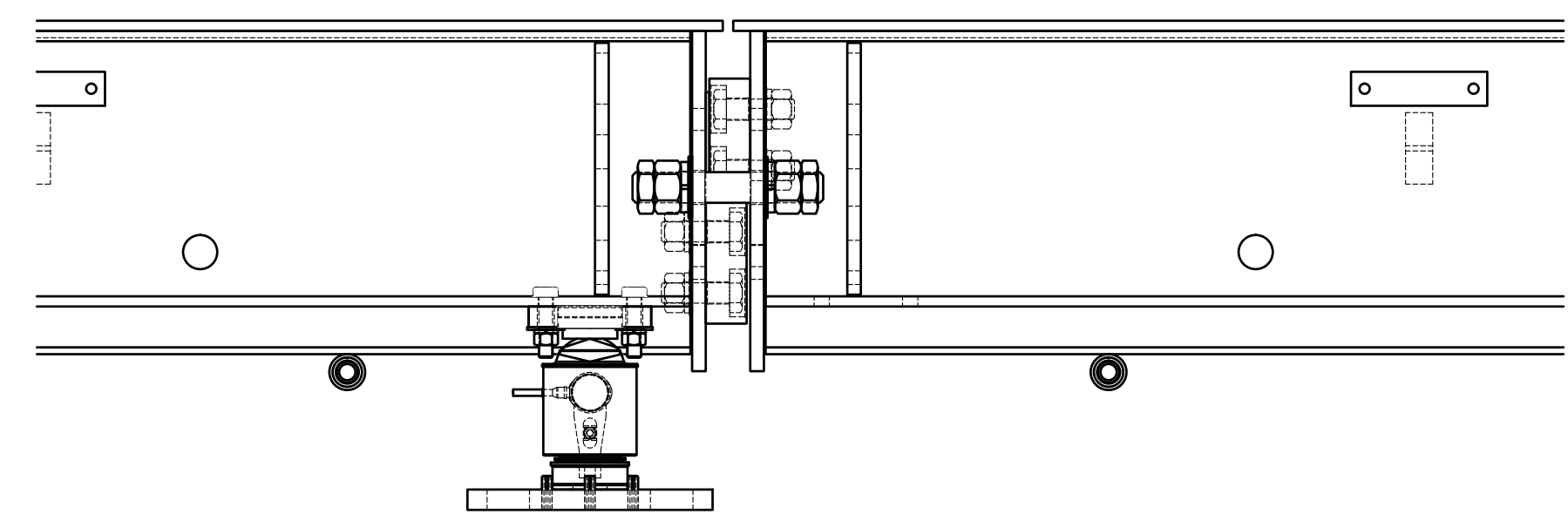

INTER-MODULE CONNECTION DETAIL
Typical at all interior sections

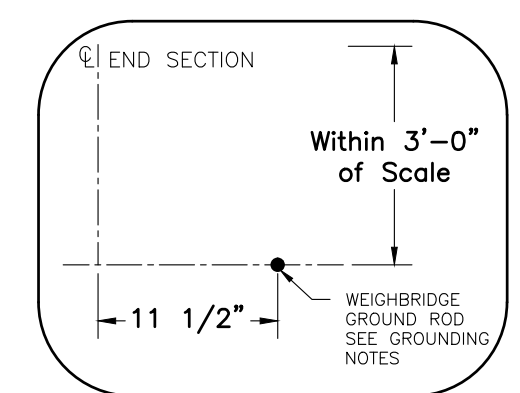

WEIGHBRIDGE GROUNDING DETAIL

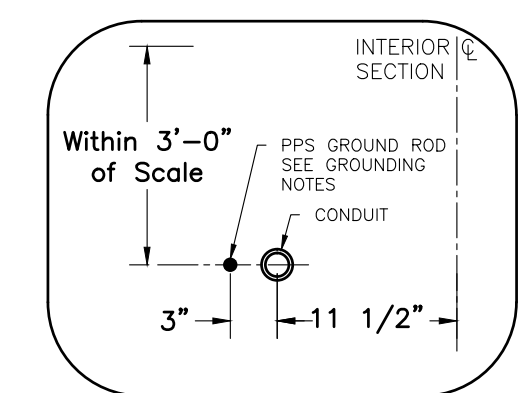

PIT POWER SUPPLY GROUNDING DETAIL

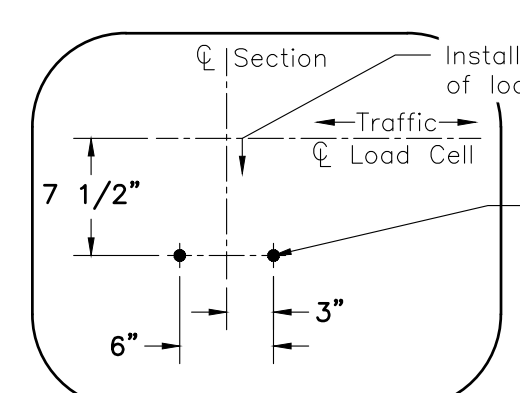

ANCHOR DETAIL

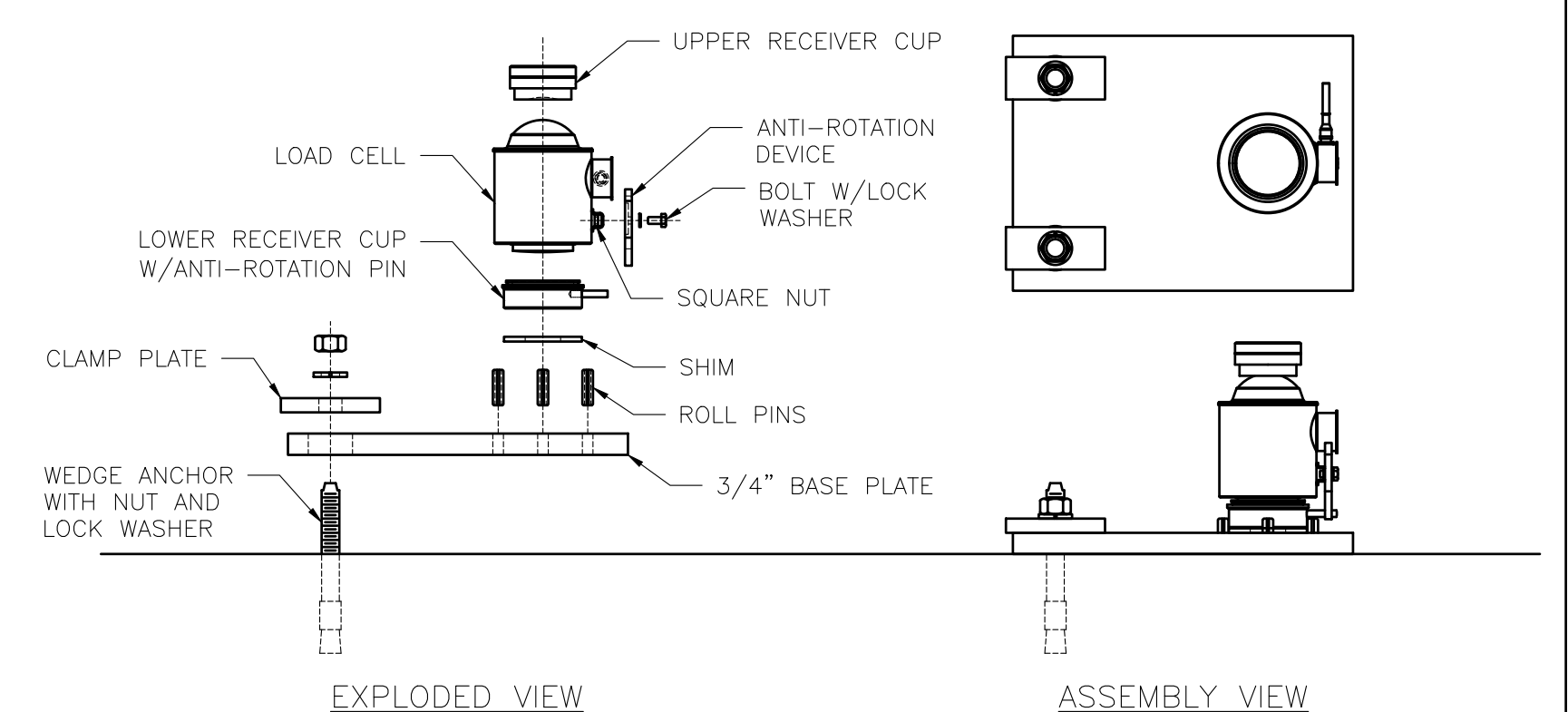

EXPLODED VIEW

ASSEMBLY VIEW

GENERAL NOTES

- N.I.S.T. H-44 requires that on the entrance and exit ends of a vehicle scale, there shall be a straight approach that is:
 - At least the width of the platform.
 - The length of at least one-half the length of the platform but not required to be more than 40ft, and
 - Any slope in the remaining portion of the approach shall ensure ease of vehicle access, ease for testing purposes, and drainage away from the scale.
- N.I.S.T. H-44 requirements and local weights and measures regulations may require installation parameters somewhat different than illustrated on this plan. In order to insure compliance, consult the local Fairbanks service office prior to installation.
- Refer to manual for all installation and operation instructions.
- Fairbanks does not recommend using foundation or ground installed guide rails along the sides of the truck scale platform. Damage may occur to the scale if the vehicle hits the guide rail, transferring damaging forces to the platform and the checking system, usage of this style guide rail will void the product warranty. If guide rails are necessary, please use fairbanks accessory rub rails.
- A minimum of 24" of clearance is required on both sides of the scale in order to access load cells, electronics, and checking hardware.
- On steel deck scale, pay close attention to deck seams when they are not centered on the width of the module. Install the scales in the proper orders and with the proper orientation to ensure that the deck seams align.

GROUNDING AND ELECTRICAL NOTES:

- Install (2) 3/4" x 8'-0" long ground rods (to project 4"). Two ground rods are supplied with scale.
 - One for grounding intalogix power supply, position to match location of conduit for cable to scale indicator (may be located on any pier adjacent to mounted PPS).
 - One for grounding scale weighbridge, power supply ground must be separate from weighbridge ground.
- Install minimum 1 1/2" conduit for cable from junction box to scalehouse. Conduit to extend 2" above the top of the pier (not supplied by fairbanks scales).
- If alternating current (ac) is required near the scale, it shall not run closer than 24" in parallel with any load cell or other signal carrying cable.

80' x 12'
Talon HVX Steel Deck Undermount
100,000lb CLC, 150ton Capacity

FAIRBANKS
Scales & Weighing Systems

SCALE: 1 OF 1
DATE: 11/20/14
DRAWING NUMBER: D172280A-SP

MODEL: PLT-6020-100-A-012-080

THE INFORMATION CONTAINED HEREIN AND IN ANY SPECIFIC DRAWINGS IS UNCLASSIFIED AND CONFIDENTIAL PROPERTY OF FAIRBANKS SCALES & WEIGHING SYSTEMS. IT IS TO BE KEPT UNCLASSIFIED AND CONFIDENTIAL UNLESS OTHERWISE SPECIFIED. FAIRBANKS SCALES & WEIGHING SYSTEMS IS NOT RESPONSIBLE FOR ALTERATIONS TO THIS DOCUMENT AFTER ORIGINAL TRANSMISSION.

FAIRBANKS SCALES & WEIGHING SYSTEMS
11701
3-PLATE SERIAL #1000
2-PLATE SERIAL #1000
HOLE DIAMETERS #1/32"

SCALE: NTS
DRAWING NO: 11701
CHECKED: []
SHEET: 1 OF 1
DATE: 11/20/14
APPROVED: []
DRAWING NUMBER: D172280A-SP
REV: []