

**SECTION D-D**

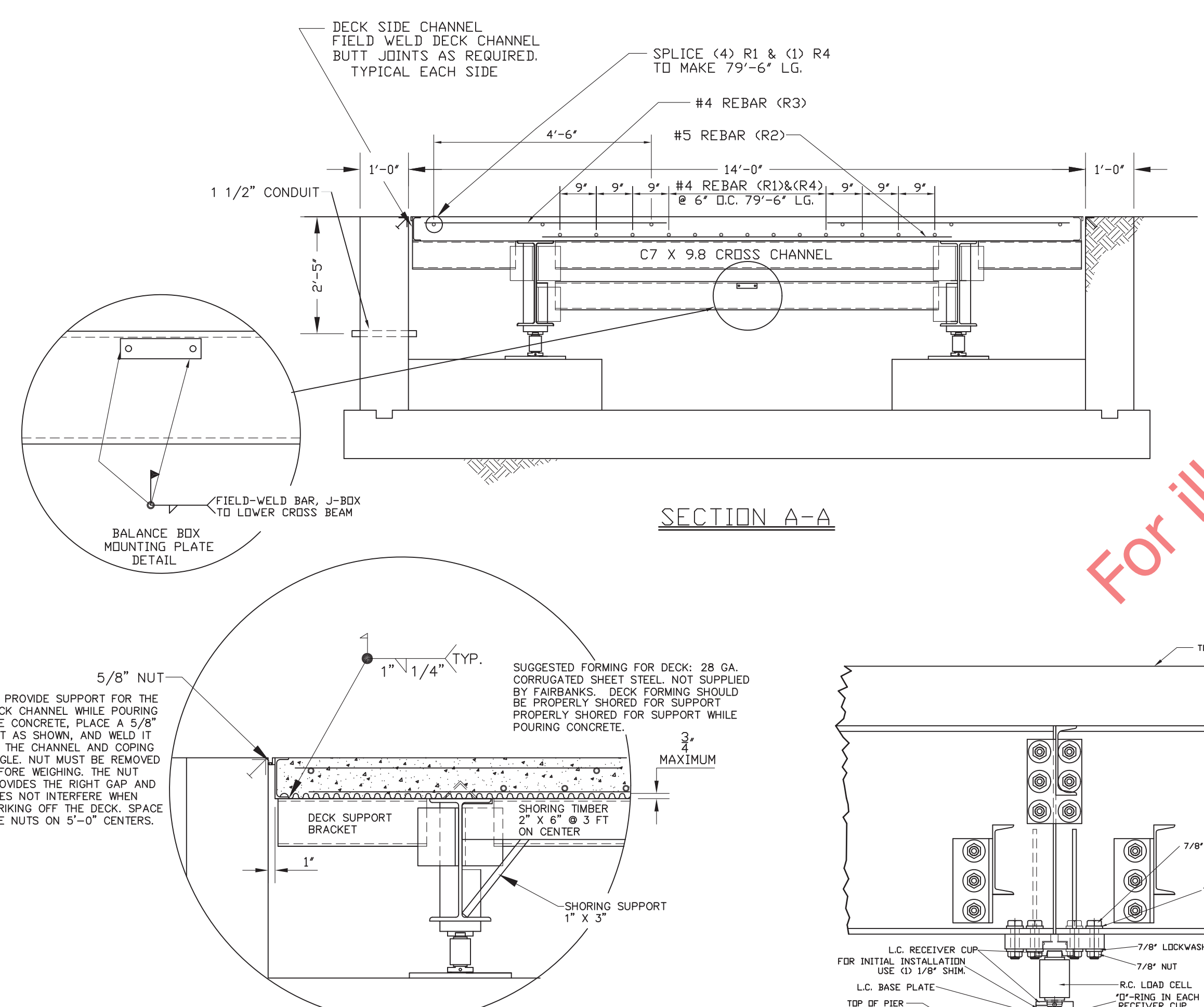

**SECTION A-A**

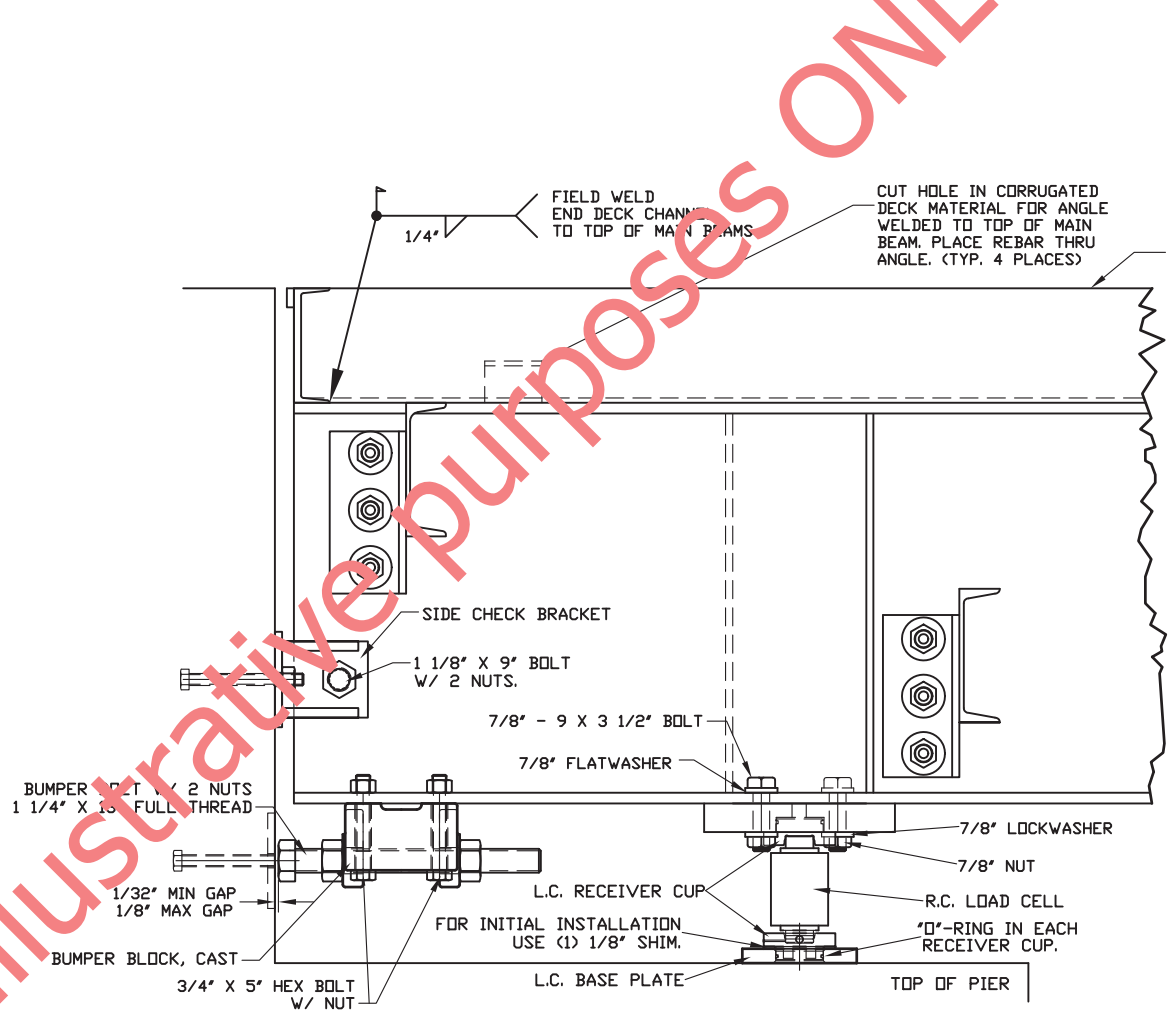

**VIEW C-C**

**LOAD CELL END ASSEMBLY DETAIL W/ END CHECKING DETAIL**

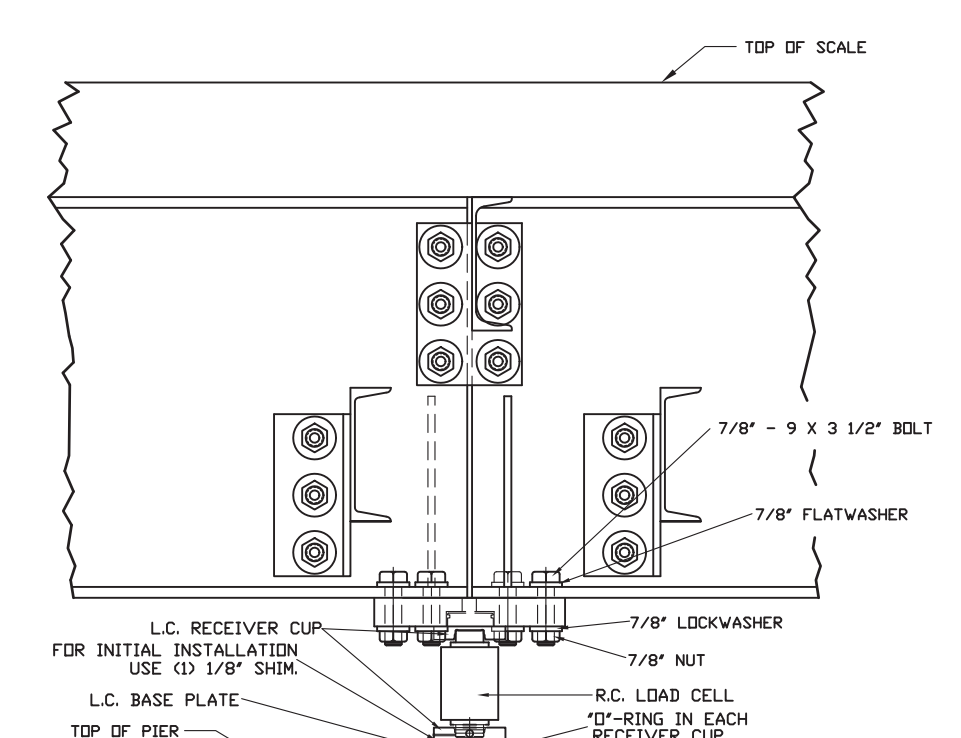

**VIEW B-B**

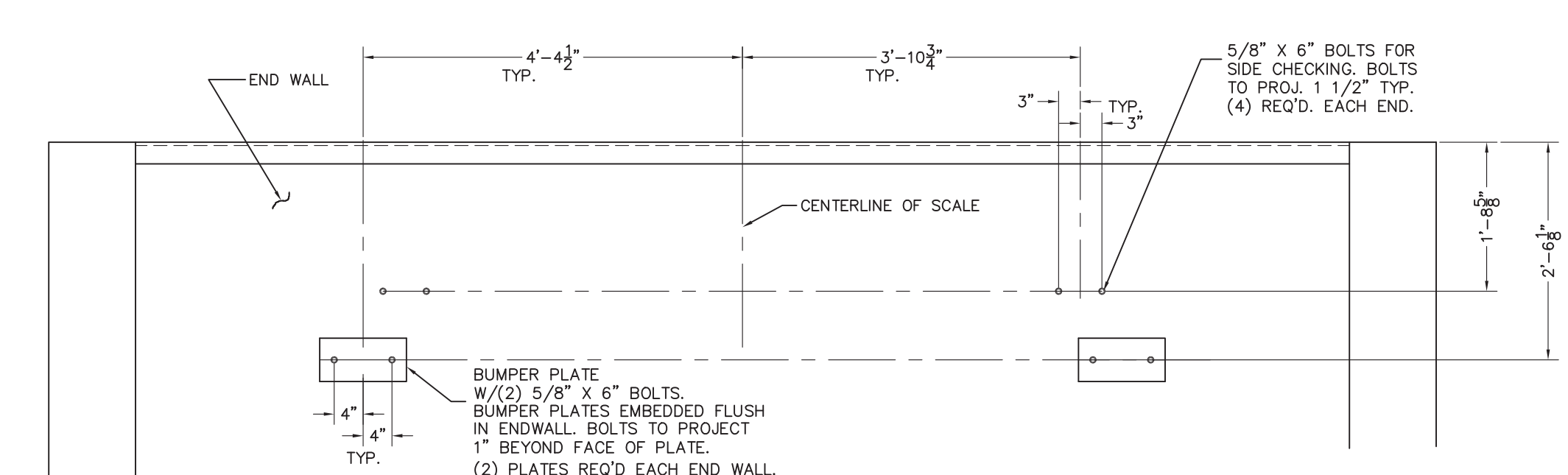

**END WALL CHECKING DETAIL**

**GENERAL NOTES:**

- EXCAVATION, FOUNDATION FORMS, FOUNDATION REBAR, AND ALL CONCRETE IS TO BE FURNISHED BY CONTRACTOR OR CUSTOMER OR AS CONTRACTED. REINFORCED FOUNDATION DRAWINGS SUITABLE FOR NORMAL INSTALLATION ARE AVAILABLE UPON REQUEST.
- THE PIT DIMENSIONS AS SHOWN ARE THE MINIMUM REQUIRED TO ACCOMMODATE THE SCALE. N.B.S. H44 REQUIREMENTS AND LOCAL WEIGHTS AND MEASURE REGULATIONS MAY SPECIFY ADDITIONAL INSTALLATION REQUIREMENTS. IN ORDER TO INSURE COMPLIANCE, CONSULT THE GOVERNING WEIGHTS AND MEASURE DEPARTMENT PRIOR TO INSTALLATION.
- TO COMPLY WITH SPECIFICATIONS OF N.I.S.T. H44, ANY ENDS OF A VEHICLE SCALE INSTALLED IN ONE LOCATION FOR A PERIOD OF SIX MONTHS OR MORE SHALL HAVE A STRAIGHT APPROACH AT LEAST AS WIDE AS THE PLATFORM AND AT LEAST ONE-HALF THE LENGTH OF THE PLATFORM. NOT LESS THAN 10 FEET ON ANY APPROACH ADJACENT TO THE PLATFORM SHALL BE CONSTRUCTED OF CONCRETE OR OTHER DURABLE MATERIAL TO INSURE THAT THIS PORTION REMAINS SMOOTH AND IS IN THE SAME PLANE AS THE PLATFORM. WHERE NECESSARY FOR DRAINAGE, THE REMAINING PORTION OF THE APPROACH MAY SLOPE SLIGHTLY.
- WORK FROM CENTERLINES WHEN ERECTING FORMS AND PLACING FOUNDATION BOLTS. PLACE BOLTS TO WITHIN ±1/8" OF POSITIONS INDICATED ON DRAWING. (BOLTS MUST BE PLACED WITHIN ±1/8" OF TOTAL DIMENSIONS FROM CENTERLINE OF SCALE.)
- ADEQUATE PROVISION MUST BE MADE FOR READY ACCESS TO THE PIT FOR INSPECTION OR MAINTENANCE. 24" DIA. MANHOLES ARE OPTIONALLY FURNISHED BY FAIRBANKS SCALES WHEN ORDERED. (SYM. NO. 5500B).
- APPROXIMATELY 20 CU. YD. OF CONCRETE IS REQUIRED FOR THE PLATFORM SLAB. USE f<sub>c</sub> = 4000 PSI CONCRETE.
- VEHICLES SHOULD ENTER AND EXIT SCALE FROM APPROACHES ONLY. ALL CROSS TRAFFIC SHOULD BE RESTRICTED.
- IT IS RECOMMENDED THAT THE WEIGHBRIDGE BE ASSEMBLED AND BLOCKED IN THE PIT BEFORE THE LOAD CELL ASSEMBLIES ARE ASSEMBLED AND INSTALLED.
- WHEN WELDING IN PIT OR ON WEIGHBRIDGE, LOAD CELLS MUST BE DISCONNECTED AND LEADS TAPED TO PREVENT THEM FROM TOUCHING EACH OTHER AND FROM GROUNDING.
- CAST-IN-PLACE ANCHOR BOLTS ARE NOT REQUIRED AT PIERS. BUT ARE REQUIRED IN THE END WALLS FOR CHECKING SYSTEM.
- TOPS OF ALL PIERS MARKED 'A' OR 'B' MUST BE SMOOTH FLAT & LEVEL, FOR LOAD CELL BASE PLATES TO BEAR PROPERLY.

**DECK REINFORCING (SUPPLIED BY FAIRBANKS)**

MARK	QTY.	SIZE	DESCRIPTION	WT.
R1	76	#4	20'-0"	1015
R2	147	#5	9'-0"	1389
R3	384	#4	5'-0"	1282
R4	19	#4	3'-6"	44
REBAR BUNDLE # 74145				

**DECK FORMING DETAIL**

LET BY	DATE	REVISION	<b>FAIRBANKS SCALES</b> Meridian, Mississippi	
PROJECT			80' X 14' SETTING PLAN 4-SECTION FULL ELECTRONIC w/ ROCKER COLUMN LOAD CELLS CAP. 75 TON 45K CLC	
DATE			3/1/00	NOTES
SCALE			N/A	PLT-2600RC-204
DRAWN BY			BT	SHEET 1 OF 1
CHECKED BY				<b>SETTING PLAN</b>
APPROVED BY				D91543-SP
MATERIAL				
FINISH				