

FAIRBANKS®

S C A L E S



FB2255 SERIES

KEYPAD INSTRUMENT FOR INDUSTRIAL SCALES

Versatile family of industrial instruments featuring a full numeric keypad. For use in any weighing application, from warehousing to general food processing or batching.



FB2255 SERIES

KEYPAD INSTRUMENT

Designed for a variety of use in dry and industrial applications.

• SYSTEM INTEGRATION • FOOD PROCESSING • BATCHING • FILLING • PROCESS CONTROL • STRESS TESTING



Bright green,

The FB2255 NEMA 4X stainless steel enclosure meets general food and other industrial washdown requirements.



Fairbanks' FB2255 IP69K Instrument has the highest ingress protection rating available for food processing, chemical or any application with heavy washdown needs.

Fairbanks' FB2255 Series Digital Instrument is a reliable choice for any industrial weighing application, from warehousing to general food processing. For batching and filling operations, system integration is easy — simply add a fieldbus accessory, such as PROFIBUS-DP, Ethernet/IP or DeviceNet. The FB2255 is also designed for convenient wireless operation with the aid of optional Bluetooth® wireless technology accessories.

Enclosure Types

- 304 Stainless Steel with IP69K rating.
- 304 Stainless Steel with NEMA 4X rating.
- 304 Stainless Steel Panel Mount - NEMA 4x.
- ABS Plastic (heat, impact and chemical resistant.)

Instrument Accessories

BATTERY POWER Five (5) "D" cell battery pack available for 304 Stainless NEMA 4X and ABS models.

Bluetooth® Enables wireless communications between the FB2255 and other serial devices, such as printers and PCs.

4-20 mA MODULE The 4-20 mA Module provides an analog input for PLCs, data loggers or other controllers.

FIELDBUS INTERFACES Fairbanks offers popular fieldbus interfaces, such as DeviceNet, PROFIBUS-DP, Ethernet/IP, or Ethernet/TCP to connect the FB2250 Instrument to PLCs/PCs.

The Bluetooth® word mark and logos are owned by the Bluetooth® SIG, Inc. and any use of such marks by Fairbanks Scales is under license. Other trademarks and trade names are those of their respective owners.

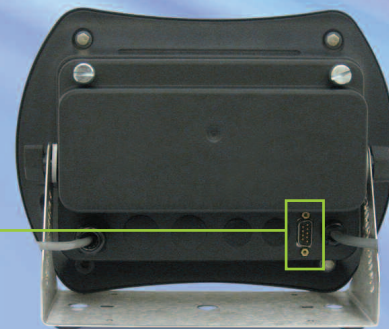

External DB9 output on ABS model



SS Battery Power Pack



ABS Battery Power Pack

Function Key Features

- ON/OFF** — One touch to power instrument up or down.
- ZERO** — Quickly zero off weight on the scale.
- PRINT** — Custom or standard print formats. This key also used to set time, date, and peak hold operations
- FULL NUMERIC KEYPAD** — For quick entry of Tare weights and numeric IDs.

...d to work with a
...weighing devices
...and washdown
...al applications.



FAIRBANKS[®] S C A L E S

FULL NUMERIC KEYPAD FOR QUICK ENTRY OF TARE WEIGHTS AND NUMERIC IDs.



FB2255 CUSTOMIZATION

FB2255 Series Instruments can be customized to meet your specific operational needs.

CUSTOM TICKET FORMAT

A distinct ticket format can be configured to allow the FB2255 to print information that meets your requirements.

CUSTOM UNITS

Many applications are unique and require a unique unit of measure. The FB2255 can accommodate these needs with this feature.

PROGRAMMABLE RS232 OUTPUT

The FB2255 RS232 Output can be configured to provide serial data in a customer specified format.

MULTI-POINT CALIBRATION

The FB2255's Multi-point Calibration function helps eliminate various linearity problems associated with platforms and tank applications.

ADVANCED FUNCTIONS

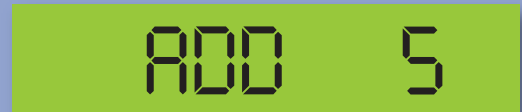

Easy-to-use piece counting function.

PIECE COUNTING

The FB2255 has a standard piece counting feature that turns any scale into a basic counting scale. This feature minimizes the time it takes to count parts. See sample display above.

ACCUMULATION

This feature allows users to continuously store individual weight reading and count/total the readings whenever desired. It also minimizes or eliminates the time-consuming task of manually tracking weight.

STRESS TESTING

Certain manufacturers are required to *stress test* products. The FB2255 is designed to easily accomplish this task. The unit captures the highest (or peak) weight reading and stores it. The printable reading remains stored until it is manually cleared or a higher peak weight is captured by the instrument.

Also known as Peak Hold, this feature provides stress test analysis that is required for ISO documentation.

- 1** PRINT
- 2** ZERO
- 3** ON/OFF
- 4** NET
- 5** TARE — Used to enter container weight.
- 6** ID ENTRY / SCROLL LEFT — Dual purpose key for left scrolling and numeric ID.
- 7** UNITS — Five selectable units (lb, kg, oz, g, lb-oz) and one programmable custom unit. Units key also used with piece count and accumulation features.
- 8** B/G / NET — One-push selection from Gross weight to Net weight. Also used during accumulation, piece count and sleep timer operations.

Stainless steel swivel bracket (included with all models)



FB2255 SERIES

KEYPAD INSTRUMENT FOR INDUSTRIAL SCALES

Weighing Solutions for the World Since 1830

Fairbanks.com

SPECIFICATIONS

Display	1.0" tall, 6-digit, green backlit LCD
Enclosure	Black ABS plastic, NEMA 1 rated; Stainless steel, NEMA 4X rated; Stainless steel, IP69K rated; Stainless steel, Panel mount
Pushbutton Keys	0-9, Decimal, Enter, ID/Left arrow, Right arrow, Menu, Zero, Print, Units, Tare, On/Off, B/G Net
Units	lb, kg, oz, g, lb-oz or custom
Capacity	Selectable 0 to 999,999
Graduation Size	0.0001 to 50
Load Cells	Up to eight 350 Ω cells or 16 1000 Ω cells
Power Requirements	Choice of AC or AC/DC (requires 5 "D" cell batteries)
Battery life (backlight enabled)	One 350 Ω load cell - 46 hrs, Four 350 Ω load cell - 26 hrs
Mounting	Desk / Wall mount stand (all models)
Output	COM 1 (standard): RS232, RS422, RS485; COM 2 (standard): RS232, RS422, RS485, 20 mA; External DB9 on ABS model
Remote switch inputs	Print, Tare, Gross/Net, Units, Zero
Accessories	Bluetooth [®] wireless technology, DeviceNet, 4-20 mA module, PROFIBUS-DP, Ethernet/IP, Ethernet/TCP, ControlNet
Approvals	NTEP CC# 09-023, MC #AM-5720, ETL

ABS PLASTIC ENCLOSURE

(Stainless steel bracket included — Battery power optional)

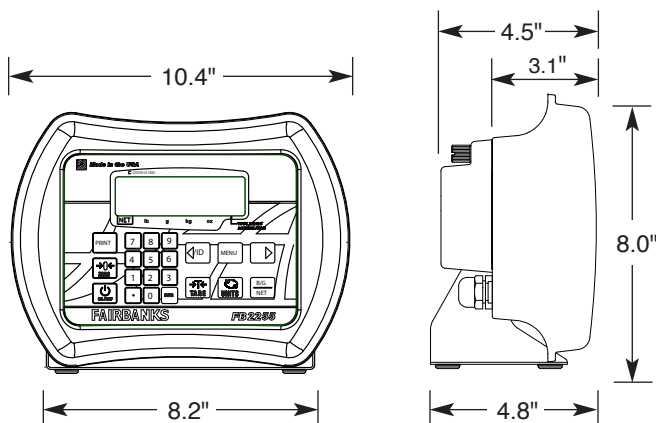

NEMA 4X STAINLESS STEEL ENCLOSURE

(Stainless steel bracket included — Battery power optional)

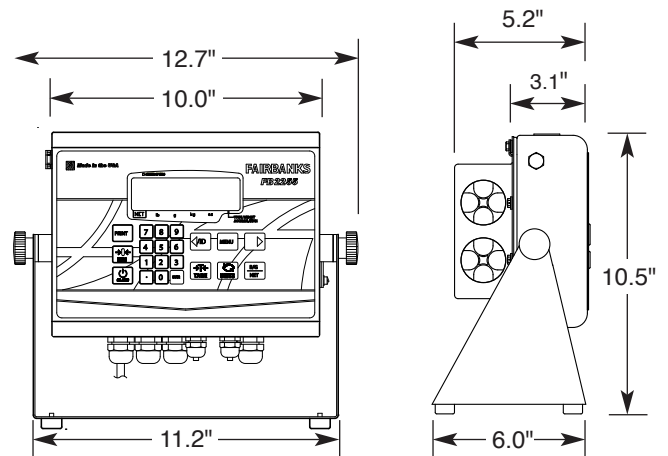

IP69K STAINLESS STEEL ENCLOSURE

(Stainless steel bracket included)

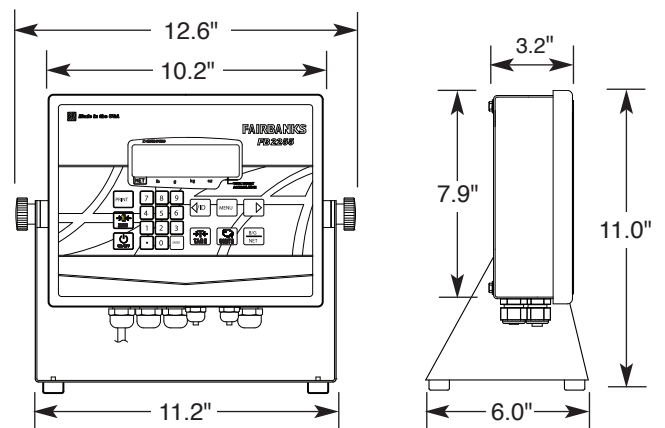

PANEL MOUNT STAINLESS STEEL ENCLOSURE

Front panel dimensions: height 11", width 13.2", depth 3.2"

Your Fairbanks Scales Authorized Representative is:

Call toll-free for the representative nearest you:

(800) 451-4107

Call between 8:00 a.m. – 5:00 p.m. Central Time

Corporate Offices: 821 Locust • Kansas City, MO 64106 • (816) 471-0231

Internet Address: <http://www.Fairbanks.com>

