



1600 Series LED Remote Display

1601, 1605, 1605RF, 1605T,
1605T-RF, and 777 Traffic Light



Amendment Record
1600 Series LED Remote Display
DOCUMENT 51157

Manufactured by Fairbanks Scales Inc.
821 Locust
Kansas City, Missouri 64106

Revision 1	05/2007	Created and released manual.
Revision 2	07/2007	Included 1601 drawings and information. Updated 1605 specifications.
Revision 3	08/2007	Corrected drawings and verbiage.
Revision 4	01/2008	Updated specifications and steps.
Revision 5	04/2009	Software Enhancements, added INTEL feature, Updated wiring charts 4169, 4170 & 51157-3.
Revision 6	10/2009	Updated parts list.
Revision 7	08/2010	Added wiring and parts for 1605T and 777.
Revision 8	09/2011	Added newest model that includes RF Remote Modem, and updated PCB Card. Updated manual format and verbiage.
Revision 9	08/2014	Added 1605T-RF information and factory default load procedure. Corrected 1601 parts list.
Revision 10	11/2014	Added wiring instructions for ACC777 to FB2550.
Revision 11	03/2018	Added Field Connections chart, Added ACC 777 AC Power Connections diagram
Revision 12	09/2018	Updated Parts List
Revision 13	08/2019	Updated Parts List

Disclaimer

Every effort has been made to provide complete and accurate information in this manual. However, although this manual may include a specifically identified warranty notice for the product, Fairbanks Scales makes no representations or warranties with respect to the contents of this manual, and reserves the right to make changes to this manual without notice when and as improvements are made.

Fairbanks Scales shall not be liable for any loss, damage, cost of repairs, incidental or consequential damages of any kind, whether or not based on express or implied warranty, contract, negligence, or strict liability arising in connection with the design, development, installation, or use of the scale.

© Copyright 2007-2019

This document contains proprietary information protected by copyright. All rights are reserved; no part of this manual may be reproduced, copied, translated, or transmitted in any form or by any means without prior written permission of the manufacturer.

Table of Contents

SECTION 1: GENERAL INFORMATION	6
1.1. Introduction	6
1.2. Specifications	7
SECTION 2: COMPANY SERVICE INFORMATION.....	9
2.1. General Service Policy	9
2.1.1. Conferring with Our Client	9
2.2. Getting Started	10
2.2.1. Pre-Installation Checklist	10
2.2.2. Unpacking.....	10
2.3. Users' Responsibilities.....	11
SECTION 3: INSTALLATION.....	12
3.1. Installing the 1605 Remote Display	12
3.1.1. Introduction	12
3.1.2. Installation.....	12
3.2. Wiring the Remote Display.....	13
3.2.1. Wiring Configuration, Remote Display.....	13
3.2.2. Wiring ACC 777 LED Traffic Light (29001) to FB2550.....	14
3.2.3. ACC 777 AC Power Connections.....	15
3.3. Installing the 1605RF/1605T-RF Remote Display	15
3.3.1. Introduction	15
3.3.2. Installing the REMOTE DISPLAY RF Antenna	15
3.3.3. Installing the INDICATOR RF Antenna	16
3.3.4. Powering Up for RF Unit Test.....	17
3.4. Wiring Configuration, Traffic Light.....	18
3.5. Installing the Optional Temperature Probe.....	18
3.6. Installing Multiple Displays	19
3.6.1. 20mA Configuration	19
3.6.2. RS232 Configuration	19
3.6.3. RS485 Configuration	20
3.7. Starting up the Remote Display	20
SECTION 4: PROGRAMMING.....	21
4.1. Accessing the Control Buttons.....	21
4.1.1. 1601 Remote Display	21
4.1.2. 1605 Remote Display	21
4.2. Programming with the Buttons.....	22
4.2.1. PCB Switch Functions	22
4.3. Communications Programming.....	24
4.3.1. Automatic Programming Mode	24
4.3.2. Adjusting the Digit Placement.....	25
4.3.3. Display Output Default Setups	25
4.3.4. Manual Programming Mode	26
SECTION 5: SERVICE & MAINTENANCE	34
5.1. Receive / Warning	34
5.2. RF Transmitter/Receiver Will Not Transmit	34
5.3. VOLTAGE Test	34



5.4. Factory Default Settings 35

SECTION 6: PARTS..... 36

6.1. Model 1601 (27720) 36

6.1.1. Model 1601 Parts List..... 36

6.1.2. Model 1601 Parts Diagram..... 38

6.2. Model 1605 (26575) 40

6.2.1. Model 1605 Parts List..... 40

6.2.2. Model 1605 Parts Diagram..... 42

6.3. Model 1605rf (30981) 45

6.3.1. Model 1605RF Parts List..... 45

6.3.2. Model 1605RF Parts Diagram, Exterior..... 47

6.3.3. Model 1605RF Parts Diagram, Interior..... 48

6.4. Model 1605T (29000) 49

6.4.1. Model 1605T Parts List..... 49

6.4.2. Model 1605T Parts Diagram, Exterior..... 51

6.4.3. Model 1605T Parts Diagram, Interior..... 52

6.5. Model 1605T-RF (31934) 53

6.5.1. Model 1605T-RF Parts List..... 53

6.5.2. Model 1605T-RF Parts Diagram, Exterior..... 55

6.5.3. Model 1605T-RF Parts Diagram, Interior..... 56

6.6. Model 777 (29001) 57

6.6.1. Model 777 Parts List..... 57

6.6.2. Model 777 Parts Diagram..... 59

APPENDIX I: FB350 PROGRAMMING..... 62

APPENDIX II: 2500 SERIES PROGRAMMING..... 63

APPENDIX III: CPU ASSEMBLY – PREVIOUS VS. CURRENT MODELS 64

A. 1601 (30400) –CPU Assy Wiring Chart (1-1/2" Display)..... 65

B. 1605 and 1605RF (30400) –CPU Assy Wiring Chart (5" Display)..... 65

C. 1605T and 1605T-RF (30400) –CPU Assembly Wiring Chart (5" Display)..... 65

D. 1605 (30400) –CPU Assembly Wiring Chart (1-1/2" Display)..... 66

APPENDIX IV: 20MA CODES 67

APPENDIX V: DATA INPUT..... 69

A. Remote Display Input..... 69



Section 1: General Information

1.1. INTRODUCTION

The **Fairbanks 1600 series** is an intelligent LED Remote Display.

- The bright red LED display is easily viewed from distances of **up to 75 feet** for the **1601**, and up to **300 feet** for the **1605**.
 - The unit is equipped with an **Adjustable Intensity Control**.
- The **1600 Series Remote Displays** are housed in a weather-tight enclosure for inside or outside use.
 - The **Reflect Mode** displays the weight information correctly in a mirror.
 - A hooded shield eliminates glare and protects it from debris and weather.
 - There are no moving parts within the Remote Display.
 - The unit can detect the data communication protocols of nearly every scale manufacturer's instruments with a **Programmable Learning Mode**.
- The **1605RF Remote Display** is installed with a **Radio Frequency (RF) Controlled Modem** and comes with a **Stand-alone RF Modem** for the transmitting peripheral device.
 - The system allows for wireless communication between the remote display and a weighing instrument or computer.
- The **1605T Traffic Light** can be configured to work with dry contact relay closure or with serial data from instruments such as FB3000. Refer to the appropriate instrument manual for details.
- The **777 Stop Light** is a separate stand-alone unit that interfaces with a Remote Display and the Indicator for a simultaneous **GO/STOP** message.

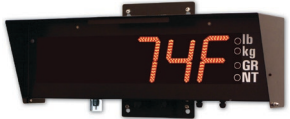
1.2. SPECIFICATIONS

Display Types	<ul style="list-style-type: none"> • 1601 Remote Display (27720) <ul style="list-style-type: none"> — One-and-a-half inch (1.5") High Intensity LED Display 
	<ul style="list-style-type: none"> • 1605 Remote Display (26575) <ul style="list-style-type: none"> — Five inch (5") High Intensity LED Display — Six (6) digits with seven (7) segments — Includes decimal and colon 
	<ul style="list-style-type: none"> • 1605RF Remote Display with RF Interface (31850) <ul style="list-style-type: none"> — Comes with a factory-installed internal RF Transmitter/Receiver, and a stand-alone RF Transmitter/Receiver. — The system allows for wireless communication between the remote display and a weighing instrument or computer.
	<ul style="list-style-type: none"> • 1605T Display with Stop Light (29000) <ul style="list-style-type: none"> — Green circle for GO. — Five inch (5") red "X" for STOP. 
	<ul style="list-style-type: none"> • 1605T-RF Display with Stop Light and RF Interface (31934) <ul style="list-style-type: none"> — Green circle for GO. — Five inch (5") red "X" for STOP. — Comes with a factory-installed internal RF Transmitter/Receiver, and a stand-alone RF Transmitter/Receiver. — The system allows for wireless communication between the remote display and a weighing instrument or computer.
	<ul style="list-style-type: none"> • 777 Stop Light (29001) <ul style="list-style-type: none"> — Green circle for GO. — Five inch (5") red "X" for STOP. 
Additional Display Features	<ul style="list-style-type: none"> — Time — Date — Temperature (<i>optional</i>) — Lb. or Kg displays — GR or NT displays
Communication Interface	<ul style="list-style-type: none"> • RS232, 50 feet maximum • RS485, 4000 feet max • 20mA Current Loop, 1000 feet maximum • Active or Passive • Dry contact relay closure for traffic lights
Frequency Range	902-928 MHz
Program Setup	Automatic or Manual



Viewing Distance	<ul style="list-style-type: none">• 1601 – Up to 75 feet• 1605, 1605RF, 1605T, and 1605T-RF – Up to 300 feet
Enclosure	1601 – NEMA 4X 1605, 1605RF, 1605T, 1605T-RF, and 777 – NEMA 3
Temperature Range	-29C to 49C / -20F to 120F
Power	117 VAC, 1A Max

Section 2: Company Service Information

2.1. GENERAL SERVICE POLICY

Prior to installation, ***always*** verify that the equipment satisfies the customer's requirements as supplied, and as described in this manual.



2.1.1. *Conferring with Our Client*

- The lead tech must be prepared to recommend the arrangement of components which provide the most efficient layout, utilizing the equipment to the best possible advantage.
- The warranty policy must be explained and reviewed with the customer.

If the equipment cannot satisfy the application and the application cannot be modified to meet the design parameters of the equipment, **the installation should *NOT* be attempted.**

It is **the customer/operator's responsibility** to ensure the equipment provided by Fairbanks is operated within the parameters of the equipment's specifications and protected from accidental or malicious damage.

Before the installation is considered complete, the equipment is to be programmed to meet or exceed any applicable weights and measures requirements.

2.2. GETTING STARTED

2.2.1. Pre-Installation Checklist

The following points should be checked and discussed with the **Area Sales Manager and/or customer**, if necessary, before the technician goes to the site and installs the equipment.

- ✓ Check the customer's application to make certain it is within the capabilities and design parameters of the equipment.
- ✓ If the installation process might disrupt normal business operations, tell the customer and ask that they make ample arrangements.
- ✓ Is properly-grounded power available at the installation location?
- ✓ Be sure that the equipment operator(s) are available for training.
- ✓ The Service Technician must thoroughly review the installation procedures.
- ✓ The service technician reviews the recommended setup with the Area Sales Manager or Area Service Manager, and together they identify all necessary variations to satisfy the customer's particular application.



2.2.2. Unpacking

Follow these guidelines when unpacking all equipment:

- Check in all components and accessories according to the customer's order.
- Remove all components from their packing material, checking against the invoice that they are accounted for and not damaged.
 - Advise the shipper immediately, if damage has occurred.
 - Order any parts necessary to replace those which have been damaged.
 - Keep the shipping container and packing material for future use.
 - Check the packing list.
- Collect all necessary installation manuals for the equipment and accessories.
- Open the equipment and perform an inspection, making certain that all hardware, electrical connections and printed circuit assemblies are secure.
- Do not reinstall the cover if the final installation is to be performed after the pre-installation checkout.
- Keep equipment away from magnetic material or other instruments which use magnets in their design.



2.2.3. Safety

Follow these safety precautions during operation:

- Be careful lifting and moving the remote terminal when installing or repairing it.
- Ensure that the supporting structure for the remote display suits its weight in advance of installation.



2.3. USERS' RESPONSIBILITIES

All electronic and mechanical calibrations and or adjustments required for making this equipment perform to accuracy and operational specifications are considered to be part of the installation.

- They are included in the installation charge.
- Only those charges which are incurred as a result of the equipment's inability to be adjusted or calibrated to performance specifications may be charged to warranty.

The equipment consists of printed circuit assemblies which must be handled using ESD handling procedures, and must be replaced as units.

- Replacement of individual components is not allowed.
- The assemblies must be properly packaged in ESD protective material and returned intact for replacement credit per normal procedures.

Absolutely no physical, electrical or program modifications are to be made to this equipment, other than selection of standard options and accessories.

- Electrical connections other than those specified may not be performed, and **physical alterations to the installed unit** (holes, etc.) **are not allowed.**



Section 3: Installation

3.1. INSTALLING THE 1605 REMOTE DISPLAY

3.1.1. Introduction

The **1600 Series Display** comes with a mounting bracket on the back of the enclosure.

- The AC power cord exits the enclosure through a watertight gland in the bottom of the case.
- One additional small watertight gland on the left side of the unit is provided for future expansion.
- Two additional watertight glands are provided for the RS232 or 20mA loop cable from the indicator.
- The **Display** can be wall mounted or, using **ACC 1400**, mounted to a pole.
- The **777** can be pole mounted using **Slip-fitter Accessory**, or wall mounted using **Wall Mount Bracket**.

3.1.2. Installation

1. Mount the display in its proper designated location.
2. **Remove the four screws** holding the Access Panel and Liquid-tight Glands on the **bottom of the display enclosure**.
3. Bring the **Communications Cable** from the Indicator through the Water-tight Gland in the plate from the bottom of the display.
 - Provide enough cable inside the display to reach **TB1** on the **PC Board**.
4. Dress and tin the ends of the **Communications Cable** wires.
5. Remove the **Plug-in Connector** from TB1.
6. Wire the plug as shown in the selected wiring configuration.
7. Insert the **Plug** into **TB1**.
8. **Reinstall the four screws** on the bottom of the display enclosure.

3.2. WIRING THE REMOTE DISPLAY

The setup of the remote display consists of the following steps:

1. Wire the display to the indicator.
2. Wire the displays together, if there is more than one.
 - The display can be wired for **20mA Active, 20mA Passive, RS485** or **RS232**.

3.2.1. Wiring Configuration, Remote Display

A. Indicators with PASSIVE 20MA OUTPUT (polarity sensitive).

INDICATOR	INTERFACE ASSEMBLY	TB1 on CPU
20mA (+)	(+) 15 VDC	(1)
	GND	(2) Jumper to (8)
	RS232 Rx	(3)
	RS232 Tx	(4)
	RS485A	(5)
	RS485B	(6)
20mA (-)	C-Loop (+)	(7)
	C-Loop (-)	(8) Jumper to (2)

B. Indicators with **ACTIVE 20MA OUTPUT**

INDICATOR	INTERFACE ASSEMBLY	TB1 on CPU
	(+) 15 VDC	(1)
	GND	(2)
	RS232 Rx	(3)
	RS232 Tx	(4)
		(5)
		(6)
20mA (+)	C-Loop (+)	(7)
20mA (-)	C-Loop (-)	(8)

3.2.1. Wiring Configuration, Remote Display, continued

C. Indicators with RS232 Output

INDICATOR	INTERFACE ASSEMBLY	TB1 on CPU
	(+) 15 VDC	(1)
GND	GND	(2)
Tx	RS232 Rx	(3)
	RS232 Tx	(4)
		(5)
		(6)
	C-Loop (+)	(7)
	C-Loop (-)	(8)

D. Indicators with RS485 Output

INDICATOR	INTERFACE ASSEMBLY	TB1 on CPU
	(+) 15 VDC	(1)
GND	GND	(2)
	RS232 Rx	(3)
	RS232 Tx	(4)
RS485A	RS485A	(5)
RS485B	RS485B	(6)
	C-Loop (+)	(7)
	C-Loop (-)	(8)

3.2.2. Wiring ACC 777 LED Traffic Light (29001) to FB2550

A. Wire the ACC 777 LED Traffic Light a

- The maximum number of installed ACC 777s is two (2).
- ACC 777 (29700) is a sub-assembly component within the Traffic Light (29001).
- Requires Relay Interface Accessory (30920) to be installed in the FB2550.

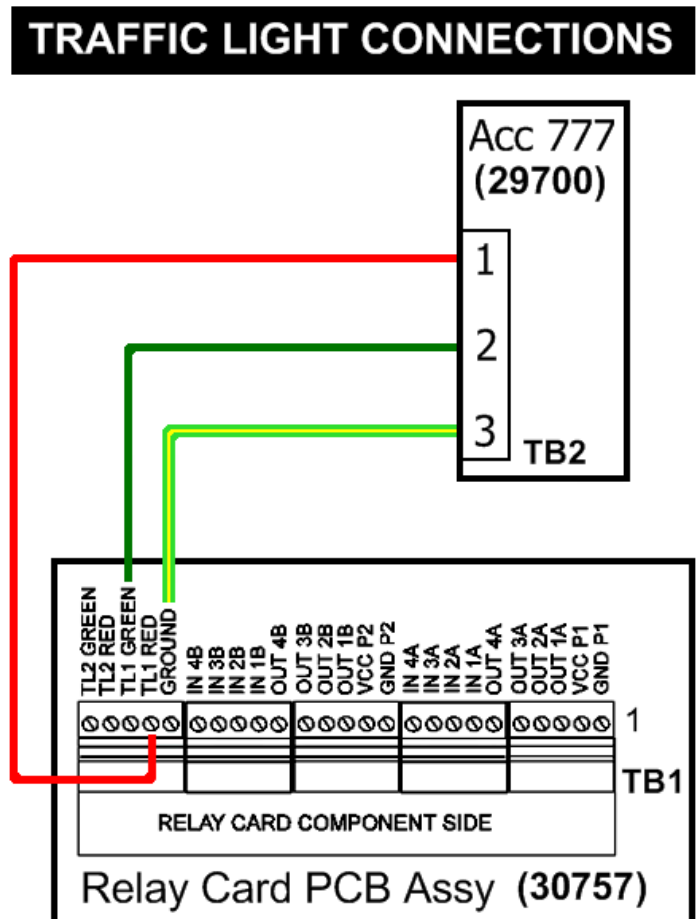

3.2.3. ACC 777 AC Power Connections

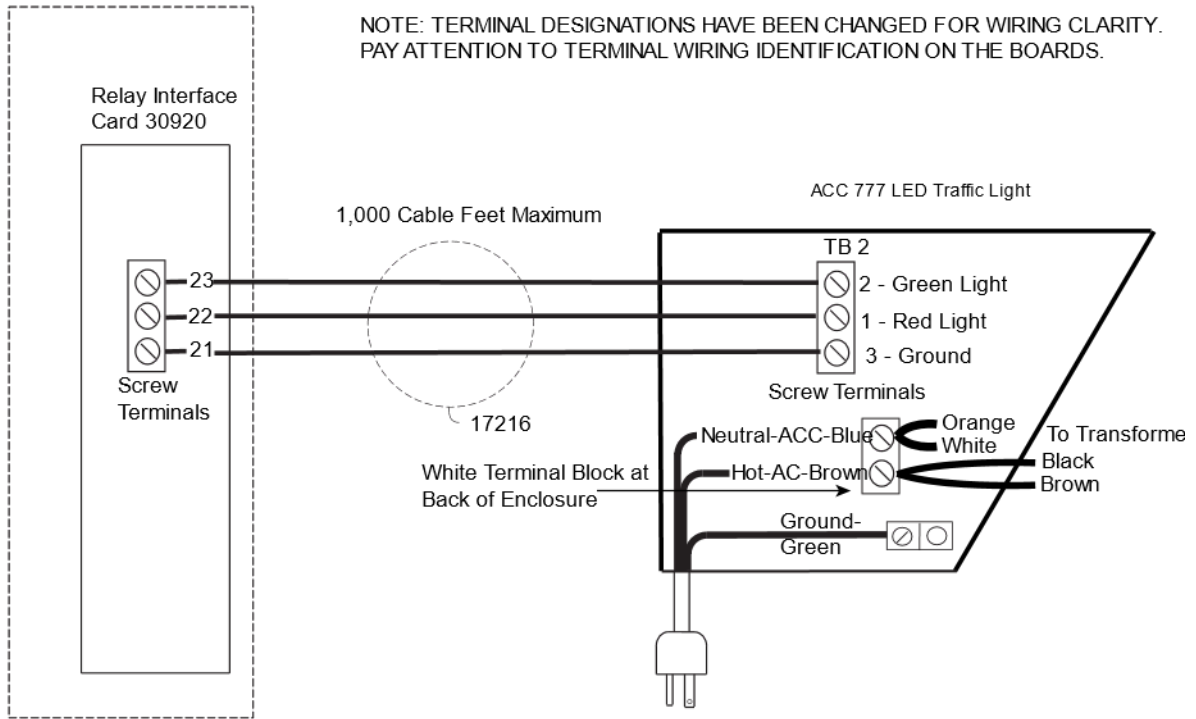

3.3. INSTALLING THE 1605RF/1605T-RF REMOTE DISPLAY

3.3.1. Introduction

The RF Transmitter/Receiver allows the 1605 (p/n 30981) to display the weightment wirelessly.

— In ideal conditions, the RF Signal transmits up to one thousand feet (1000’).

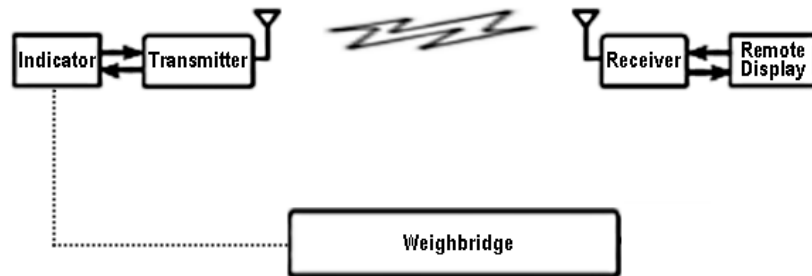

3.3.2. Installing the **REMOTE DISPLAY** RF Antenna

1. Mount the 1605RF Remote Display in a similar manner as the model 1605.
 - The Remote Display RF Antenna components are internal, and are factory preinstalled and wired..

NOTE: For complete installation details, see **SECTION 3.1.**

2. Remove the **four (4) cover screws** on the RF Transmit/Receiver inside 1605 Remote Display.
3. Set the **switch positions** on both RF Transmit/Receiver to those like the image below.

- **Switch One** is the only one in the **ON** position. **All others** are **OFF**.

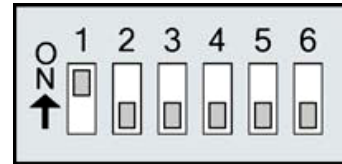

4. Program the **communication settings** on both the Indicator and the Remote Display RF Transmitter/Receivers to match the parameters shown below.

Baud Rate	9600
Data Bits	8
Stop Bits	1
Parity	None

NOTE: Use these settings *ONLY* with the **1605RF/1605T-RF Remote Display**

5. Replace the **cover**, fastening it with the **screws**.
6. Plug in the **DB9 cable** from the RF Antenna to the Remote Display.

3.3.3. Installing the **INDICATOR RF Antenna**

1. Set the **switch positions** on both RF Transmit/Receivers to those in **Step 3** above.
2. Determine the best Indicator RF Antenna position.
 - This will be in a direct line-of-sight to the Remote Display.
 - Follow the distance guidelines shown below:

Indoor/Urban Range	Up to 300 ft.
Outdoor RF Line-of-sight Range	Up to 1000 ft.

3. Position the Antenna in a secure, permanent and protected place.
 - If the signal is blocked between the two antennas by passing vehicles or other obstructions, the transmitted data will be incomplete or corrupted.
4. Hold up the Antenna in its proper position on the wall, then mark the drill holes with a pencil.
5. Drill the appropriate size holes for mounting the external RF Antenna.
6. If needed, insert the wall anchor.
7. Secure the Antenna into position with the four screws.
8. Plug in the **DB9 cable** from the RF Antenna to the Indicator.



3.3.4. Powering Up for RF Unit Test

1. **Apply power** to the Remote Display and to the Indicator.
2. Move the External RF Transmitter/Receiver Power **Switch to ON** (up).

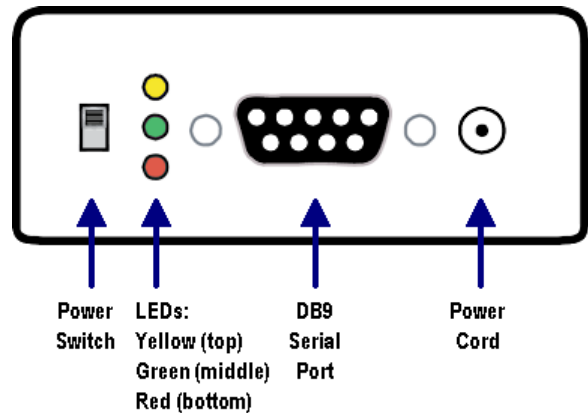

The LEDs on the External RF Transmitter/Receiver indicates the following:

Yellow	Serial Data Out (to host)
Green	Serial Data In (from host)
Red	Power/TX Indicator

1. The red light is on when the unit is powered.
2. The green LED pulses on/off briefly during RF transmission.

3.4. WIRING CONFIGURATION, TRAFFIC LIGHT

The **1605T and 1605T-RF** is shipped with the traffic light connected to the CPU PCB. It operates in this mode when used with a **Fairbanks FB3000 Instrument** with the proper output string in the **Kernel**.

A. Wiring when connected to **ACC 702T Manual Switch (30006)**

TB2 on Traffic Light Module (29700)	TB1 ACC 702T
1	3
2	2
3	1

B. Wiring when connected to **ACC 703 Relay Box (13170)**

TB2 on Traffic Light Module (29700)	TB1 ACC 703
1	3
2	2
3	1

C. Wiring when connected to non-specified relay or switch

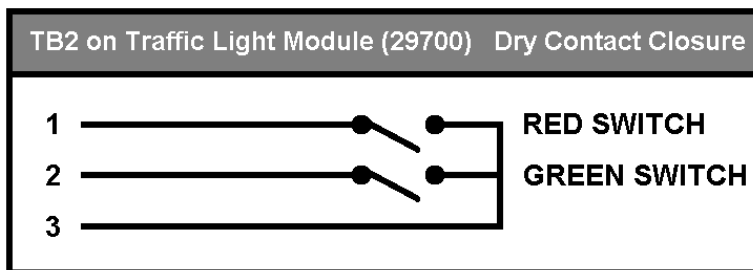

3.5. INSTALLING THE OPTIONAL TEMPERATURE PROBE

1. Insert the optional **Temperature Probe** into the open **Watertight Gland**, tightening the threads until it is snug.
2. Connect the two (2) **Temperature Probe wires** to TB2.
 - Connections are not polarity sensitive (+ and -), so wires can attach to either terminal.

3.6. INSTALLING MULTIPLE DISPLAYS

Multiple Displays are Daisy-Chained together using the **Passive 20mA Retransmission**.

3.6.1. 20mA Configuration

Additional displays are wired the same as **Display 2** and **Display 3**.

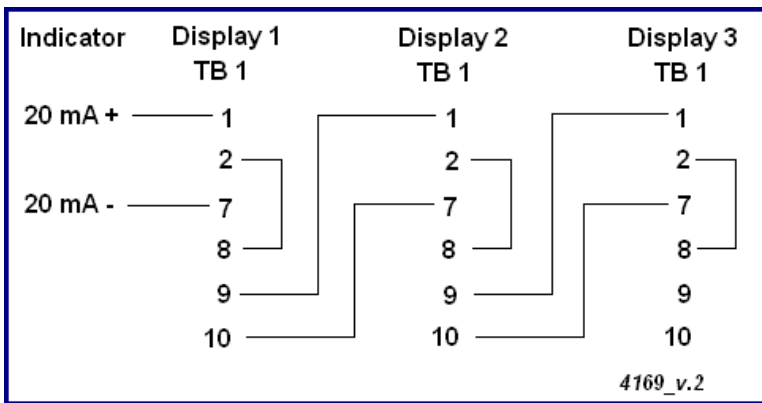

3.6.2. RS232 Configuration

Additional displays are wired the same as **Display 2** and **Display 3**.

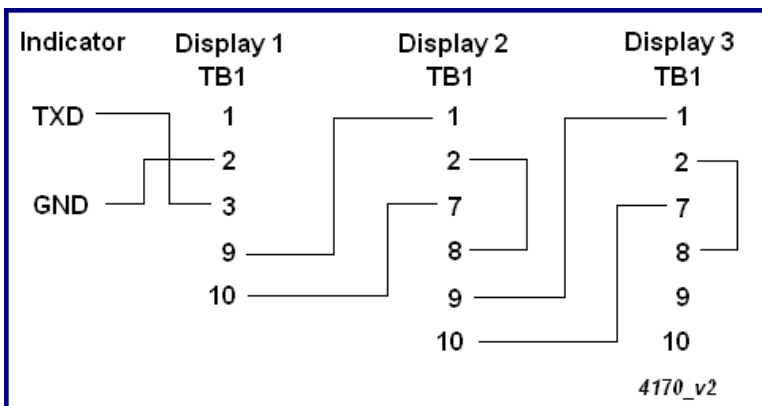

3.6.3. RS485 Configuration

When using the **RS485 Configuration**, displays are Daisy-chained together.

Indicator	Display 1 TB1	Display 2 TB1	Display 3 TB1
	1	1	1
GROUND	2	2	2
RS485A	5	5	5
RS485B	6	6	6
	9	9	9
	10	10	10

51157-3_v2

3.7. STARTING UP THE REMOTE DISPLAY

1. Turn on the Remote Display.
 - The Remote Display first displays the **Program** and **Revision Number**, then it proceeds through a counting sequence.
 - The intensity of the light changes.
 - The display blanks momentarily, then shows the weight value sent by the indicator.
 - The warm-up sequences are complete, and the Remote Display is ready.



Section 4: Programming

4.1. ACCESSING THE CONTROL BUTTONS

Programming the Remote Display to perform its daily functions requires pressing the six (6) control buttons on the PCB, located inside the unit.

4.1.1. 1601 Remote Display

1. Remove the **two (2) screws** on the **front** of the Display Panel.
2. Carefully drop down the display front to access the Control Buttons



4.1.2. 1605 Remote Display

1. Remove the **four (4) screws** on the **bottom**, opening the access panel.

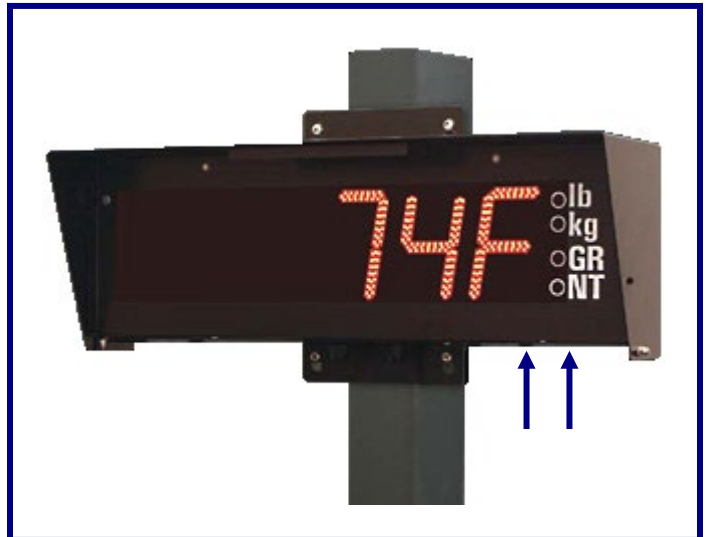

4.2. PROGRAMMING WITH THE BUTTONS

- There are **six switches** located on the PC Board used to program the display.
- **These switches are accessed either through the small door on the under side of the display enclosure or through the front panel.**
- Remove the four fastening screw to open the front panel, then carefully open the display enclosure.

4.2.1. PCB Switch Functions

SW1 RESET

Resets the microprocessor and allows the display to go through the **Warm-up Sequence**.

SW2 LEFT

Shifts the displayed data one place to the **LEFT**.

- This switch will also **ADVANCE** to the next program step.

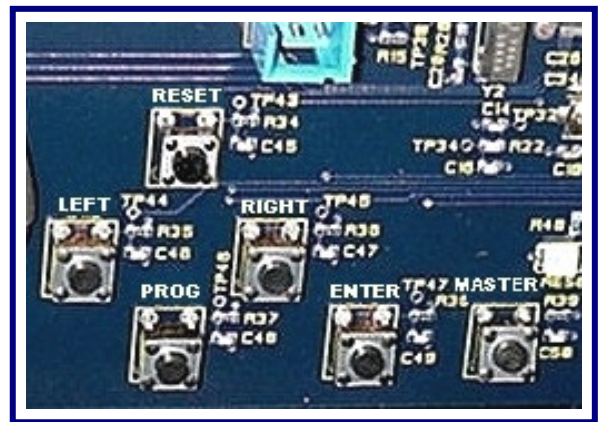

SW3 RIGHT

Shifts the displayed data one place to the **RIGHT**.

- This switch will also **BACKUP** to the previous program step.

SW4 PROG

Allows access for manual programming or auto programming.

SW5 ENTER

Accepts the displayed choice during the programming operation.

SW6 MASTER RESET

Issues a **Hardware Reset**.

- Currently the same as pressing the **RESET** button.

See the following page for the diagram and accompanying picture.

4.2.1. PCB Switch Functions, Continued

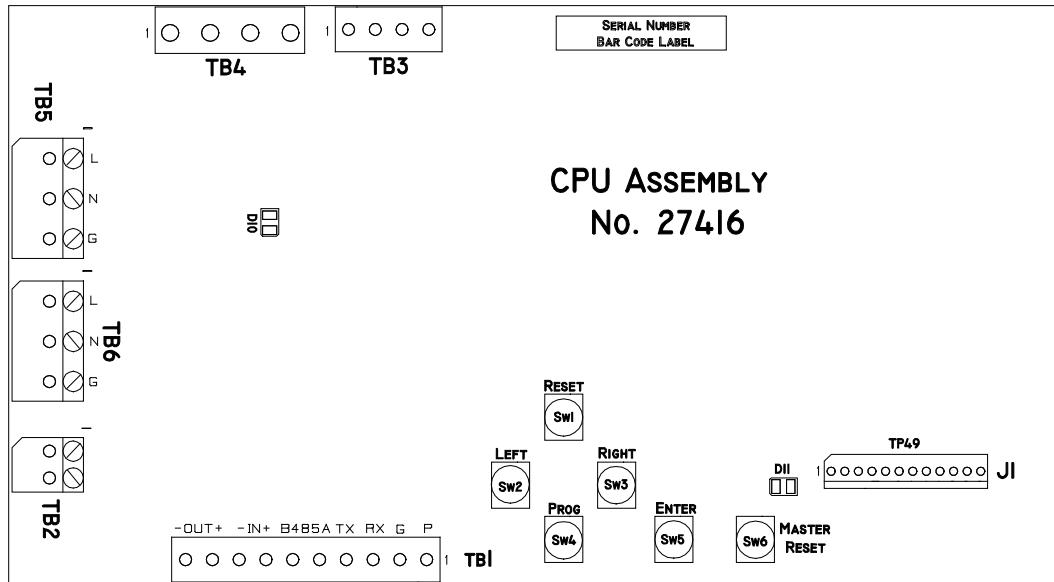

The drawing above shows the formatting buttons and the pertinent I/O plugs. Pictured below is the actual CPU Assembly.

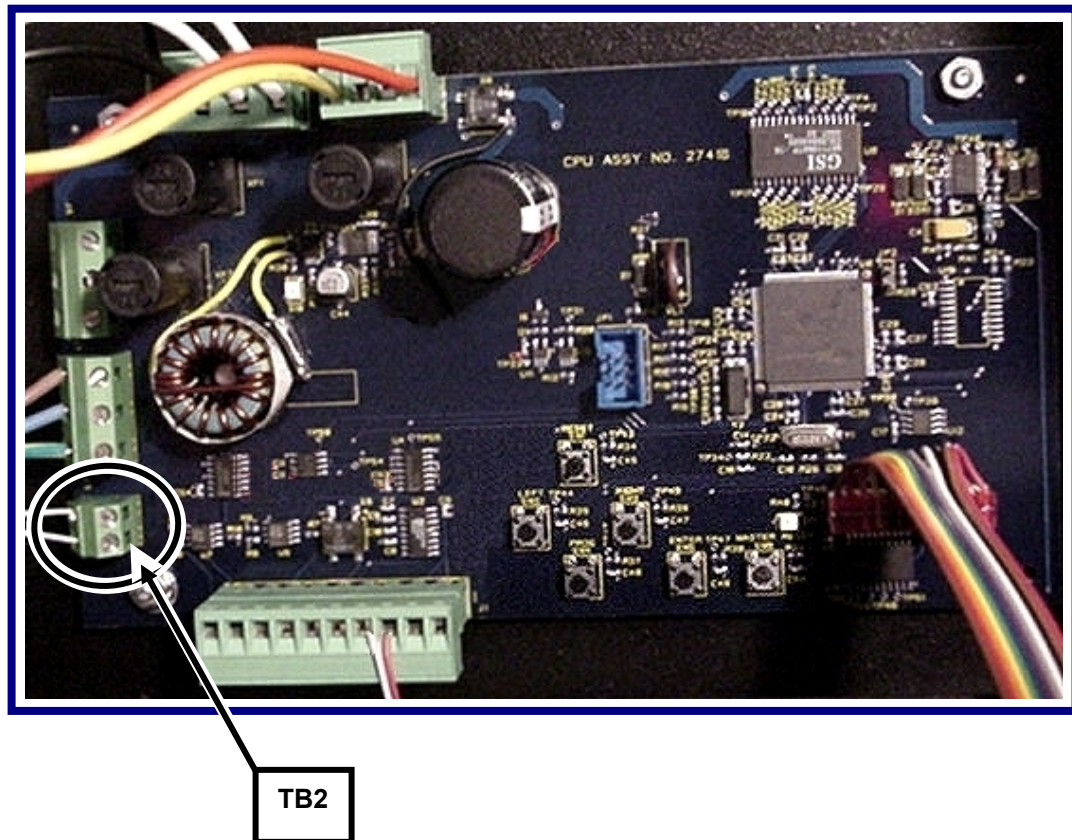

NOTE: Previous version PCB Card drawing is shown in [Appendix III](#).

4.3. Communications Programming

The **Communications Programming** performs either *automatically* or *manually*.

- When using the **Automatic Mode**, the display automatically tries to determine the communications protocol sent by the indicator during the warm-up sequence.
- Once the protocol is determined, it is stored in memory for future use.
- Protocol parameters include the **Baud Rate**, **Data Bits**, and **Parity**.
- ***It is recommended to use the automatic method first.***
 - If this does not succeed, use the manual method.

4.3.1. Automatic Programming Mode

The instrument interfaced to the **1600 Series Remote Display** must have following to perform properly.

- The proper port must be configured.
- The cable must be connected to the appropriate port.
- For the **Automatic Programming Mode** to work properly, the unit must be placed in the **Continuous Output Mode**.
 1. Press the **RESET** switch to start the **Warm-up Sequence**.
 2. During the sequence, press down and hold the **PROG** switch for **three (3) seconds**, and then release.
 - The display continues through the warm-up sequence.
 - The display will start at **9 8 2** and count down searching for a communications match. All other programming is unaffected.

When the Automatic Programming is complete and successful, the current weight is displayed.

4.3.2. Adjusting the Digit Placement

If **Step 4** is successful and weight information is being received, use the **LEFT** and **RIGHT** switches to move the displayed digits to their appropriate location.

NOTE: If **INTELL** is set to **ON** the left and right buttons are inactive.

1. Press the **LEFT** or **RIGHT** switch to shift the displayed data.

If the display shows:



Press:



S3 (Right)



S3 (Right)



Or press:



S1 (Left)



S1 (Left)



50885-1

4.3.3. Display Output Default Setups

The Remote Display Output has the following default setups:

- **2400 Baud**
- **Seven (7) Data bits**
- **Odd parity**

4.3.4. Manual Programming Mode

1. Power-up the display.
2. After the warm-up sequence is complete, press and hold the **PROG** switch for **three (3) seconds**, then release.
 - To advance or back up through the program steps, **press the LEFT or RIGHT switch.**
 - **To view the stored value, press the ENTER switch.**

NOTE: At any time through the formatting process, press the **PROG** switch to exit to **DONE** then press **ENTER** to save and exit.

3. Press the **LEFT** or **ENTER** switch.
 - **The word BAUD displays.**
4. Press the **ENTER** switch.
 - The current Baud Rate Setting displays (*i.e.* 2400).
5. Use the **LEFT** or **RIGHT** switches to toggle through the available **Baud Rate Settings**.

— 300	— 600	— 1200	
— 2400	— 4800	— 9600	
— 19,200	— 38,400	— 57,600	— 115,200
6. Press the **ENTER** switch to select the appropriate setting.
7. When the abbreviation **CHAR** displays, press the **ENTER** switch.
 - Either a seven (**7**) or an eight (**8**) displays for the current **Data Bits Setting**.
8. Use the **LEFT** or **RIGHT** switches to toggle and select the correct setting.
9. Press the **ENTER** switch to confirm the setting.
 - The word **PARITY** displays.
10. Press the **ENTER** switch and the display will show the current parity setting.
11. Use the **LEFT** or **RIGHT** switches to toggle through the three choices.

— None	— Even	— Odd
--------	--------	-------
12. With the appropriate choice displayed, press the **ENTER** switch.

4.3.4. Manual Programming Mode, Continued

13. The abbreviation **ID** displays, signifying “*Identification.*”
 - The **ID Filter** sorts data from a **Data String** from the Instrument.
 - The **ID Filter** then displays that Data only.
14. Press the **ENTER** switch
 - **ALPH X** displays, where **X** is the current setting.
15. Press the **LEFT** or **RIGHT** switches to toggle through choices.
 - **Y = Yes — N = No.**
 - *If **Y** is selected, the display uses Alpha Characters for the ID.*
 - *If **N** is selected, the display uses a Numeric ID.*
 - *See tables on the next page.*
16. Press the **ENTER** switch.
 - The current **ID Setting** displays.
 - The **RIGHT** switch increments the **right digit**.
 - The **LEFT** switch increments the **left digit**.
17. Press the **ENTER** switch.
18. With the appropriate choices displayed, press the **ENTER** switch.

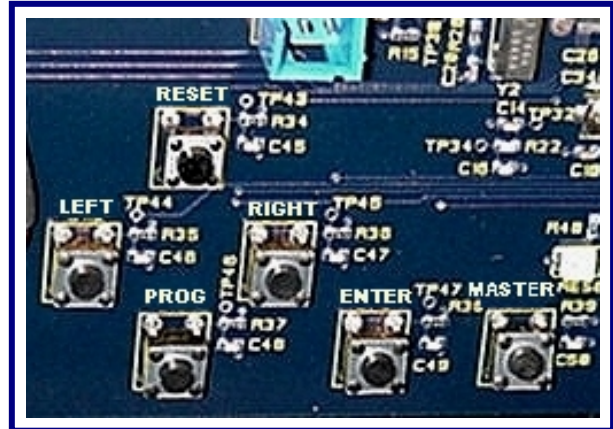

Numeric ID Formats	
CODE	DATA DISPLAYED
40	Lb. Gross
41	Lb. Net
42	Lb. Tare
43	Kg. Gross
44	Kg. Net
45	Kg. Tare
00	Display all data received

NOTE: *The letters **M** and **W** are not displayed.*

- The word **INTELL** displays
19. Press the **ENTER** switch.
 - The current setting displays either **ON** to automatically justify weight data, or **OFF** to manually justify (**LEFT** and **RIGHT** buttons active).
 - Pressing the **LEFT** or **RIGHT** switches toggles the choices.

4.3.4. Manual Programming Mode, Continued

20. Press **ENTER**

— The word **REFLECT** displays.

21. Press the **ENTER** switch.

— The current setting displays either a **YES** for **Reflect, Mirror Viewing** or **NO** for **Normal Viewing**.

— The **Reflect, Mirror Viewing Option** presents the digits in reverse for viewing through the truck mirrors.

22. Pressing the **LEFT** or **RIGHT** switches toggles the choices.

23. Press **ENTER**.

— The word **IDLE** displays.

24. Press the **ENTER** switch.

— The **Current Idle Time-Out Value** (*in seconds*) displays.

— This blanks the weight value *when no valid data is received*.

25. Use the **LEFT** or **RIGHT** switches to select a value between **5-15 seconds**.

26. With the appropriate selection displayed, press the **ENTER** switch.

— The word **INT** displays.

27. Press the **ENTER** switch, and the current setting displays (**20, 40, 60, 80, 100, or AUTO**).

28. Press the **LEFT/RIGHT** switch to **increase/decrease** the digits' value.

— **AUTO INTENSITY** automatically adjusts the brightness of the display dependent upon ambient light conditions. This setting will max at 80 in bright sunlight.

— *The numeric value represents the percentage of brightness. The larger the number, the brighter the display.*

29. With the desired setting displayed, press the **ENTER** switch.

— The word **COLON** displays.

4.3.4. Manual Programming Mode, Continued

30. Press the **ENTER** switch, and the current **COLON** setting displays.
31. Select **NO**.
 - Only select **YES** if time output from 2500 series indicator is selected.

NOTE: *If selected incorrectly, display errors may occur.*

32. Press the **ENTER** switch.
 - The word **TIME** displays.
33. Press the **ENTER** switch and the current setting displays.
34. Press the **LEFT** or **RIGHT** switches to select either **12hr**, **24hr**, or **NO**.

Select one of the following:

- 35A. Select the Twelve (**12hr**) hour or the Twenty-four (**24hr**) hour setting.
 - Press the **ENTER** switch and the **current time** setting displays.
 - Use the **LEFT** or **RIGHT** switches to change the **hour**.
 - Press the **ENTER** switch when the hour is correct.
 - Use the **LEFT** or **RIGHT** switches to change the **minute**.
 - Press the **ENTER** switch when the minute is correct.
 - Press the **ENTER** switch.
- 35B. Or, select **NO** and follow the steps on the next page.
 - The word **DATE** displays.
 - Press the **ENTER** switch and the **DATE SETTING** displays.

NOTE: *Time output from 2500 Series Indicator will override internal time setting.*

4.3.4. Manual Programming Mode, Continued

36. Press the **LEFT** or **RIGHT** switches to select either **YES** or **NO**.
37. Press the **ENTER** switch.
 - If **YES**, the **CURRENT MONTH** displays.
 - Use the **LEFT** or **RIGHT** switches to change the **MONTH**.
 - Press the **ENTER** switch when the month is correct.
 - Use the **LEFT** or **RIGHT** switches to change the **DAY**.
 - Press the **ENTER** switch when the day is correct.
 - Use the **LEFT** or **RIGHT** switches to change the **YEAR**.
 - Press the **ENTER** switch when the year is correct.
 - The word **TEMP** displays to set the option of whether the temperature displays or not.
38. Use the **LEFT** or **RIGHT** switches to select **YES** for displaying the temperature, or **NO** for not displaying the temperature.
 - If **YES** is selected, then the *optional* temperature sensor must be installed.
39. Press the **ENTER** switch.
40. If **YES** Use the **LEFT** or **RIGHT** switches to select either **C** (Celsius) or **F** (Fahrenheit) temperature to be displayed.
41. Press the **ENTER** switch.
 - The word **ANNUN** displays.
 - **ANNUN** refers to **Annunciator**, which displays whether the scale is programmed for the following:
 - Pounds or Kilograms (lb/kg).
 - Gross Weight or Net Weight (GR/NT).
 - Automatic.
42. Press the **ENTER** switch and the current **Annunciator** setting displays.
43. Press the **LEFT** or **RIGHT** switches to select **YES**, **NO**, **AUTO** or **SCALE**.



4.3.4. Manual Programming Mode, Continued

Select one of the following:

44A. If **YES** is selected, the word **MODE** displays.

- a. Press the **ENTER** switch and the word **UNIT** displays.
- b. Press the **ENTER** switch, and the current measure of **UNITS** displays.
- c. Press the **LEFT** or **RIGHT** switches to select **KG** or **LB**.
- d. Press the **ENTER** switch and the word **TYPE** displays.
- e. Press the **ENTER** switch and the current setting displays.
- f. Press the **LEFT** or **RIGHT** switches to select **TR1**, **TR2**, **GR**, or **NET**.
 - **TR1** mode displays **both** the **Gross** and **Net Weights**.
 - **TR2** mode displays **neither** the **Gross** nor **Net Weights**.
- g. Observe the annunciator lights for the setting value.

44B. Selecting **NO** turns off the **Annunciator Display**.

44C. Selecting **AUTO** works only with **ID** set to **“00”**, and changes according to the **ID CODE** sent from the instrument.

44D. Selecting **SCALE** offers a choice of scales **one (1) thru eight (8)** when connected to an FB3000 indicator.

- a. Press the **LEFT** or **RIGHT** switches to select the **correct scale number**.

MULTISCALE ID FORMATS								
No 1	No 2	No 3	No 4	No 5	No 6	No 7	No 8	
CODE SENT FROM INDICATOR FB3000/FB2550								DATA DISPLAYED
40	46	52	58	64	70	76	82	Lb. Gross
41	47	53	59	65	71	77	83	Lb. Net
42	48	54	60	66	72	78	84	Lb. Tare
43	49	55	61	67	73	79	85	Kg. Gross
44	50	56	62	68	74	80	86	Kg. Net
45	51	57	63	69	75	81	87	Kg. Tare

4.3.4. Manual Programming Mode, Continued

45. Press the **ENTER** switch and the word **TEST** displays.
46. Press the **ENTER** switch to display **DIGIT**.

Select one of the following:

- 47a. To test **LED digits**, press the **ENTER** switch and the *left-most digit* turns on.
 - a. Use the **LEFT** or **RIGHT** switches to display any of the six digits.
 - b. Press the **ENTER** switch to return to the **TEST** selections.

- 47b. To test the display intensity, press the **LEFT** or **RIGHT** switches to display **A2D**.
 - a. Press the **ENTER** switch.
 - b. Counts from the **A2D** for the light sensor are displayed.
 - c. To check **A2D operation**, increase and decrease light intensity on the annunciator panel between the **KG** and **GR** labels.
 - d. Press the **ENTER** switch to return to the **TEST** selections.

- 47c. To revert to the factory default settings, press the **LEFT** or **RIGHT** switches to display **DEFAULT**.
 - a. Press the **ENTER** switch and **RUSURE** displays.
 - b. Press the **ENTER** switch to set defaults, or press the **LEFT** or **RIGHT** switches to return to the **TEST** selections.
 - c. The word **DEFAULT** displays, and the unit returns to the **TEST** selections.

48. Press the **PROG** switch to exit the **TEST** selections.
 - **DONE** displays.

49. Press the **ENTER** switch to be finished with the setup, or use the **LEFT** or **RIGHT** switches to cycle back through the program steps.
 - The word **STORE** displays.

4.3.4. Manual Programming Mode, Continued

50. Press the **PROG** switch to toggle the display between **STORE** and **CANCEL**.

- The **STORE** selection keeps the program changes.
- The **CANCEL** selection *does not* store the changes made.

51. Press the **ENTER** switch.

- The word **SAVED** flashes if **STORE** is selected, saving the changes, and then returning to the **Normal Mode**.

IMPORTANT NOTE: *All the changes are lost if **CANCEL** is selected, and then the display returns to the **Normal Mode**.*

Section 5: Service & Maintenance

5.1. Receive / Warning

There is a **green LED Display** located by the switches on the PC Board that **verifies the data flow in the system.**

The **LED blinks on and off continuously**, indicating it has a “**live connection.**”

- This indicates the data is being received.
- When the display is **not receiving data** from the indicator, it becomes "blank".
- If the display **receives invalid data** from the indicator, it becomes "blank".

Invalid data is data without a string terminator.

Proper string terminators are: **CR** (carriage return), **LF** (line feed), **ETX** (end of text), or **EOT** (end of transmission).

5.2. RF TRANSMITTER/RECEIVER WILL NOT TRANSMIT

If the Indicator does not detect the RF Transmitter/Receiver, the problem may be in the **Power Adapter.**

- The red power LED on the RF Transmitter/Receiver will be on.
- When a message is transmitted to the Remote Display, the yellow and green lights do not flicker simultaneously.

The solution is to replace the **RF Transmitter/Receiver Power Adapter.**

- The adapter output is **9VDC at 500mA.**

5.3. VOLTAGE TEST

Unloaded voltage measurement for the 20 mA loop.

Model	TB1-1 to TB1-2
1605/ 1605T/ 1605RF/ 1605T-RF	23 VDC
1601	14.5 VDC

5.4. FACTORY DEFAULT SETTINGS

Load the Factory Default settings by holding the left and right buttons down while pressing the Master Reset button or applying power. **"FACT"** will display.

Press the **Master Reset** button again or reset the power at this time.

This process will load the Factory Default settings into the remote display's configuration programming.

Section 6: Parts

6.1. MODEL 1601 (27720)

6.1.1. Model 1601 Parts List

ITEM	PART NO.	QTY	DESCRIPTION
1	27723	1	ENCLOSURE ASSEMBLY
2	27722	1	FRONT PANEL ASSEMBLY
3	27719	1	WINDOW
5	27714	1	BRACKET
6	30400*	1	CPU PCB ASSEMBLY
7	28040	1	LED DISPLAY PCB ASSEMBLY
9			
10	15435	1	POWER CORD ASSY
11			
12	27106	1	CABLE ASSY
13	27109	1	CABLE ASSY, GROUND
14	17545	2	CONNECTOR, LIQUIDTIGHT .75
15	15651	2	O-RING - FOR .75
16	17534	1	CONNECTOR, LIQUIDTIGHT .75
17	12342	1	O-RING - FOR .75
18	12609	2	ROD, NYLON
19			
20			
21	27727	1	OVERLAY, LEGEND 1601
22	27432C	1	BLOCK, TERMINAL PLUG 10 POS XTB1
23			
25			
26	27715	1	GASKET, TOP
27	27716	1	GASKET, BOTTOM

* Previous CPU PCB Assembly model number is **27416**.

6.1.1. Model 1601 Parts List, Continued

ITEM	PART NO.	QTY	DESCRIPTION
28	27717	2	Gasket, Side
29			
30			
31	28229	1	Transformer
32	17521	1	Plug, Terminal 4 POS .295 C-C
33	27434C	1	Plug, Terminal 4 POS .197 C-C
34	14225	1	Plug, Hole .50 Dia.
35	11073	1	Screw-cap-hex Hd. 10-24 X 2.00
36	11075	2	Screw-cap-hex Hd. 10-32 X .50
37	11076	2	Screw-cap-hex Hd. 10-32 X .75
38	10310	6	Washer-Flat No. 6
39	11191	13	Washer-Lock-Ext. Tooth No. 6
40	11192	1	Washer-Flat No. 10
41	11495	6	Washer-Plain (Nylon) No. 10
42			
43	11092	1	Washer-Lock-Med-Spring No. 10
44	11099	3	Nut-Hex 10-24
45	11102	13	Nut-Hex 6-32
46	15716	2	Nut, Thread-Lock Acorn 10-32
47	15745	2	Knob
48	12621	2	Washer, Retainer
49	12103	4	Foot
50	11134	4	Screw-Mach-Ph-Phil 8-32 x .31
51	17507	20	Spacer, Hex 6-32 Thds. X .19 Long
52	11226	1	Nameplate
53	27726	1	Nameplate-Data For Tag on Sh 1
54			
55	13486	1	Connector Kit, DB9 ACC 334
*	27428C	2	Fuse 2A F1, F2
*	27429C	1	Fuse 6.3A F3

* *Parts not shown in diagram.*

6.1.2. Model 1601 Parts Diagram

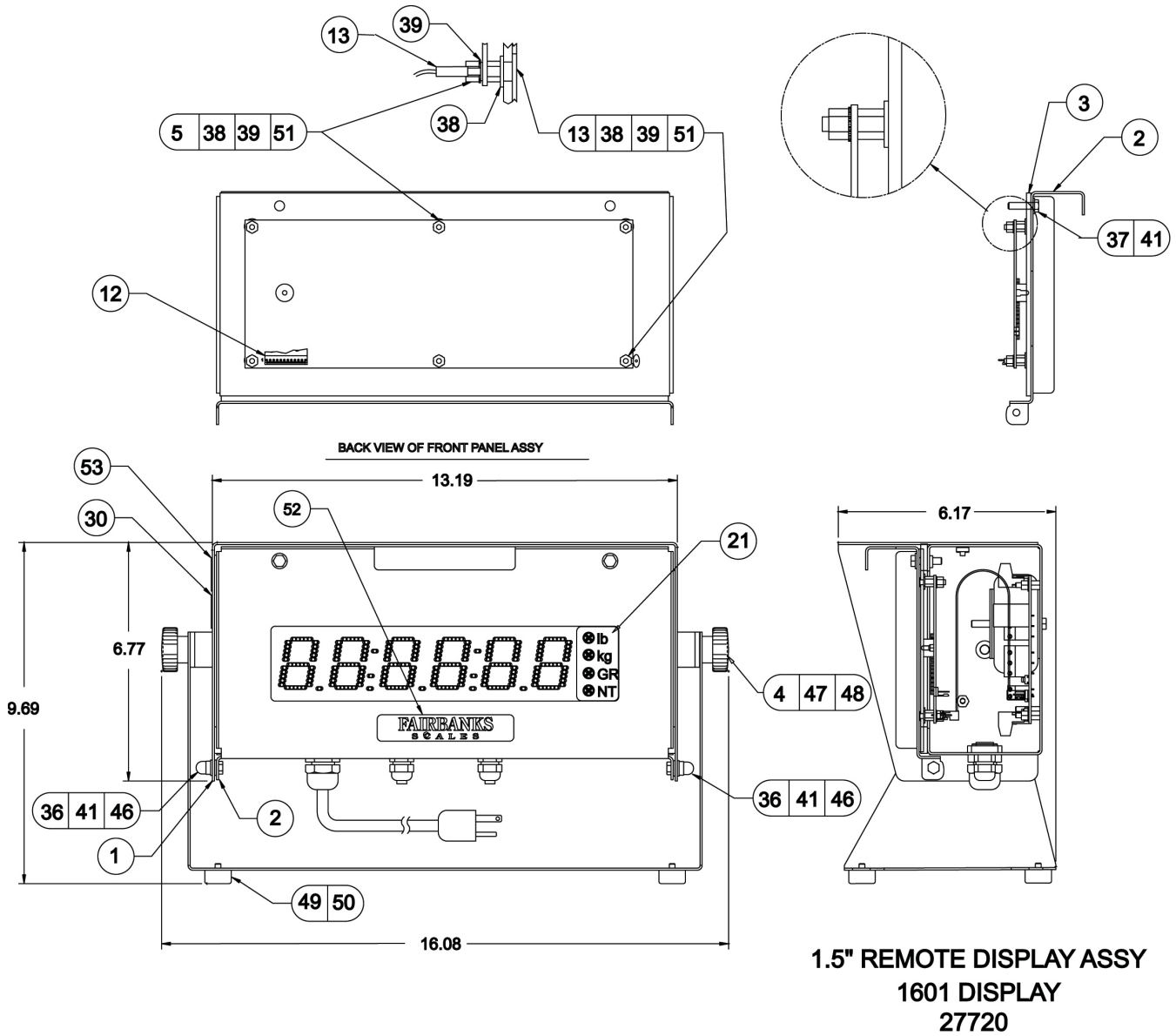

6.1.2. Model 1601 Parts Diagram, Continued

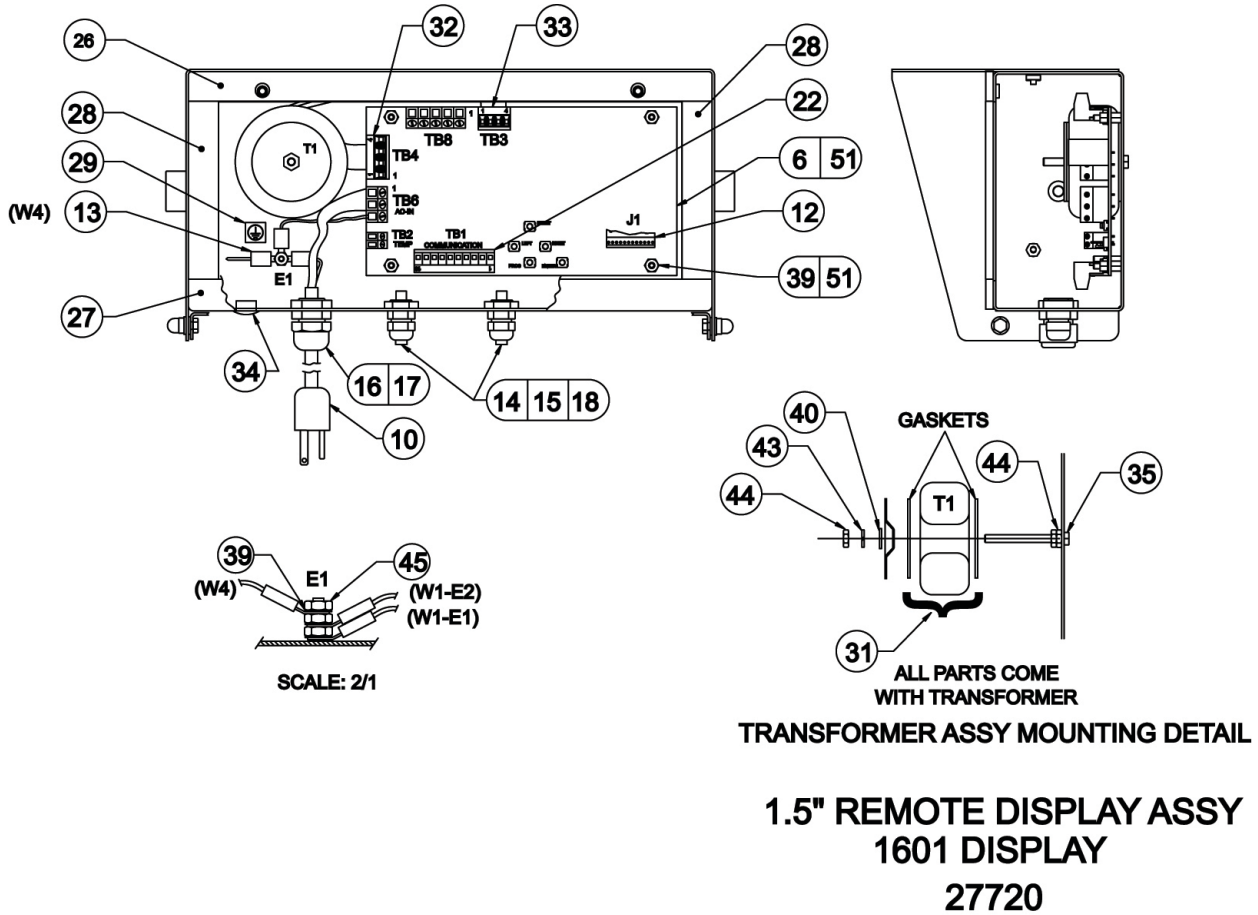

6.2. MODEL 1605 (26575)

6.2.1. Model 1605 Parts List

ITEM	PART NO.	QTY	DESCRIPTION
1	26571	1	Enclosure Assembly
2	26568	1	Front Panel Assembly
3	26569	1	Window
5	27212	2	LED Display PCB Assembly
6	30400*	1	CPU PCB Assembly
7	27531	1	Annunciator PCB Assembly
8	27721	1	Foam Spacer
10	15435	1	Power Cord Assembly
11	27105	2	Cable Assembly
12	27106	1	Cable Assembly
13	27109	1	Ground Cable Assembly
14	17545	2	Liquid Tight Connector 0.50
15	15651	2	O-Ring For 0.50
16	17534	2	Liquid Tight Connector 0.75
17	12342	2	O-Ring For 0.75
18	12609	3	Nylon Rod
20	26570	1	Access Door
21	27107	1	Legend Overlay
22	27432C	1	Terminal Block Plug 10 Position
24	11660	4	Hex Spacer 6-32 THDS x 0.25 Long
26	26572	1	Top Gasket
27	16573	1	Bottom Gasket
28	16574	2	Side Gasket
30	26563	1	Transformer Mounting Plate
31	27656	1	Transformer
32	17521	1	Terminal Plug 4-Pos 0.295 C-C
33	27434C	1	Terminal Plug 4-Pos 0.197 C-C
34	14225	1	Hole Plug 0.50 Dia.
36	11075	6	Screw-Cap-Hex Hd. 1032 x 0.50
37	11076	4	Screw-Cap-Hex Hd. 1032 x 0.75

* Previous CPU PCB Assembly model number is **27416**.

6.2.1. Model 1605 Parts List, Continued

ITEM	PART NO.	QTY	DESCRIPTION
38	10310	14	Washer-Flat
39	11191	25	Washer-Lock-Ext. Tooth No. 6
41	11495	12	Washer-Plain (Nylon) No. 10
42	25715	8	Washer-Retaining No. 10
44	17597	14	Spacer 6-32 x 0.19
45	11102	25	Hex Nut 6-32
46	15716	2	Thread-Lock Acorn Nut 10-32
52	11224	1	Nameplate
53	27108	1	Nameplate
*	51157	1	Manual
*	13486	1	Connector Kit, DB9 ACC 334
*	27428C	2	Fuse 2A F1, F2
*	27429C	1	Fuse 6.3A F3

* Not pictured in the following Parts Diagrams.

6.2.2. Model 1605 Parts Diagram

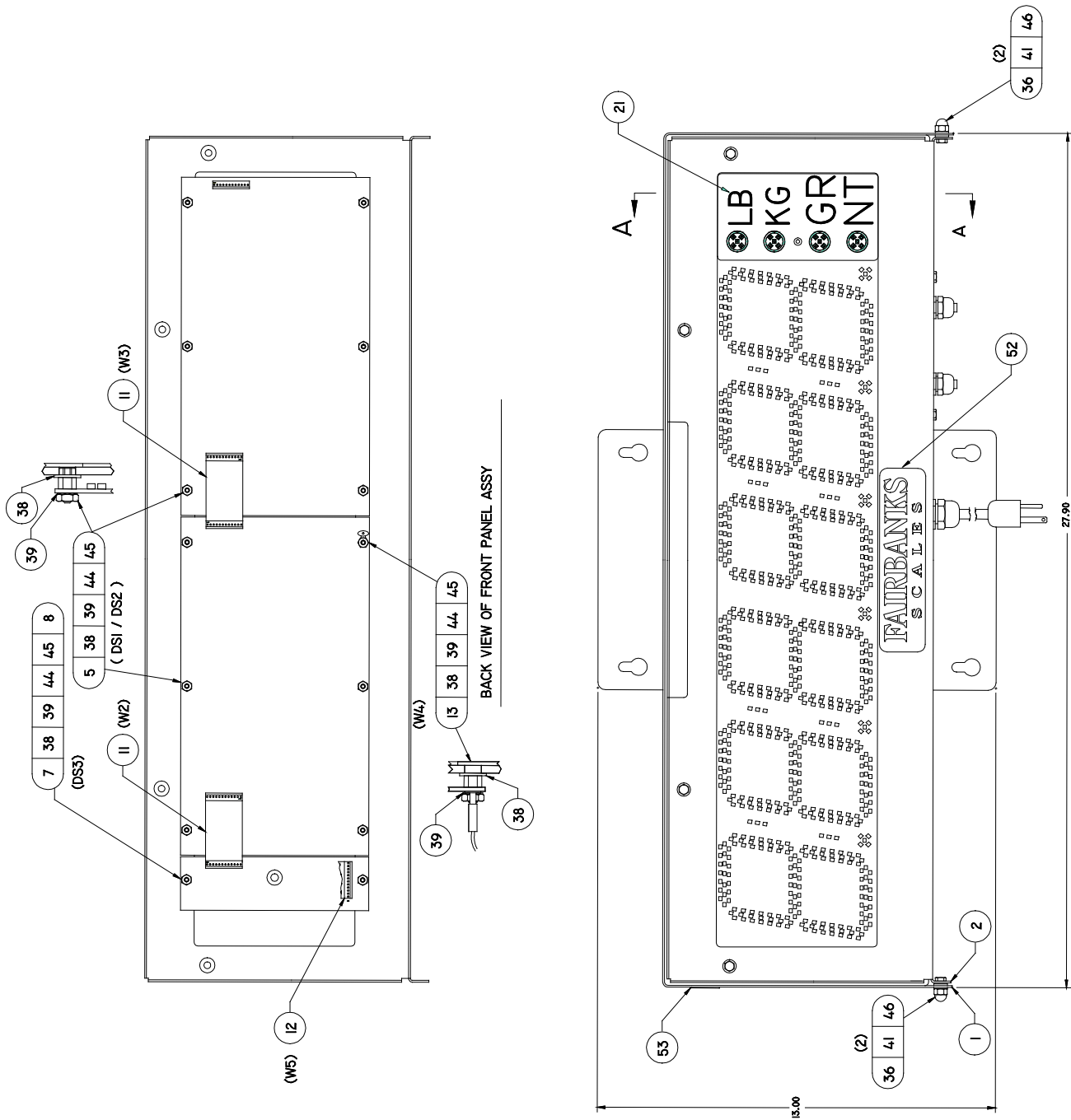

6.2.2. Model 1605 Parts Diagram, Continued

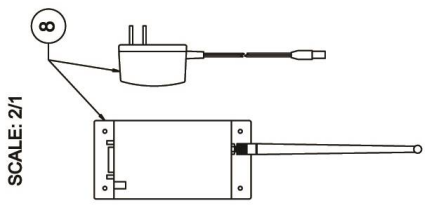
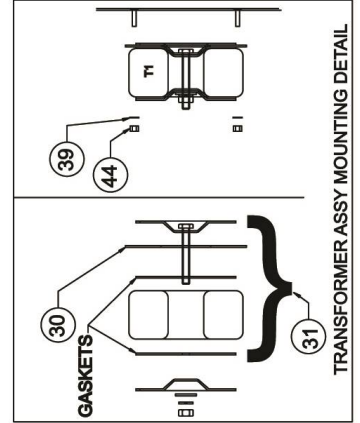
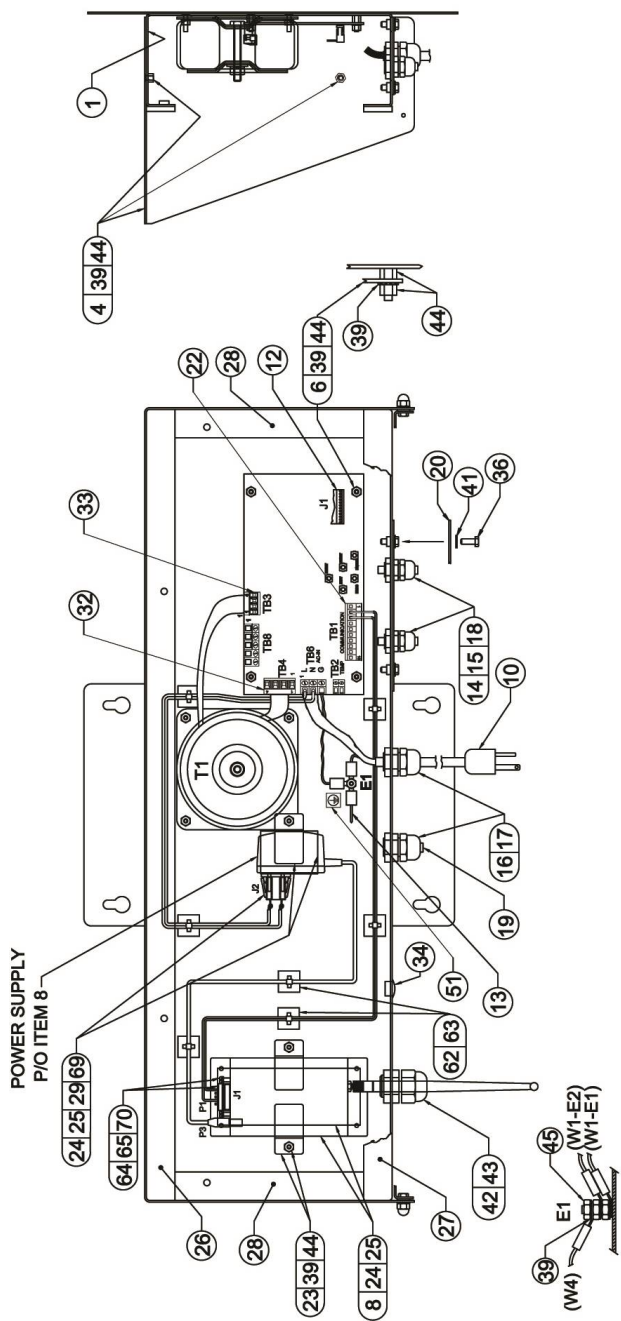

**REMOTE DISPLAY ASSY (5")
WITH RF LINK
RMT-1605-RF
30981**

6.2.2. Model 1605 Parts Diagram, Continued

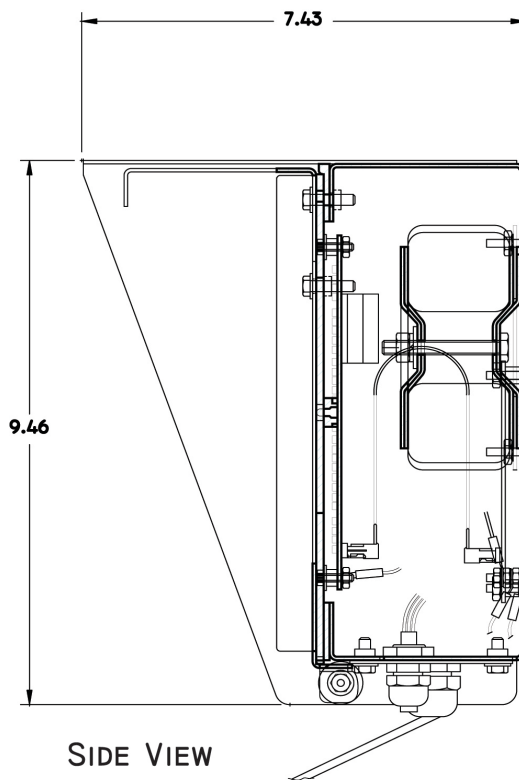
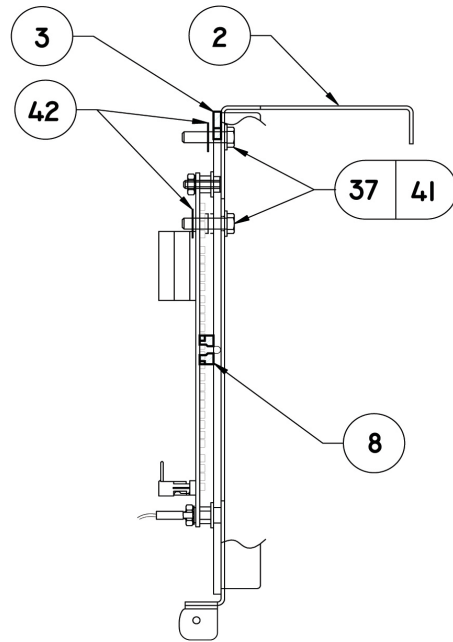

SIDE VIEW

5" REMOTE DISPLAY ASSY
1605 DISPLAY
51157-1

6.3. MODEL 1605RF (30981)

6.3.1. Model 1605RF Parts List

ITEM	PART NO.	QTY	DESCRIPTION	
1	26567	1	ENCLOSURE WELDMENT, MODIFIED	
2	26568	1	FRONT PANEL ASSEMBLY	
3	26569	1	WINDOW	
4	26565	1	PCB ASSY	
5	27212	2	LED DISPLAY PCB ASSEMBLY	DS1, DS2
6	30400	1	CPU PCB ASSEMBLY	A1
7	27531	1	ANNUNCIATOR PCB ASSEMBLY	DS3
8	34986	2	RF MODEM - RS232 XBEE 900 Mhz	
10	15435	1	POWER CORD ASSEMBLY	W1
11	27105	2	CABLE ASSEMBLY	W2, W3
12	27106	1	CABLE ASSEMBLY	W5
13	27109	1	GROUND CABLE ASSEMBLY	W4
14	17545	2	LIQUID TIGHT CONNECTOR	0.50
15	15651	2	O-RING FOR 0.50	
16	17534	2	LIQUID TIGHT CONNECTOR	0.75
17	12342	2	O-RING FOR 0.75	
18	12609	3	NYLON ROD	
19	12011	1	NYLON ROD	
20	26570	1	ACCESS DOOR	
21	27107	1	LEGEND OVERLAY	
22	27432C	1	TERMINAL BLOCK PLUG 10 POSITION	
23	30984	2	RF MODEM CLAMP	
24	14721	6.5 IN	VELCRO, LOOP (CUT INTO 5.00" AND 1.50 LENGTHS)	
25	14722	6.5 IN.	VELCRO, LOOP (CUT INTO 5.00" AND 1.50 LENGTHS)	
26	26572	1	TOP GASKET	
27	26573	1	BOTTOM GASKET	
28	26574	2	SIDE GASKET	
29	29932	1	CLAMP, POWER SUPPLY	
30	26563	1	TRANSFORMER MOUNTING PLATE	
31	27656	1	TRANSFORMER	T1
32	17521	1	TERMINAL PLUG 4-POS 0.295 C-C	XTB4
33	27434C	1	TERMINAL PLUG 4-POS 0.197 C-C	XTB3
34	14225	1	HOLE PLUG 0.50 DIA.	

6.3.1. Model 1605RF Parts List, Continued

ITEM	PART NO.	QTY	DESCRIPTION
36	11075	6	SCREW-CAP-HEX HD. 1032 X 0.50
37	11076	4	SCREW-CAP-HEX HD. 1032 X 0.75
38	10310	14	WASHER, FLAT NO. 6
39	11191	30	WASHER, LOCK, EXT. TOOTH NO. 6
40	11339	1	WASHER, PLAIN (NYLON) NO. 8
41	11495	12	WASHER-PLAIN (NYLON) NO. 10
42	18455	1	CONNECTOR, LIQUIDTIGHT
43	18454	1	O-RING
44	17597	34	SPACER, HEX 6-32 THDS X .19 LONG
45	11102	3	NUT-HEX 6-32
46	15716	2	NUT, THREADLOCK ACORN 10-32
47	11662	12	SPACER, HEX 6-32 THDS X .31 LONG
48	17586	12	STANDOFF, HEX, M/F 6-32 THDS X .25 LONG
51	24366	1	LABEL, GROUND SYMBOL
52	11224	1	NAMEPLATE
53	**27108	1	NAMEPLATE **SAME AS 27108 EXCEPT ASSY NO. IS 30981, AND THE MODEL NUMBER IS RMT-1605-RF
55	13486	1	CONNECTOR KIT DB9 ACC 334
62	17613	7	TIE, WIRE
63	17617	7	MOUNT, CABLE TIE, SELF ADHESIVE
64	10888	2	SCREW, MACH, PH, PHIL 4-40 X .19
65	10919	2	WASHER, LOCK, INT. TOOTH NO. 4
69	31508	1	CABLE ASSY, POWER W6
70	31509	1	CABLE ASSY, COMMUNICATION W7

6.3.2. Model 1605RF Parts Diagram, Exterior

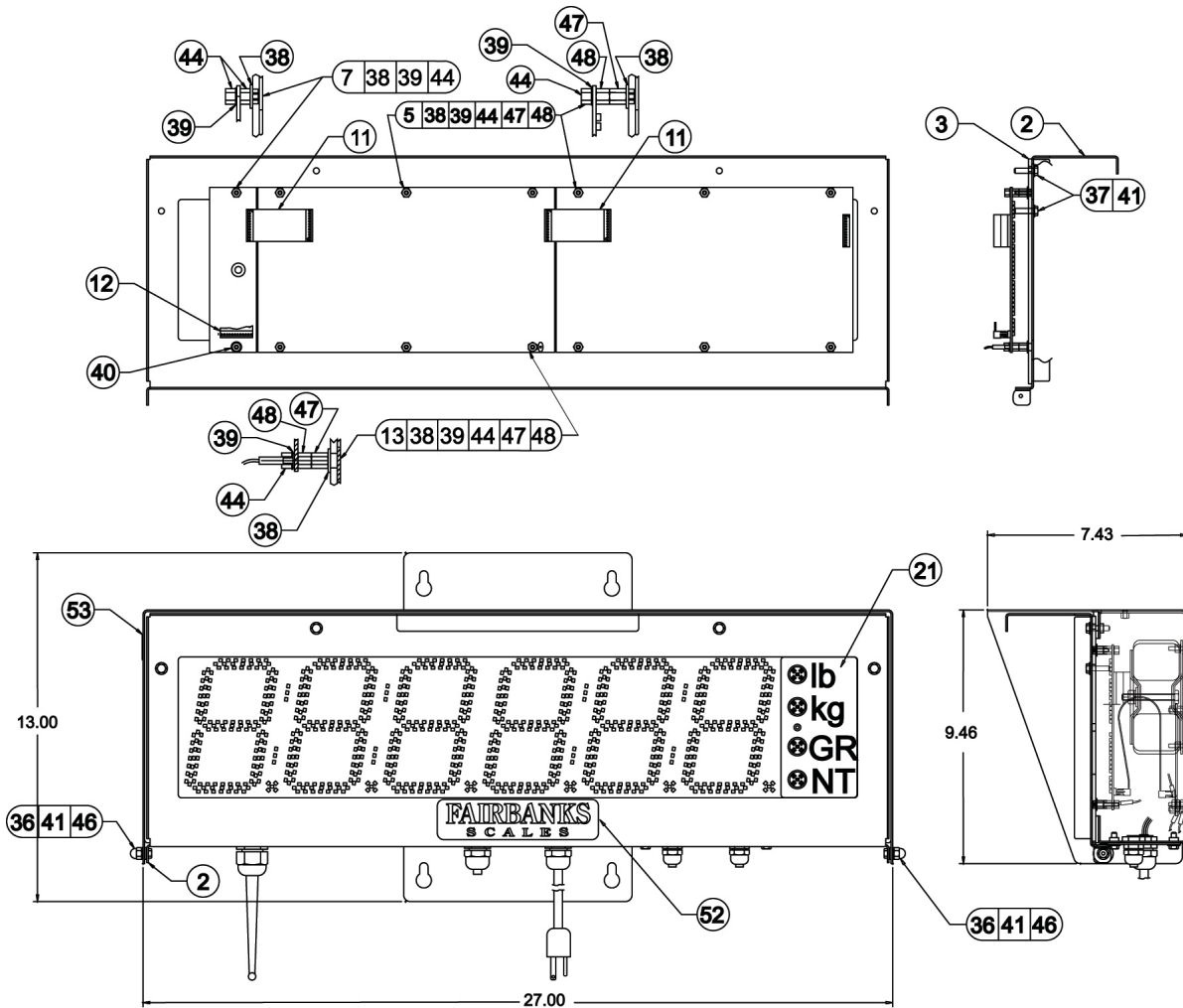

**REMOTE DISPLAY ASSY (5")
WITH RF
RMT-1605-RF
30981**

6.3.3. Model 1605RF Parts Diagram, Interior

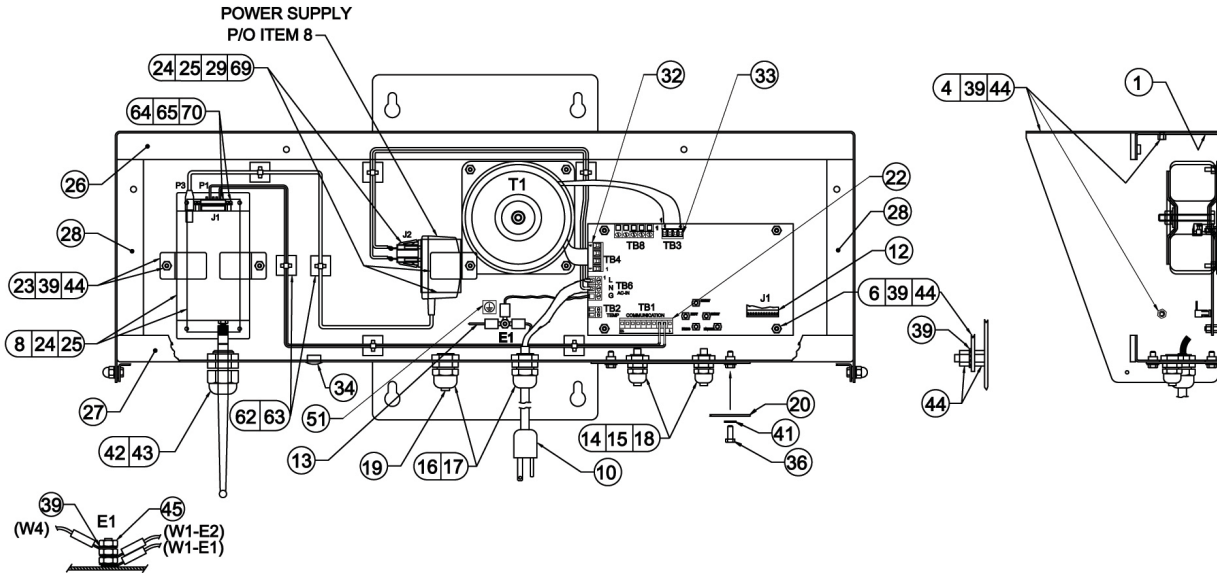

SCALE: 2/1

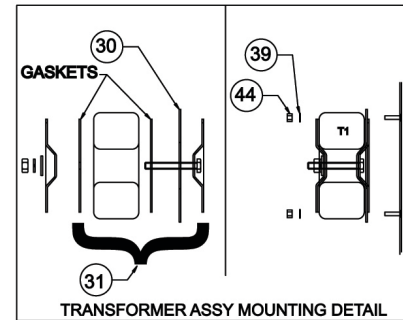
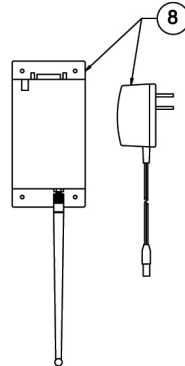

**REMOTE DISPLAY ASSY (5")
WITH RF LINK
RMT-1605-RF
30981**



6.4. MODEL 1605T (29000)

6.4.1. Model 1605T Parts List

ITEM	PART NO.	QTY	DESCRIPTION
1	28986	1	ENCLOSURE WELDMENT
2	28988	1	FRONT PANEL ASSY
3	28991	1	WINDOW, LARGE
4	28987	2	SHROUD ASSY
5	27212	2	PCB ASSY, LED DISPLAY DS1, DS2
6	30400	1	PCB ASSY, CPU A1
7	27531	1	PCB ASSY, ANNUNCIATOR DS3
8	29700	1	PCB ASSY, TRAFFIC LIGHT MODULE
9	28992	1	WINDOW, SMALL
10	15435	1	POWER CORD ASSY W1
11	27105	2	CABLE ASSY W2, W3
12	27106	1	CABLE ASSY W5
13	27109	1	CABLE ASSY, GROUND W4
14	17545	2	CONNECTOR, LIQUIDTIGHT .50
15	15651	2	O-RING FOR .50
16	17534	2	CONNECTOR, LIQUIDTIGHT .75
17	12342	2	O-RING FOR .75
18	12609	2	ROD, NYLON .25 DIA X 1.00
19	12011	1	ROD, NYLON .375 DIA X 1.00
20	26570	1	DOOR, ACCESS
21	27107	1	OVERLAY, LEGEND
22	27432C	1	BLOCK, TERMINAL, PLUG 10 POS XTB1
23	29772	1	CABLE ASSY
24	13223	AR	ADHESIVE, SEALANT RTV
25	29780	1	BRACKET, WINDOW
26	28993	1	GASKET, TOP
27	28994	1	GASKET, BOTTOM
28	26574	2	GASKET, SIDE
29			
30	26563	1	PLATE, TRANSFORMER MOUNTING
31	27656	1	TRANSFORMER T1
32	17521	1	BLOCK, TERMINAL, PLUG 4 POS .295 C-C XTB4
33	27434C	1	BLOCK, TERMINAL PLUG 4 POS .197 C-C XTB3
34	14225	1	PLUG, HOLE .50 DIA
35			



6.4.1. Model 1605T Parts List, Continued

ITEM	PART NO.	QTY	DESCRIPTION
36	11075	6	SCREW-CAP-HEX HD. 10-32 X .50
37	11076	4	SCREW-CAP-HEX HD. 10-32 X .75
38	10310	14	WASHER-FLAT NO. 6
39	11191	33	WASHWER-LOCK-EXT. TOOTH NO. 6
40	11339	1	WASHER-PLAIN (NYLON) NO. 8
41	11495	12	WASHER-PLAIN (NYLON) NO. 10
42			
43			
44	17597	34	SPACER, HEX 6-32 THDS X .19 LONG
45	11102	3	NUT-HEX 6-32
46	15716	2	NUT, THREADLOCK ACORN 10-32
47	17595	12	SPACER, HEX 6-32 THDS X .31 LONG
48	17586	12	STANDOFF, HEX M/F 6-32 THDS X .25 LONG
49			
50	29081	1	ETL MARK LABEL
51	24366	1	LABEL, GROUND SYMBOL
52	11224	1	NAMEPLATE
53	29771	1	NAMEPLATE
55	13486	1	CONNECTOR KIT DB9 ACC 334
56	17509	1	PLUG, TERMINAL 5 POS .197 C-C

6.4.2. Model 1605T Parts Diagram, Exterior

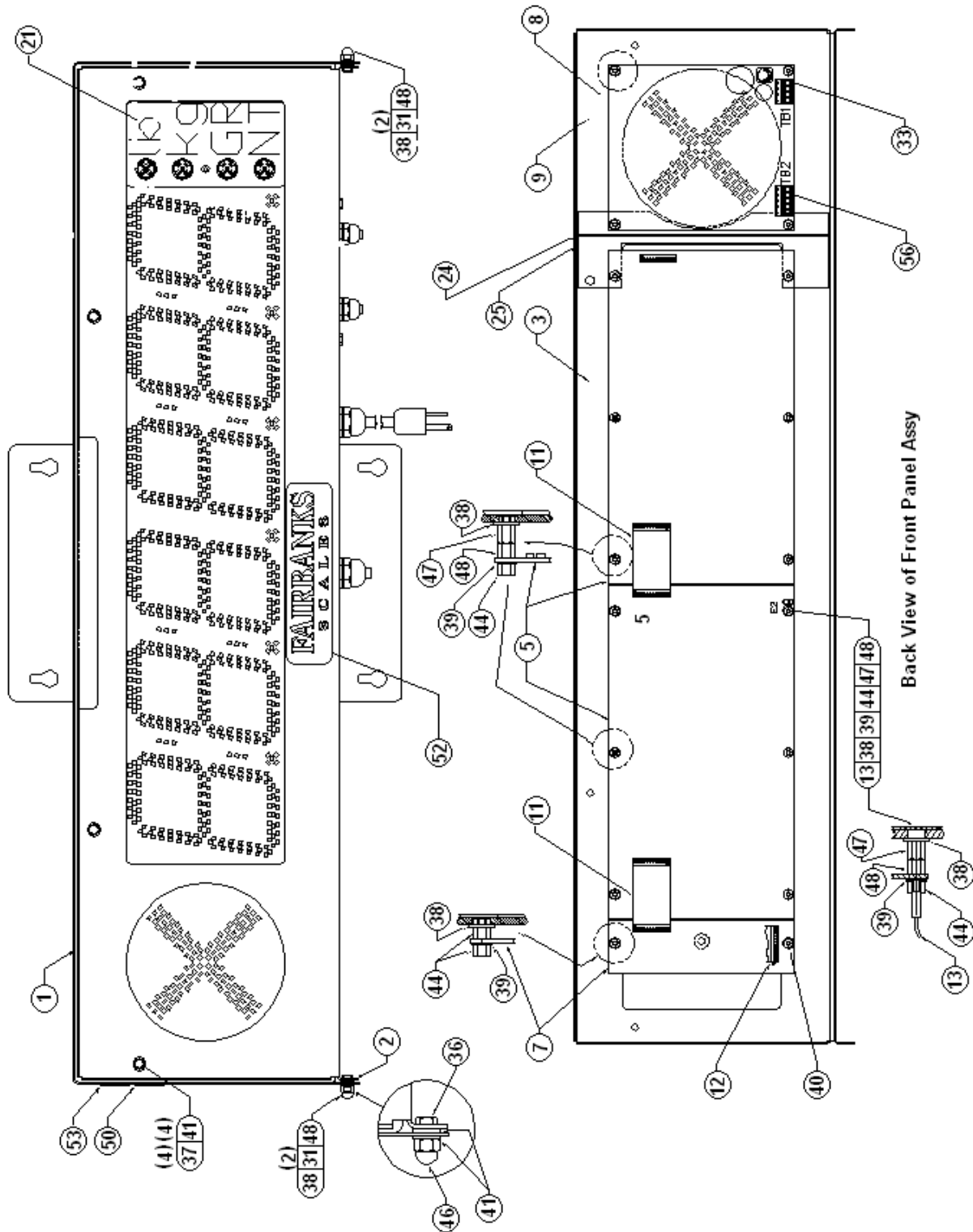

6.4.3. Model 1605T Parts Diagram, Interior

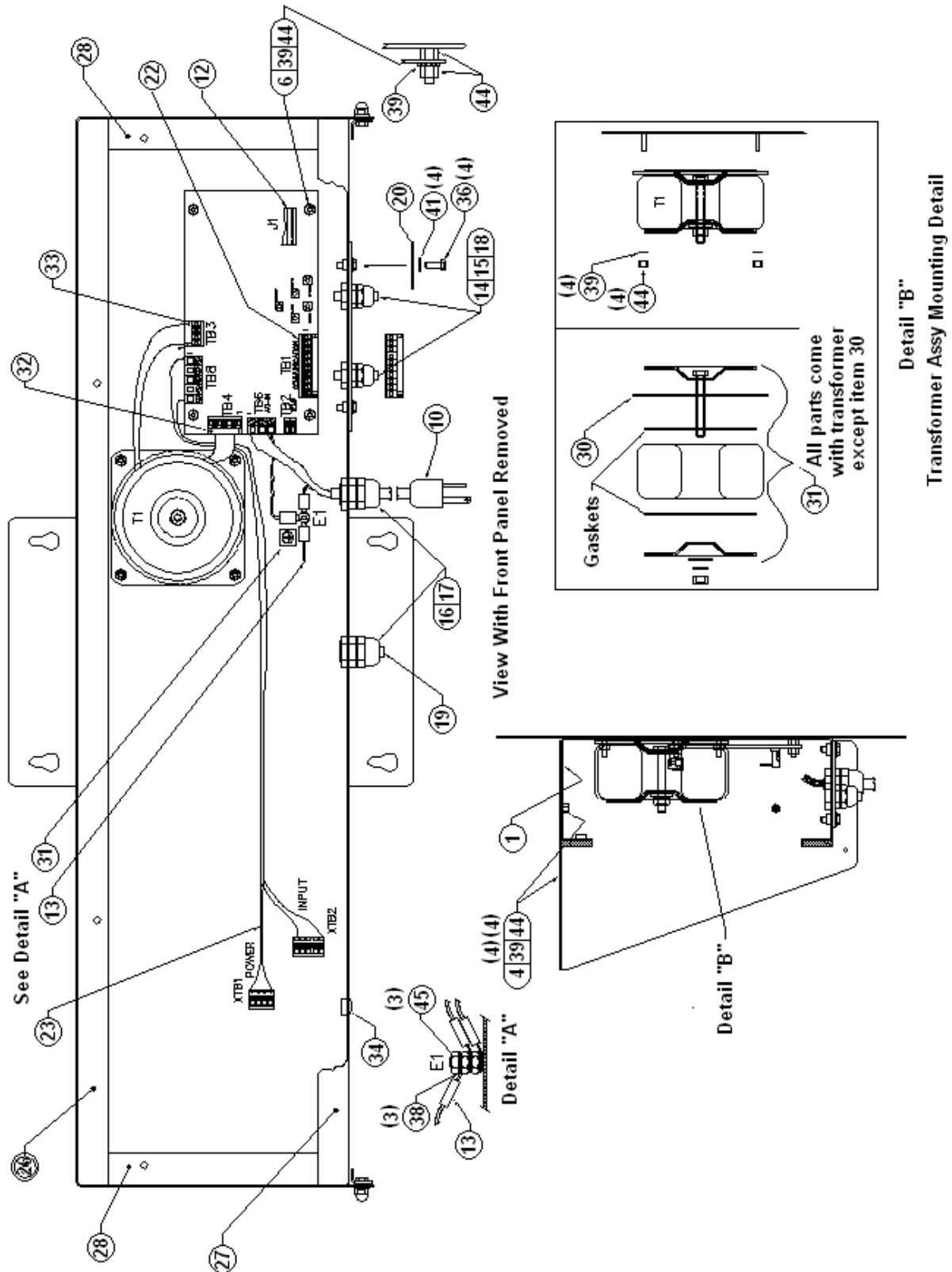

6.5. MODEL 1605T-RF (31934)

6.5.1. Model 1605T-RF Parts List

ITEM	PART NO.	QTY	DESCRIPTION
1	28986	1	ENCLOSURE WELDMENT, MODIFIED
2	28988	1	FRONT PANEL ASSEMBLY
3	28991	1	WINDOW LARGE
4	28987	1	SHROUD ASSY
5	27212	2	LED DISPLAY PCB ASSEMBLY DS1, DS2
6	30400	1	CPU PCB ASSEMBLY A1
7	27531	1	ANNUNCIATOR PCB ASSEMBLY DS3
8	29700	1	TRAFFIC LIGHT MODULE PCB ASSY
9	28992	1	WINDOW, SMALL
10	15435	1	POWER CORD ASSEMBLY W1
11	27105	2	CABLE ASSEMBLY W2, W3
12	27106	1	CABLE ASSEMBLY W5
13	27109	1	GROUND CABLE ASSEMBLY W4
14	17545	2	LIQUID TIGHT CONNECTOR 0.50
15	15651	2	O-RING FOR 0.50
16	17534	2	LIQUID TIGHT CONNECTOR 0.75
17	12342	2	O-RING FOR 0.75
18	12609	3	NYLON ROD
19	12011	1	NYLON ROD
20	26570	1	ACCESS DOOR
21	27107	1	LEGEND OVERLAY
22	27432C	1	TERMINAL BLOCK PLUG 10 POSITION
23	29772	1	CABLE ASSY TO TRAFFIC LIGHT FROM CPU
24	13223	AR	RTV ADHESIVE SEALANT
25	29780	1	WINDOW BRACKET
26	28993	1	TOP GASKET
27	28994	1	BOTTOM GASKET
28	26574	2	SIDE GASKET
29	29932	1	CLAMP, POWER SUPPLY
30	26563	1	TRANSFORMER MOUNTING PLATE
31	27656	1	TRANSFORMER T1
32	17521	1	TERMINAL PLUG 4-POS 0.295 C-C XTB4
33	27434C	1	TERMINAL PLUG 4-POS 0.197 C-C XTB3
34	14225	1	HOLE PLUG 0.50 DIA.

6.5.1. Model 1605T-RF Parts List, continued

ITEM	PART NO.	QTY	DESCRIPTION
36	11075	6	SCREW-CAP-HEX HD. 1032 X 0.50
37	11076	4	SCREW-CAP-HEX HD. 1032 X 0.75
38	10310	14	WASHER, FLAT NO. 6
39	11191	35	WASHER, LOCK, EXT. TOOTH NO. 6
40	11339	1	WASHER, PLAIN (NYLON) NO. 8
41	11495	12	WASHER-PLAIN (NYLON) NO. 10
42	18455	1	CONNECTOR, LIQUIDTIGHT
43	18454	1	O-RING
44	17597	38	SPACER, HEX 6-32 THDS X .19 LONG
45	11102	3	NUT-HEX 6-32
46	15716	2	NUT, THREADLOCK ACORN 10-32
47	11662	16	SPACER, HEX 6-32 THDS X .31 LONG
48	17586	16	STANDOFF, HEX, M/F 6-32 THDS X .25 LONG
51	24366	1	LABEL, GROUND SYMBOL
52	11224	1	NAMEPLATE
53	31935	1	NAMEPLATE
55	13486	1	CONNECTOR KIT DB9 ACC 334
56	30984	2	RF MODEM CLAMP
57	14721	6.5 IN	VELCRO, LOOP (CUT INTO 5.00" AND 1.50 LENGTHS)
58	14722	6.5 IN.	VELCRO, LOOP (CUT INTO 5.00" AND 1.50 LENGTHS)
60	34986	2	RF MODEM - RS232 XBEE 900 Mhz
62	17613	7	TIE, WIRE
63	17617	7	MOUNT, CABLE TIE, SELF ADHESIVE
64	10888	2	SCREW, MACH, PH, PHIL 4-40 X .19
65	10919	2	WASHER, LOCK, INT. TOOTH NO. 4
69	31508	1	CABLE ASSY, POWER W6
70	31509	1	CABLE ASSY, COMMUNICATION W7

6.5.2. Model 1605T-RF Parts Diagram, Exterior

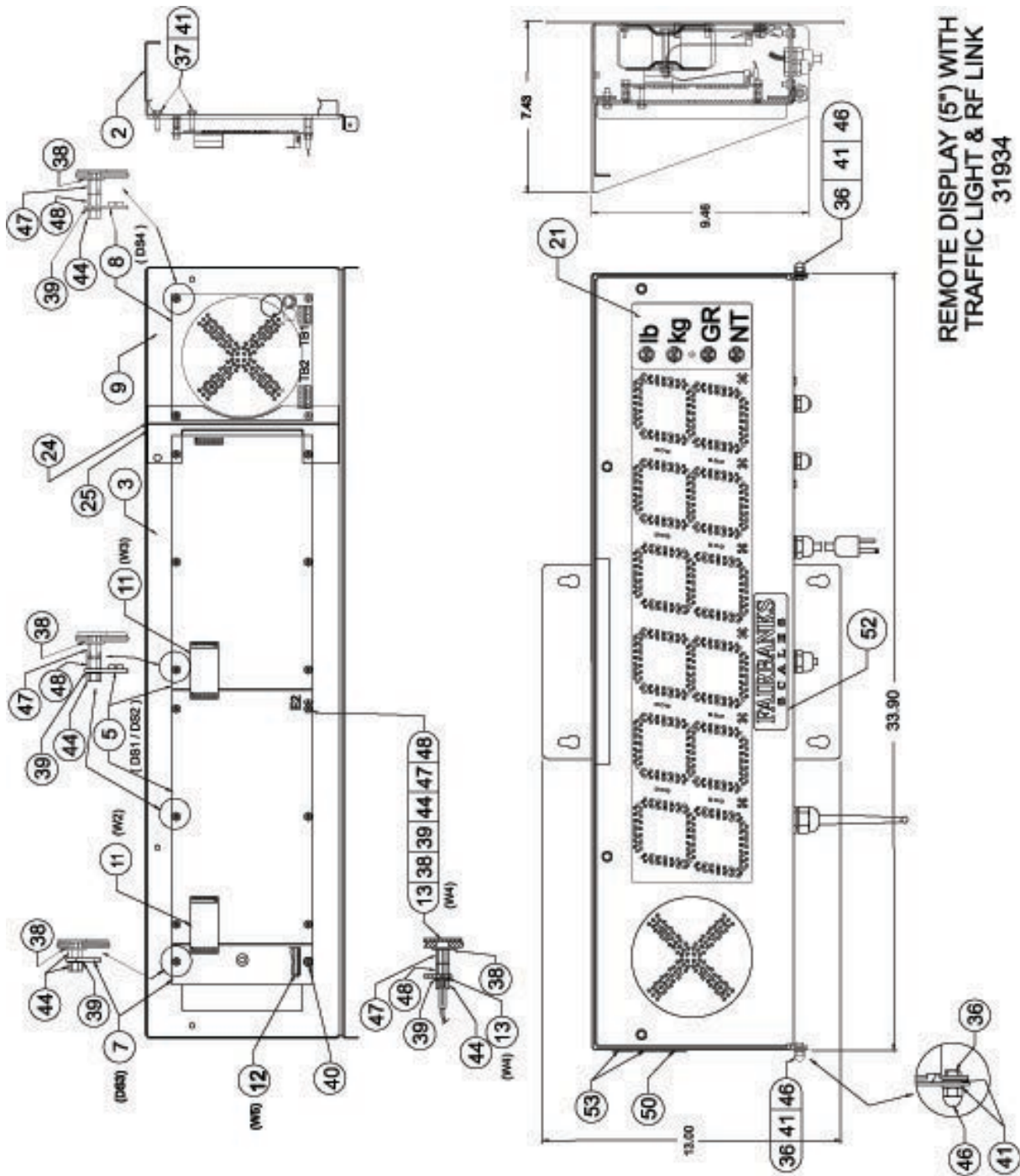

6.5.3. Model 1605T-RF Parts Diagram, Interior

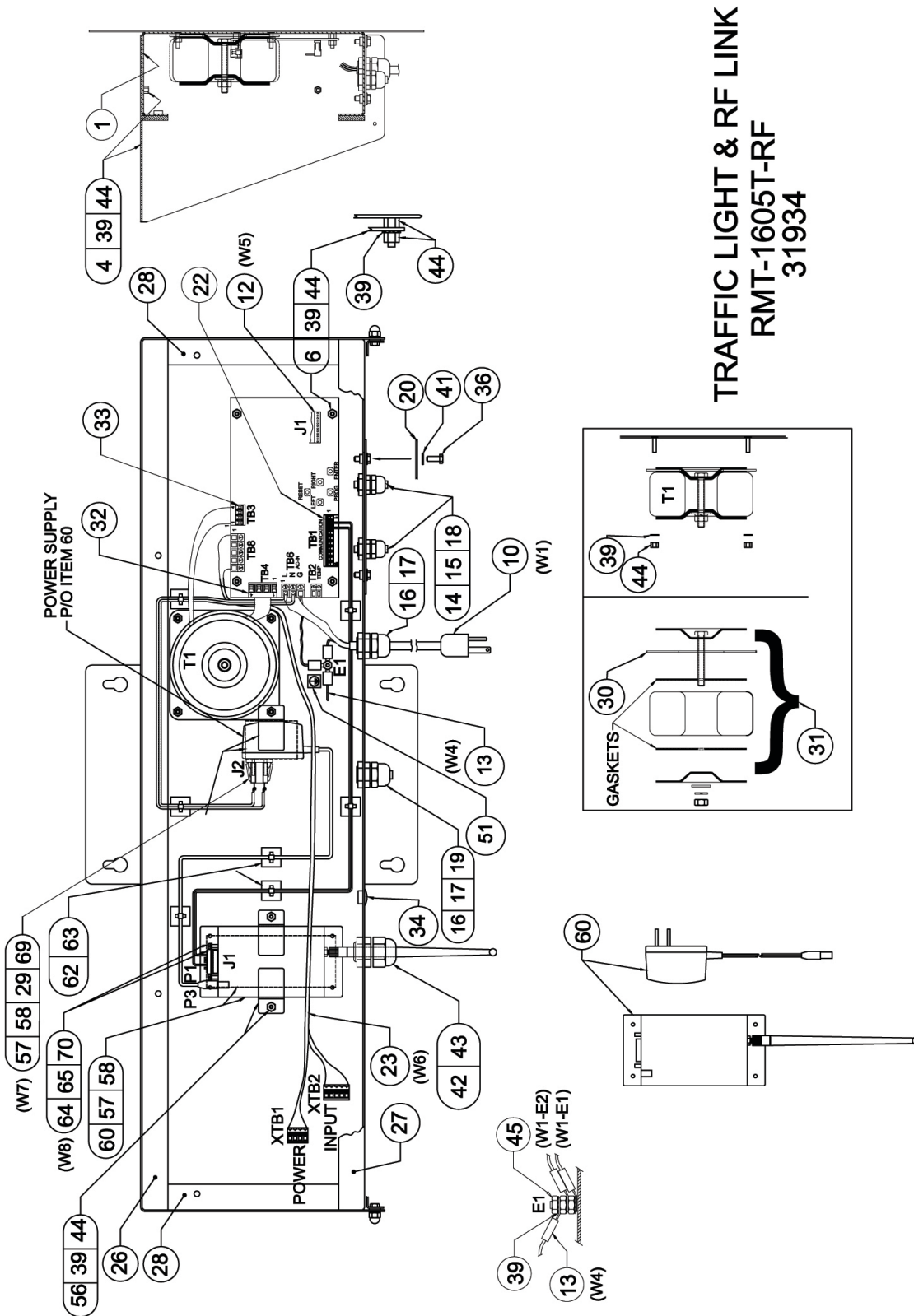

6.6. MODEL 777 (29001)

6.6.1. Model 777 Parts List

ITEM	PART NO.	QTY	DESCRIPTION
1	28996	1	ENCLOSURE WELDMENT
2	28998	1	FRONT PANEL ASSY
3	29002	1	WINDOW
4	28997	2	SHROUD ASSY
5	29700	1	PCB ASSY, TRAFFIC LIGHT MODULE
6			
7			
8			
9			
10	17502	1	BLOCK, TERMINAL END TB3
11	17501	1	BLOCK, TERMINAL TB3
12			
13	27109	1	CABLE ASSY, GROUND
14	17545	1	CONNECTOR, LIQUIDTIGHT .50
15	15651	1	O-RING FOR .50
16	17534	1	CONNECTOR, LIQUIDTIGHT .75
17	12342	1	O-RING FOR .75
18	12609	1	ROD, NYLON .25 DIA X 1.00
19	12011	1	ROD, NYLON .38 DIA X 1.00
20			
21	12100	1	PLUG, HOLE .875 DIA
22	29289	3	PLUG, HOLE .875 DIA
23			
24	17429	1	CLAMP, GROUND
25			
26	28995	2	GASKET, TOP AND BOTTOM
27			
28	26574	2	GASKET, SIDE
29			
30			
31	27656	1	TRANSFORMER
32	27434C	1	PLUG, TERMINAL 4 POS .197 C-C
33	17509	1	PLUG, TERMINAL 5 POS .197 C-C
34	11141	2	SCREW-MACH-PAN HD-PHIL 6-32 X .50
35			

6.6.1 Model 777 Parts List, Continued

ITEM	PART NO.	QTY	DESCRIPTION
36	11075	2	SCREW-CAP-HEX HD. 10-32 X .50
37	11076	2	SCREW-CAP-HEX HD. 10-32 X .50
38	10310	7	WASHER-FLAT NO. 6
39	11191	17	WASHER-LOCK-EXT. TOOTH NO. 6
40	11339	2	WASHER-PLAIN (NYLON) NO. 8
41	11495	6	WASHER-PLAIN (NYLON) NO. 10
42			
43			
44	17597	13	SPACER, HEX 6-32 THDS X .19 LONG
45	11102	2	NUT-HEX 6-32
46	15716	2	NUT, THREADLOCK ACORN 10-32
47	17595	6	SPACER, HEX 6-32 THDS X .31 LONG
48	17586	4	STANDOFF, HEX, M/F 6.32 THDS X .25 LONG
49			
50	29081	1	ETL MARK LABEL
51	34366	1	LABEL, GROUND SYMBOL
52	11226	1	NAMEPLATE
53	29770	1	NAMEPLATE

6.6.2. Model 777 Parts Diagram

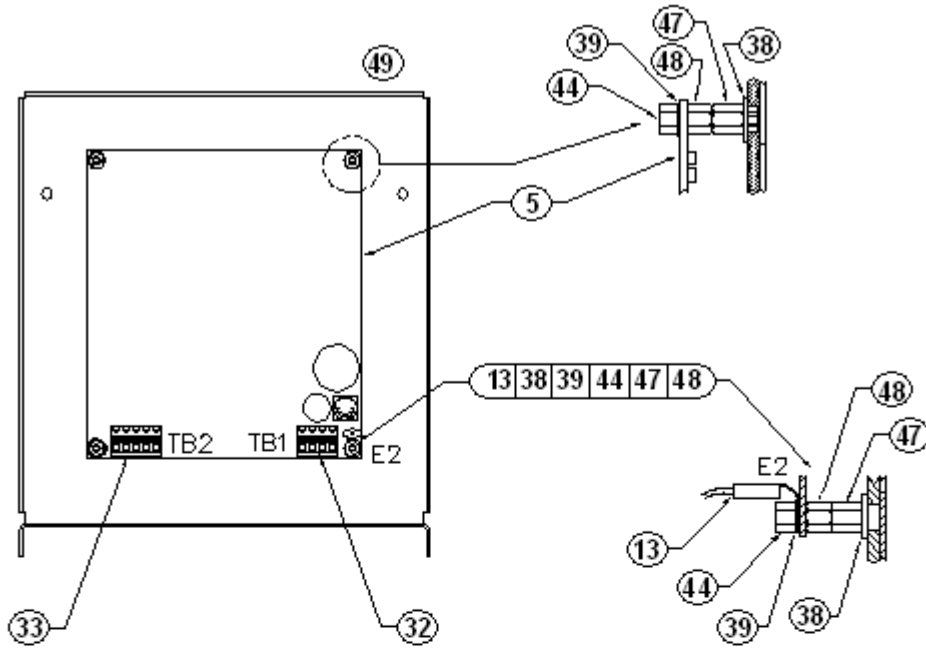

BACK VIEW OF FRONT PANEL ASSY

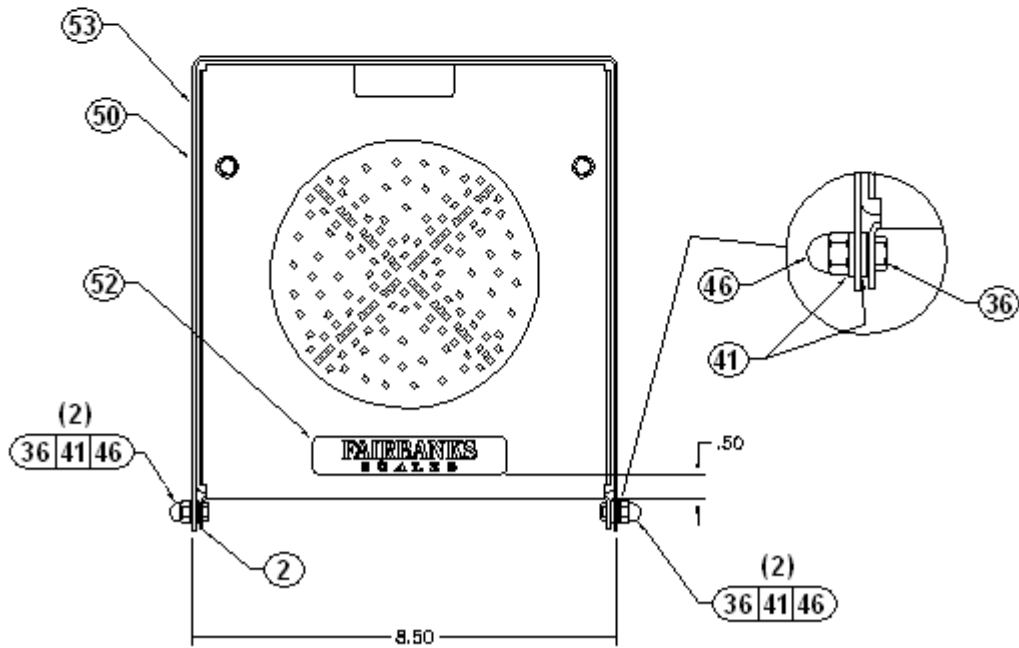

6.6.2. Model 777 Parts Diagram, Continued

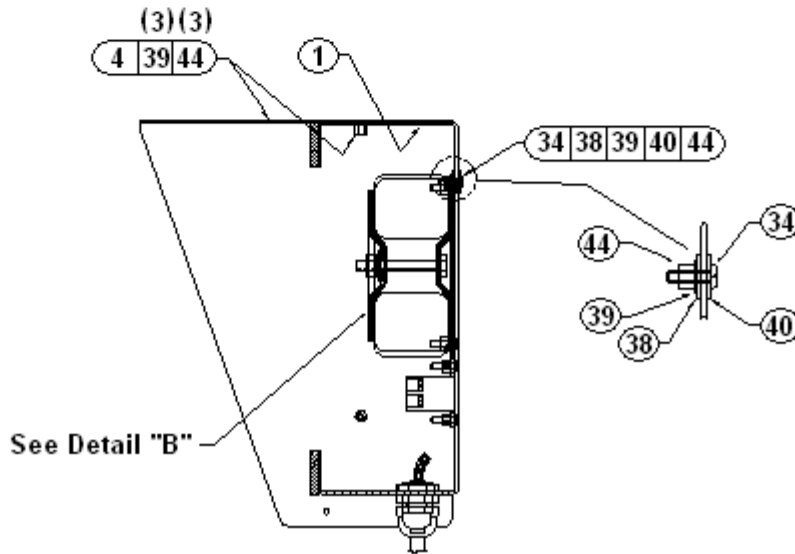
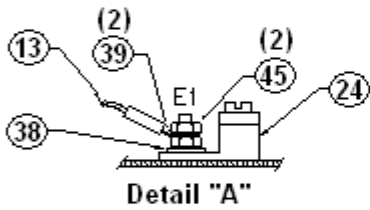
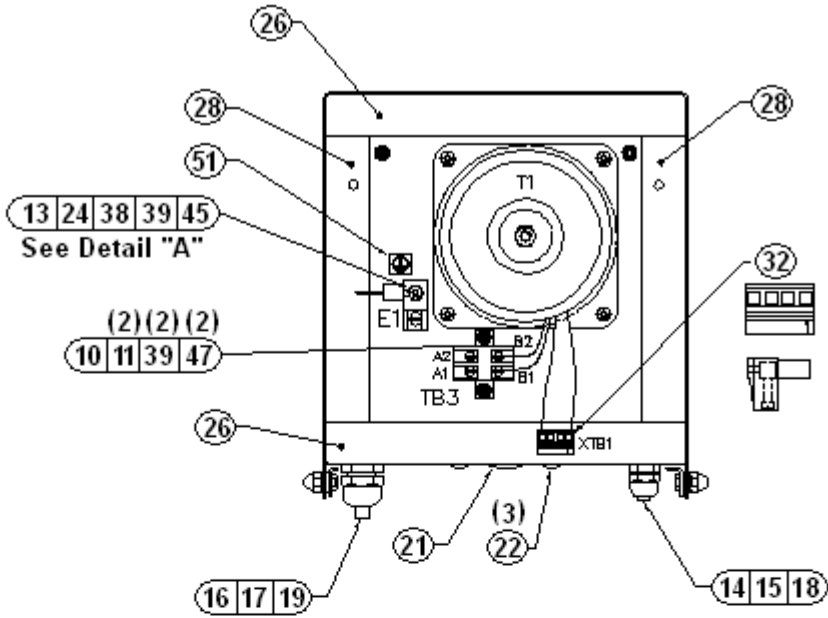

6.6.2. Model 777 Parts Diagram, Continued

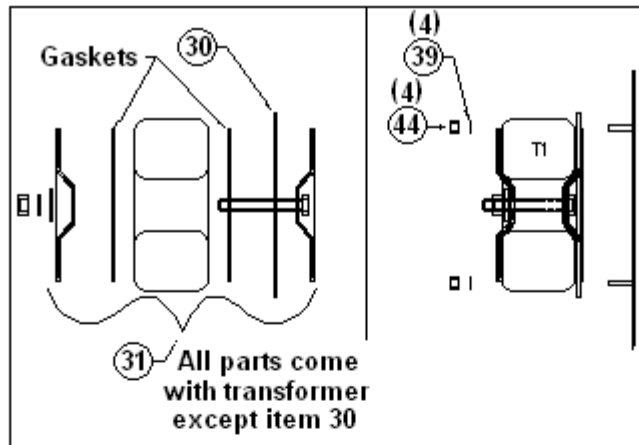

Detail "B"
Transformer Assy Mounting Detail

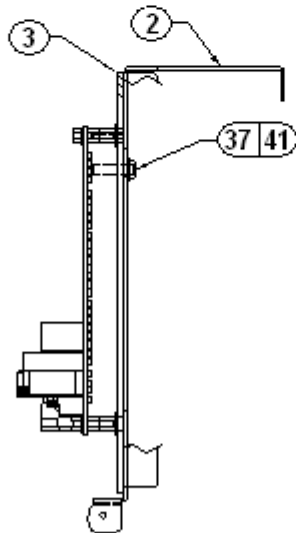

Appendix I: FB350 Programming

With the remote display **ID** set to **00**, set the **FB350** parameters to the following.

Motion Stability Time step 115	=	.2 or less
Update Rate step 117	=	.5 or longer
Parity step 202	=	None
Stop Bit step 203	=	One (1) Bit
Handshake step 204	=	None
Sent step 210	=	Continuous

Appendix II: 2500 Series Programming

Follow these steps to configure the **2500 Instrument** so it interfaces with the **1600 Series Display**.

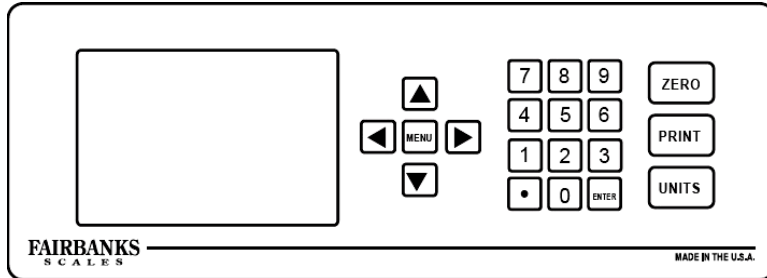

1. Press **MENU** button to open the **Configuration Menu**.
2. Using the **UP** and **DOWN** arrow buttons, select **COMMUNICATION**.
3. Using the **UP** and **DOWN** arrow buttons, select **REMOTE DISPLAY**.
4. Using the **UP** and **DOWN** arrow buttons, select **GROSS ONLY**.
 - ✓ *If using the **2500 Indicator TIME OUTPUT** setting under the Remote Display menu selection the **1605** time display will be overridden, and the **2500** time will be displayed.*
 - ✓ *If **RF LINK TO COM3** is selected ensure **COM3** is set to **COM PORT OFF** in the **DEVICES** menu.*
5. Press **MENU** button repeatedly to exit.

NOTE: For more information about programming the **2500 Series Instrument**, see one of the following manuals:

- **50525** – IND-R2500-F1 IND-HR2500-F1 Indicators **Service Manual**
 - **50697** – IND-2500-F2, DF2, IND-HR2500-F2, DF2 Indicators **Service Manual**
 - **50698** – IND-HR2500-F2 Indicator **Service Manual**
 - **50740** – IND-HR2500-F1 Indicator **Service Manual**
-

NOTE: If using a custom string from the **2500** make sure that leading zeroes are disabled in the weight string to prevent all digits from lighting.

Appendix III: CPU Assembly – Previous vs. Current Models

Shown below is a diagram of the CPU model *previous* to 10/11.

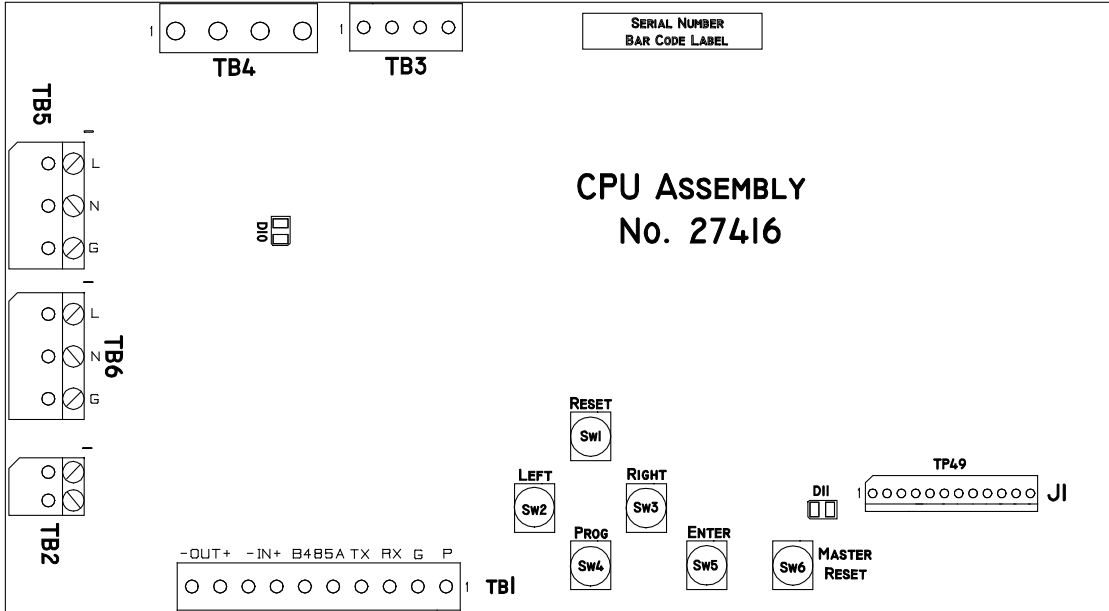

Shown below is a diagram of the *current* CPU Assembly.

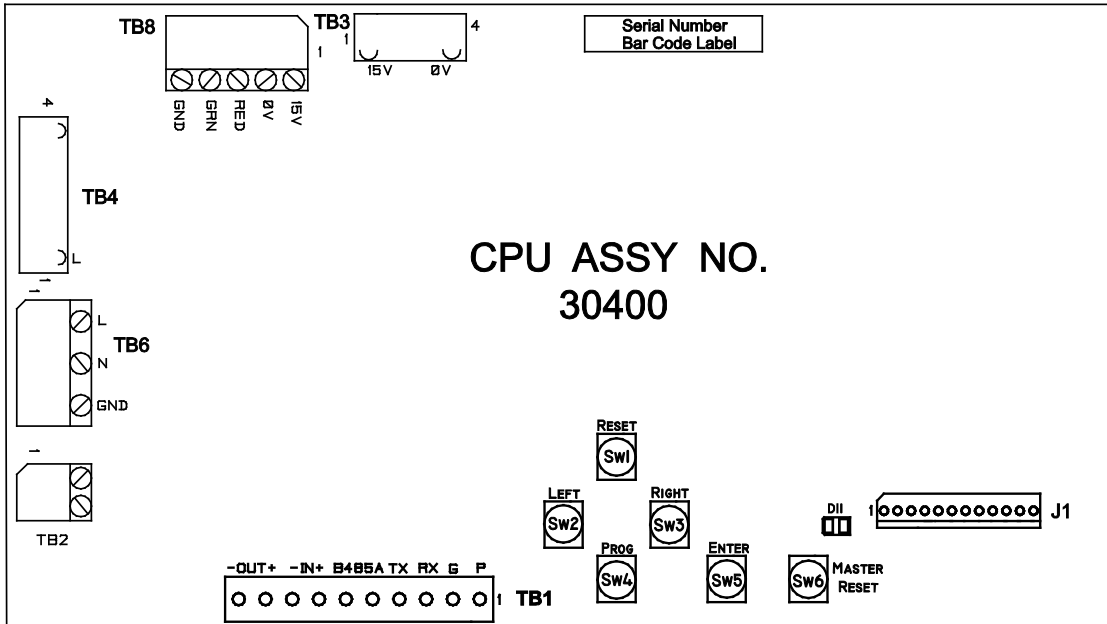

A. 1601 (30400) –CPU Assy Wiring Chart (1-1/2” Display)

WIRE NO.	FROM		WIRE				RTE	TO		REMARKS
	TERMINATION	NOTE	ITEM #	COLOR	GAGE	LGTH		TERMINATION	NOTE	
1	W1-BR	–	10	BR	–	–	–	TB6-1	3	AC
2	W1-BL	–	10	BL	–	–	–	TB6-2	3	ACC
3	W1E1	–	10	G/Y	–	–	–	E1	3	CHASSIS GND
4	W1E2	–	10	G/Y	–	–	–	E1	3	CHASSIS GND
5	W1E2	–	10	G/Y	–	–	–	TB6-3	3	GND
6	T1-W	–	31	W	–	–	–	TB4-1	3	OV
7		–			–	–	–			
8		–			–	–	–			
9	T1-B	–	31	B	–	–	–	TB4-4	3	110 VAC
10	T1-BL	–	31	BL	–	–	–	TB3-1	3	OV
11	T1-BL	–	31	BL	–	–	–	TB3-4	3	20V/8A

B. 1605 and 1605RF (30400) –CPU Assy Wiring Chart (5” Display)

WIRE NO.	FROM		WIRE				RTE	TO		REMARKS
	TERMINATION	NOTE	ITEM #	COLOR	GAGE	LGTH		TERMINATION	NOTE	
1	W1-BR	–	10	BR	–	–	–	TB6-1	3	AC
2	W1-BL	–	10	BL	–	–	–	TB6-2	3	ACC
3	W1E1	–	10	G/Y	–	–	–	E1	3	CHASSIS GND.
4	W1E2	–	10	G/Y	–	–	–	E1	3	CHASSIS GND.
5	W1E2	–	10	G/Y	–	–	–	TB6-3	3	GND.
6	T1-BLK	–	31	BLK	–	–	–	TB4-1	3	110 VAC
7	T1-BRN	–	31	BRN	–	–	–	TB4-2	3	110 VAC
8	T1-WHT	–	31	WHT	–	–	–	TB4-3	3	OV
9	T1-ORG	–	31	ORG	–	–	–	TB4-4	3	OV
10	T1-YEL	–	31	YEL	–	–	–	TB3-1	3	OV
11	T1-RED	–	31	RED	–	–	–	TB3-4	3	15V/2.67A
12	T1-BLU	–	31	BLU	–	–	–	TB3-2	3	OV
13	T1-GRY	–	31	GRY	–	–	–	TB3-3	3	15V/2.67A

C. 1605T and 1605T-RF (30400) –CPU Assembly Wiring Chart (5” Display)

WIRE NO.	FROM		WIRE				RTE	TO		REMARKS
	TERMINATION	NOTE	ITEM #	COLOR	GAGE	LGTH		TERMINATION	NOTE	
1	W1-BR	–	10	BR	–	–	–	TB6-1	3	AC
2	W1-BL	–	10	BL	–	–	–	TB6-2	3	ACC
3	W1E1	–	10	G/Y	–	–	–	E1	3	CHASSIS GND.
4	W1E2	–	10	G/Y	–	–	–	E1	3	CHASSIS GND.
5	W1E2	–	10	G/Y	–	–	–	TB6-3	3	GND.
6	T1-BLK	–	31	BLK	–	–	–	TB4-1	3	110 VAC
7	T1-BRN	–	31	BRN	–	–	–	TB4-2	3	110 VAC
8	T1-WHT	–	31	WHT	–	–	–	TB4-3	3	OV
9	T1-ORG	–	31	ORG	–	–	–	TB4-4	3	OV
10	T1-YEL	–	31	YEL	–	–	–	TB3-1	3	OV
11	T1-BLU	–	31	BLU	–	–	–	TB3-2	3	OV
12	T1-GRY	–	31	GRY	–	–	–	TB3-3	3	15V/2.67A
13	T1-RED	–	31	RED	–	–	–	TB3-4	3	15V/2.67A
14	W4-E1	–	13	GRN	–	–	–	W4-E2	3	CHASSIS GND.
15										
16	W6-BK	–	23	BLK	–	–	–	TB8-1	3	15V/2.67A
17	W6-WHT	–	23	WHT	–	–	–	TB8-2	3	OV
18	W6-RED	–	23	RED	–	–	–	TB8-3	3	RED LIGHT
19	W6-GRN	–	23	GRN	–	–	–	TB8-4	3	GREEN LIGHT
19	W6-YEL	–	23	YEL	–	–	–	TB8-5	3	GROUND



D. 1605 (30400) –CPU Assembly Wiring Chart (1-1/2” Display)

WIRE NO.	FROM		WIRE				RTE	TO		REMARKS
	TERMINATION	NOTE	ITEM #	COLOR	GAGE	LGTH		TERMINATION	NOTE	
1	W1-BR	-	10	BR	-	-	-	TB6-1	3	AC
2	W1-BL	-	10	BL	-	-	-	TB6-2	3	ACC
3	W1E1	-	10	G/Y	-	-	-	E1	3	CHASSIS GND
4	W1E2	-	10	G/Y	-	-	-	E1	3	CHASSIS GND
5	W1E2	-	10	G/Y	-	-	-	TB6-3	3	GND
6	T1-W	-	31	W	-	-	-	TB4-1	3	OV
7	T1-W	-	31	W	-	-	-	TB4-2	3	OV
8	TB-W	-	31	B	-	-	-	TB4-3	3	110 VAC
9	T1-B	-	31	B	-	-	-	TB4-4	3	110 VAC
10	T1-BL	-	31	BL	-	-	-	TB3-1	3	OV
11	T1-BL	-	31	BL	-	-	-	TB3-4	3	20V/8A

NOTE: *The wiring chart listed above is for the CPU Card part number 27416, which is an older, obsolete version.*

Appendix IV: 20mA Codes

CODE	UNITS	WEIGHT	SCALE #
00 – Display all data			
40	Lbs	Gross	1
41	Lbs	Net	1
42	Lbs	Tare	1
43	Kg	Gross	1
44	Kg	Net	1
45	Kg	Tare	1
46	Lbs	Gross	2
47	Lbs	Net	2
48	Lbs	Tare	2
49	Kg	Gross	2
50	Kg	Net	2
51	Kg	Tare	2
52	Lbs	Gross	3
53	Lbs	Net	3
54	Lbs	Tare	3
55	Kg	Gross	3
56	Kg	Net	3
57	Kg	Tare	3
58	Lbs	Gross	4
59	Lbs	Net	4
60	Lbs	Tare	4
61	Kg	Gross	4
62	Kg	Net	4
63	Kg	Tare	4



Appendix IV: 20mA Codes, continued

CODE	UNITS	WEIGHT	SCALE #
64	Lbs	Gross	5
65	Lbs	Net	5
66	Lbs	Tare	5
67	Kg	Gross	5
68	Kg	Net	5
69	Kg	Tare	5
70	Lbs	Gross	6
71	Lbs	Net	6
72	Lbs	Tare	6
73	Kg	Gross	6
74	Kg	Net	6
75	Kg	Tare	6
76	Lbs	Gross	7
77	Lbs	Net	7
78	Lbs	Tare	7
79	Kg	Gross	7
80	Kg	Net	7
81	Kg	Tare	7
82	Lbs	Gross	8
83	Lbs	Net	8
84	Lbs	Tare	8
85	Kg	Gross	8
86	Kg	Net	8
87	Kg	Tare	8

Appendix V: Data Input

A. REMOTE DISPLAY INPUT

Data Format

<STX><4><0><SP/-><XXXXXX><ETX>

Note(s):

1. Characters denoted by **X** are characters 0-9.
 2. Leading zeroes are suppressed.
 3. Polarity indication for a positive value is a space (**SP**).
 - Negative values are not transmitted.
 4. **Identifier code <4><0> = Gross weight.**
 - Transmission is **Gross Only**.
 5. Transmission for the **DEMAND Mode** occurs when a carriage return (**CR**) Hex **0D** is received.
-



1600 Series Remote Display

DOCUMENT 51157

Manufactured by Fairbanks Scales Inc.
821 Locust
Kansas City, Missouri 64106