

FAIRBANKS®

S C A L E S



FB6000 SERIES

TRUCK SCALE INSTRUMENTS FOR MID-RANGE APPLICATIONS

High performance, user-friendly instruments for in/out, gross/tare/net, or basic one-button in/out vehicle weighing on a single scale platform. Available in three enclosure types and with analog or digital load cell interface.

FB6000 SERIES

TRUCK SCALE INSTRUMENTS FOR MID-RANGE APPLICATIONS

Instruments that deliver all the features needed for successful inbound/outbound weighing.

Your vehicle scale is an essential and critical component of your daily business operations. Weighing equipment that is flexible, reliable and durable is not a luxury, it is a requirement.

For more than 185 years, Fairbanks Scales has led the vehicle weighing industry with products that fit customer application needs —

needs like yours. The FB6000 Series Instrument carries this tradition forward as the dependable weighing solution for your operation.

The FB6000 features three modes of operation, three enclosure styles, built-in traffic controls, multiple communication ports and transaction export functions to meet your application requirements.

Washdown Desktop/Wall Mount Enclosure



Panel Mount Enclosure



Stainless steel and powder coated NEMA 12 enclosure

Bright red, 16-segment LED with adjustable intensity

Raised keys provide tactile feedback and audible notification when pressed.

Desktop Enclosure



Front panel navigation keys

Full numeric keypad with oversized keys

Intalogix® Technology: Digital at its Best

Intalogix® Technology is a unique method of digital load cell communication that works by converting an analog load cell signal to a stronger, more reliable digital interface. Regardless of the nature of an application, Intalogix® Technology allows

users to operate with an unsurpassed degree of resolution and accuracy. No other technology on today's market comes close to achieving the digital advantages and lightning/surge protection of Intalogix®.

Function Key Features (See callouts above)

1 UNITS — Four selectable units of measure:

- Pounds
- Kilograms
- Tons
- Tonnes

2 B/G / NET — One-push selection from Gross weight to Net weight.

3 ZERO — Quickly “zero off” weight on the scale.

4 PRINT — Initiates basic print function.

5 TRAFFIC LIGHT CONTROLS — Complete manual traffic light control at the touch of a key.

6 TARE — Use to accept the displayed weight as the transaction Tare value.

7 IN / OUT — Use to obtain the Net weight of an incoming/outgoing vehicle by capturing its Gross and Tare values.



With Fairbanks' FB6000 Instruments, you don't have to pay for expensive features that are not applicable to your business. Fairbanks has taken the essential instrument functions used in sophisticated, high-traffic vehicle weighing and packaged it into economical, yet attractive steel enclosures perfect for office, industrial or washdown environments.

FB6000 Instruments transmit weight data through a serial or Ethernet TCP/IP connection to a PC for scale software interfacing, or transfer

.csv transaction files directly to a USB flash drive.

FB6000 Instruments are smart enough to identify and match inbound and outbound vehicles, store up to 1000 tare weights, and capture truck identification. They also integrate with all manufacturers' analog scales and popular traffic light controls. These, and many other exciting features, make FB6000 Instruments the perfect economical choice to replace an old or failed analog instrument, or create a new weighing system.

Standard Features

- Bright red, 16-segment, LED display
- Transaction export (CSV) functions
- Gross - Tare - Net weigh mode
- Inbound / Outbound weigh mode
- One programmable prompt
- Front panel traffic control

Accessory Interfaces

ACC 1

Internal Active or Passive
20 mA Interface

ACC 2

High resolution 4-20 mA or
Traffic light interface card

ACC 3

Remote switch controls four internal inputs:
• Zero • Print • Tare • Gross / Net

All three FB6000 enclosure styles feature the interfaces and ports shown on the desktop model.

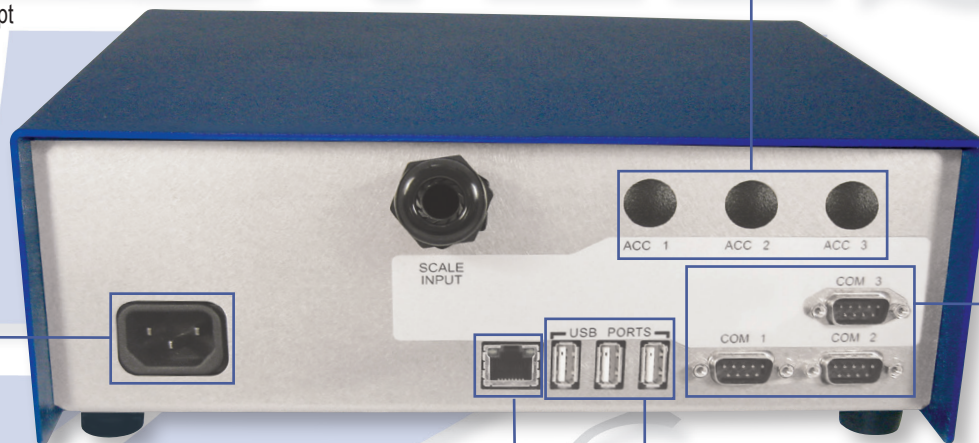

Power port

Serial

Three (3) dedicated RS232C ports for connecting to computers, printers and other serial devices.

Approvals



Ethernet TCP/IP

One (1) Ethernet TCP/IP port for providing continuous weight data and access to the instrument using the web utility.

USB

Three (3) standard USB 2.0 ports are available for connecting a USB keyboard and USB flash drives for data transport.

Modes of Operation

Gross - Tare - Net Mode (GTN)

GTN mode allows the scale operator to process weighments with or without the use of a keyboard-entered Tare or Autotare by simply pressing the PRINT key.

Inbound / Outbound Mode (In/Out)

This mode allows the Operator to weigh a vehicle "In" and temporarily store the transaction using a Loop ID (numeric only). When the vehicle returns to the scale to exit the facility, simply press the "Out" key to recall the Inbound weighment and complete the transaction with Gross, Tare and Net values. In/Out mode supports up to 1,000 stored Tares.

Basic In / Out Mode (One-button weighing)

This Basic In/Out mode is designed for applications in which no calculated NET weight is desired. After entering the scale, a loaded vehicle's weight is captured by pressing the GROSS PRINT button — an empty vehicle is captured by pressing the TARE PRINT button.

FB6000 SERIES

TRUCK SCALE INSTRUMENTS FOR MID-RANGE APPLICATIONS

Weighing Solutions for the World Since 1830

Fairbanks.com

SPECIFICATIONS

Enclosures	Desktop Model - Stainless steel and powder coated steel, NEMA 12 (Analog or Intalogix® load cell interface) Desktop/Wall mount Model - Stainless steel, NEMA 4X (Analog or Intalogix® load cell interface) Panel mount Model - Stainless steel and powder coated steel, NEMA 4X (Analog or Intalogix® load cell interface)
Processor	1 GHz Quad Core
Memory	1 GB
On-board storage	2 GB
Number of scales	1
Display	Bright red, 16-segment, LED with adjustable intensity
Units	lb, kg, ton and tonne
Keypad	Oversized keys: 0-9, Decimal point, Enter, 9 control keys
Loop ID/Truck ID	Up to 15 alphanumeric characters
Load cells	Ten 350 ohm cells, 16 1000 ohm cells
Outputs	Three (3) RS232C ports, Three (3) USB 2.0 ports, One (1) dedicated optically isolated 20mA One (1) RJ45 Ethernet TCP/IP
Remote switch inputs	Zero, Print, Tare, Gross/Net
Power requirements	100 to 130 VAC or 200 to 260 VAC; 50/60 Hz
Clock	Real time clock, 12-hour a.m./p.m., Date (month/day/year)
Displayed characters	0.80" tall
Display resolution	10,000 divisions commercial, 50,000 divisions for non-commercial
Capacity	Programmable to 999,999
Displayed units	4 primary and 4 secondary
Programmable fields	1
Stored tares	1,000
Transaction records	100,000
Humidity	0 to 90% (FB6001, FB6011 models) 0 to 100% (FB6002, FB6012, FB6003, FB6013 models)
Accuracy	Class III/IIIL
Accessories	4-20 mA (16 bit), Traffic light control card, Peripheral devices: Ticket printer, tape printer, remote displays, traffic light, traffic light control box, 105 key QWERTY keyboard, 87 key QWERTY keyboard
Approvals	NTEP CC# 12-099, MC# AM-5878, ETL

DIMENSIONS - DESKTOP - NEMA 12

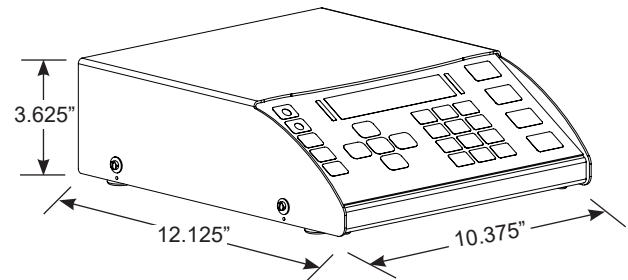

DIMENSIONS - DESKTOP/WALL MOUNT - NEMA 4X

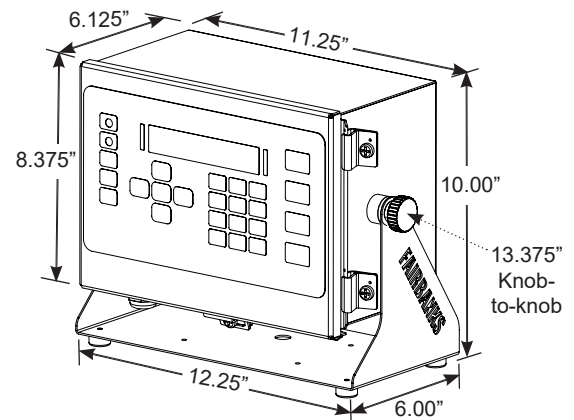

DIMENSIONS - PANEL MOUNT - NEMA 4X

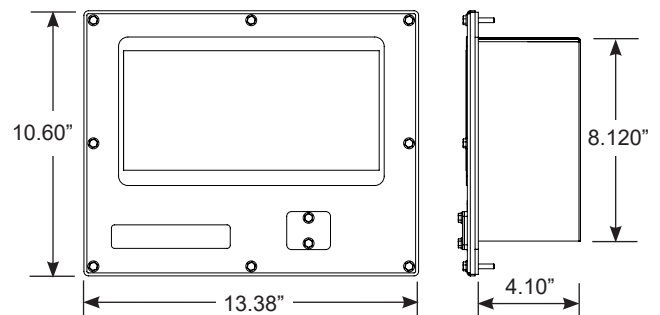

Your Fairbanks Scales Authorized Representative is:

Call toll-free for the representative nearest you:

(800) 451-4107

Call between 8:00 a.m. – 5:00 p.m. Central Time

Corporate Headquarters: 6800 W. 64th Street, Overland Park, Kansas 66202

(816) 471-0231 Internet Address: <http://www.Fairbanks.com>

