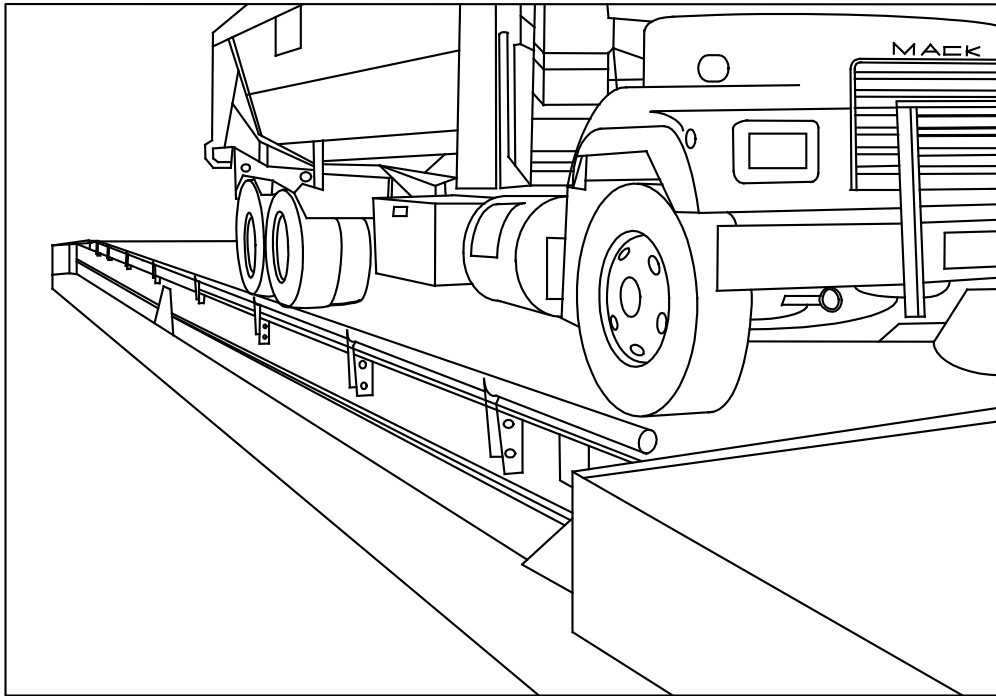




# **Talon Series**

## **Portable Vehicle Scale**





## **Disclaimer**

Every effort has been made to provide complete and accurate information in this manual. However, although this manual may include a specifically identified warranty notice for the product, Fairbanks Scales makes no representations or warranties with respect to the contents of this manual, and reserves the right to make changes to this manual without notice when and as improvements are made.

Fairbanks Scales shall not be liable for any loss, damage, cost of repairs, incidental or consequential damages of any kind, whether or not based on express or implied warranty, contract, negligence, or strict liability arising in connection with the design, development, installation, or use of the scale.

**© Copyright 2021**

This document contains proprietary information protected by copyright. All rights are reserved; no part of this manual may be reproduced, copied, translated or transmitted in any form or by any means without prior written permission of the manufacturer.

---

# Amendment Record

---

## Talon Series

### Portable Vehicle Scale

*Installation Manual*

**Document 51372**

Manufactured by Fairbanks Scales, Inc.

Created	10/2018	
Revision 1	10/2018	Initial release
Revision 2	04/2019	Improved photos
Revision 3	04/2021	Updated: Required tools

---

# Table of Contents

---

<b>SECTION 1: GENERAL INFORMATION.....</b>	<b>6</b>
<b>1.1. Introduction .....</b>	<b>6</b>
<b>1.2. Description .....</b>	<b>6</b>
<b>1.3. Specifications.....</b>	<b>7</b>
<b>SECTION 2: INSTALLATION .....</b>	<b>8</b>
<b>2.1. Checklist of Tools, Equipment, and Materials .....</b>	<b>9</b>
<b>2.2. Installing a Concrete Pier .....</b>	<b>10</b>
2.2.1. <i>Site Preparation – All foundation types .....</i>	<i>10</i>
2.2.2. <i>Steps to Installing the Pier .....</i>	<i>10</i>
<b>2.3. Installation and Relocation Procedures.....</b>	<b>11</b>
2.3.1. <i>3 MODULE PV SCALE - Installation for 60' &amp; 70' scales with three (3) modules .</i>	<i>11</i>
2.3.2. <i>How to Install Approaches and Ramps:.....</i>	<i>17</i>
2.3.3. <i>To Prepare Scale for Relocation.....</i>	<i>19</i>
2.3.4. <i>4 MODULE PV SCALE -Installation for 80' scales with four (4) modules .....</i>	<i>22</i>
<b>SECTION 3: ELECTRICAL INSTALLATION .....</b>	<b>24</b>
<b>3.1. Description .....</b>	<b>24</b>
<b>3.2. Installation .....</b>	<b>24</b>
3.2.1. <i>Interconnection Wiring.....</i>	<i>25</i>
3.2.2. <i>Dip (Address) Switch Setup, SSCs.....</i>	<i>25</i>
3.2.3. <i>Cell Numbering.....</i>	<i>27</i>
3.2.4. <i>SSC Connections .....</i>	<i>27</i>
3.2.5. <i>Grounding .....</i>	<i>28</i>
3.2.6. <i>Indicator to Pit Power Supply Cable Connection.....</i>	<i>29</i>
<b>SECTION 4: CALIBRATION.....</b>	<b>31</b>
<b>4.1. Preliminary Checks.....</b>	<b>31</b>
<b>4.2. Repeatability and Return-to-Zero performance tests .....</b>	<b>31</b>
<b>4.3. Section Test and Adjustments.....</b>	<b>31</b>
<b>4.4. Digital indicator span calibration .....</b>	<b>31</b>
<b>SECTION 5: SERVICE &amp; MAINTENANCE.....</b>	<b>32</b>
<b>5.1. Maintenance Inspections .....</b>	<b>32</b>
<b>5.2. Load cell replacement .....</b>	<b>32</b>
<b>5.3. SSC board replacement.....</b>	<b>33</b>
<b>5.4. PPS board replacement.....</b>	<b>33</b>
<b>SECTION 6: PARTS .....</b>	<b>34</b>
<b>6.1. Scale Parts List .....</b>	<b>34</b>



<b>6.2. Load Cells and Load Cell Hardware .....</b>	<b>34</b>
<b>6.3. Spare Parts .....</b>	<b>35</b>
6.3.1. <i>Recommended Spare Parts .....</i>	35
6.3.2. <i>Startup / Commissioning Spart Parts.....</i>	35
6.3.3. <i>2-Year Spare Parts List .....</i>	35
<b>APPENDIX I: WIRING .....</b>	<b>36</b>

---

# Section 1: General Information

---

## 1.1. INTRODUCTION

The **Talon Portable Vehicle Scale** is a uniquely designed truck scale, combining the proven reliability of a hermetically sealed load cell system with the added benefit of an above grade, low profile, portable, steel deck design scale. The Talon Series PV scale uses a **Rocker Column Load Cell System** combined with **Intalogix™ Technology**.

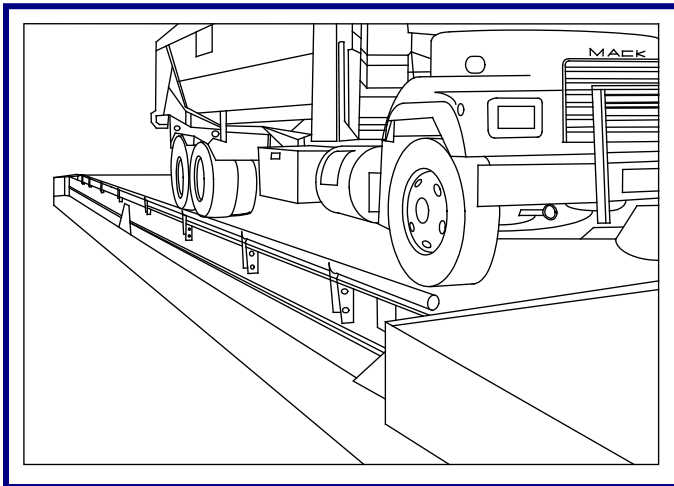
## 1.2. DESCRIPTION

The Talon Weighbridge consists of twenty and twenty-three foot (20' & 23') factory assembled steel deck modules.

- Each module bolts to the adjoining module.
- With the scale installed completely above ground, the load cell system, suspension components and weighbridge are not subjected to the harsh, corrosive environments found in a scale pit.

Rocker Column Load Cell Systems are hermetically sealed cells, constructed entirely from stainless steel.

- A stainless steel sheathing protects the load cell cable.
- Intalogix™ Technology offers the customer outstanding resolution, surge voltage protection, and built-in diagnostics.



### **1.3. SPECIFICATIONS**

<b>CLC:</b>	90,000 lbs.
<b>Capacity:</b>	240,000 lbs. for a 4 section scale 300,000 lbs. for a 5 section scale
<b>Load cell data:</b>	
<b>Capacity:</b>	66,000 lbs.
<b>Type:</b>	Rocker column
<b>Environmental:</b>	Stainless steel, hermetically sealed
<b>Bridge resistance:</b>	1000 ohm
<b>Output:</b>	2.4 mV/V
<b>Construction:</b>	Welded structural steel I-beam
<b>Module Design:</b>	Orthotropic
<b>Module understructure:</b>	Open bottom
<b>Lengths:</b>	60', 70' and 80'.
<b>Width:</b>	10'
<b>Deck plate thickness:</b>	1/4"
<b>Material:</b>	ASTM A-36 steel
<b>Soil bearing:</b>	Recommended 3,000 psf (per square foot)
<b>NTEP CC number:</b>	96-089

---

## Section 2: Installation

---

The **Talon Portable Vehicle Scale** can be set up almost anywhere it's needed.

- The soil bearing under the scale sub-frame must be firm and unyielding. Recommendation of 3000 p.s.f.
- Concrete piers are best at anchoring a solid, level base for the sub-frame. However, the sub-frame may be set on firm level ground, a leveled gravel area or be placed on heavy wood supports.

The scale is **shipped fully assembled** with stands, suspension hardware, with load cells installed.

---

**NOTE:** *Always CALL BEFORE YOU DIG.*

**1-888-258-0808**

---

Standard practice for onsite construction of earthen ramps for Portable Vehicle scales uses compacted graduated limestone fill, or caliche fill (provided by others). Either of these choices typically will provide a solid non-yielding base if installed and compacted correctly. Concrete berms along the sides of the ramps may be used to keep the material from spreading out during the compacting process, but this is typically not necessary.



## 2.1. CHECKLIST OF TOOLS, EQUIPMENT, AND MATERIALS

*Listed below are the approximate maximum weights of scale modules. This applies to all models.*

- Steel Modules – 4 tons
- Field Pour Modules – 3 tons
  - With Concrete – 12.5 to 15 tons (+/- 5%)

*The following lists all the needs of a standard installation.*

- Certified Prints
- Mobile Crane of sufficient capacity to safely lift and place the weigh bridge modules.\*
- Four (4) Lifting Chains/Cables with Hooks\*
  - Equal in length (20 ft.) to safely lift and install the modules.\*
- Machinists Levels (Starrett # 134 & 132-6)
- Hand Tools:
  - Wrenches and Sockets
    - 15/16"      ▪ 1 1/8"      ▪ 1 1/4"
    - 1 1/2"      ▪ 1 11/16"
- Hammer Drill with 5/8" Bit, 24" long
- Hydraulic Jacks with substantially higher capacities than weight of modules.
- Steel modules    10 ton hydraulic jacks (2)
- Field pour Modules    30 ton hydraulic jacks (2)
  - 96496 30 ton jacks
  - 96497 Hand pump
  - 96498 Hose, 6'
- 100' Steel Tape Measure, String-line and / or chalk-line
- Pry-bars
- Grease and anti-seize (*see note below*)

---

**NOTE: Grease** for load cell cups: equal to *Super Lube White Grease* (food grade)

---

- Load Cell Locating Tools (one per load cell)
  - **157069** for 4 11/16" cell
- Timbers for Field Pour Shoring, **4" x 4" x 12'**

## 2.2. INSTALLING A CONCRETE PIER

### 2.2.1. Site Preparation – All foundation types

1. Help the customer select a site which allows easy access to and from the scale, ensuring enough area for straight and level approaches, and to meet all state and local Weights and Measures regulations.
  - The site needs good drainage away from the scale, elevated enough so the surrounding areas ***drain away from the scale site***.
  - Obtain all the necessary permits and licenses prior to beginning construction.
2. Using a transit, sight in and mark with stakes the area where the placement is to occur, and where supports, forms, or concrete are to be built.
  - **When** constructing forms, make sure they are plumb, square, and level.
  - Place and compact gravel into the base of the forms, if necessary.

### 2.2.2. Steps to Installing the Pier

3. Cut and position rebar into the form exactly as the schedule details it in the Fairbanks certified foundation prints.
4. The scale is designed so the sub-frame is anchored to the foundation, using expansion anchors which are inserted into the concrete after it has cured.
  - Expansion anchors are recommended because of the flexibility allowed in final positioning of the scale.
  - Use sub-frames for anchor locations.
5. Pour concrete, using a mix to yield a minimum 4000 psi.
6. Vibrate the concrete into position to ensure consistency.
  - All concrete work ***MUST*** conform to standards set forth by the **American Concrete Institute Code**.
  - Allow concrete to cure several days before erecting the scale.
7. Remove the forms and backfill for proper drainage.
  - A slope away from the scale is recommended.

***Allow concrete to cure for **twenty-eight (28) days**, or until a test cylinder indicates the concrete has reached its design strength before allowing traffic on the scale.***

## 2.3. INSTALLATION AND RELOCATION PROCEDURES

Talon PV Scales are available in 60', 70', and 80' lengths. This manual was created to cover all the potential methods for installing a Fairbanks PV Scale. Your installation procedure will vary slightly depending on the number of modules in your scale. The following will provide guidance for your particular installation.

C A U T I O N

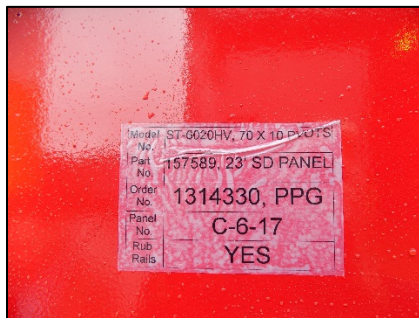
**Module Assemblies are heavy and awkward to handle.**

**Exercise extreme care when lifting a module assembly so as to avoid personal bodily harm or damage to any equipment.**

**When lifting the modules, ensure that the lifting chains are equally loaded, secure, and that an angle of greater than 30 degrees is maintained.**

### 2.3.1. 3 MODULE PV SCALE - Installation for 60' & 70' scales with three (3) modules

1. Identify the center module. The center module will have load blocks at each end weldment. It is also the only module that has the base frame spreader pipes pre-installed at the factory. There is also a decal identifying the center module located on one of the end weldments. See *Figure 1*.



**Figure 1**



**Figure 2**

### **2.3.1. 3 MODULE PV SCALE - Installation for 60' & 70' scales with three (3) modules, continued**

2. Identify the appropriate location for the center module allowing adequate clearance for the end modules that will be installed to complete the scale. **BEFORE YOU LIFT!** Safely rig the scale module with the provided lifting points on the side of the scale. **DO NOT LIFT BY SUBFRAME or RUBRAIL**, the module and sub-frames are secured together with shipping brackets. Lift and set the center module in the appropriate position. Be sure that your selected position leaves enough clearance for the complete scale installation.

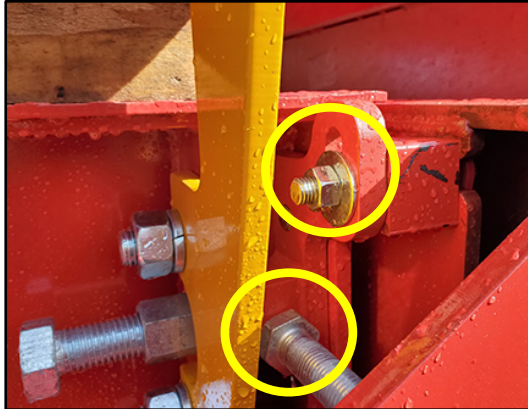


**Figure 3**

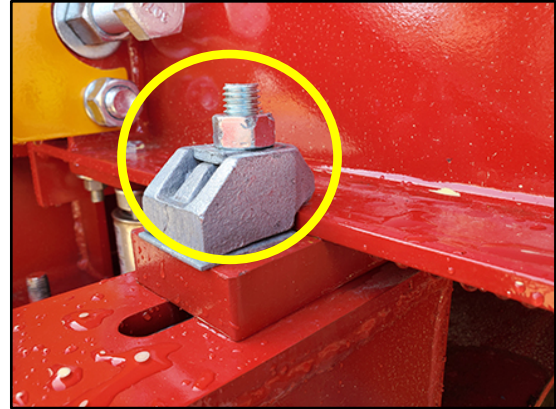
3. Identify the left end module. The end modules will have load blocks on one end weldment and a checking assembly at the other. The end modules will also have a decal identifying them as either right or left end modules.
4. Verify that the side checking bolts are tight against the sides of the scale to prevent movement. Be sure the end checking is tight against the end of the bulkhead. Both side and lateral checking must be tight against the scale to prevent movement.

**2.3.1. 3 MODULE PV SCALE - Installation for 60' & 70' scales with three (3) modules, continued**

5. Verify that shipping clamps at the interface points between the weighbridge and the pedestal frame are all tight. See Figures 4 and 5.

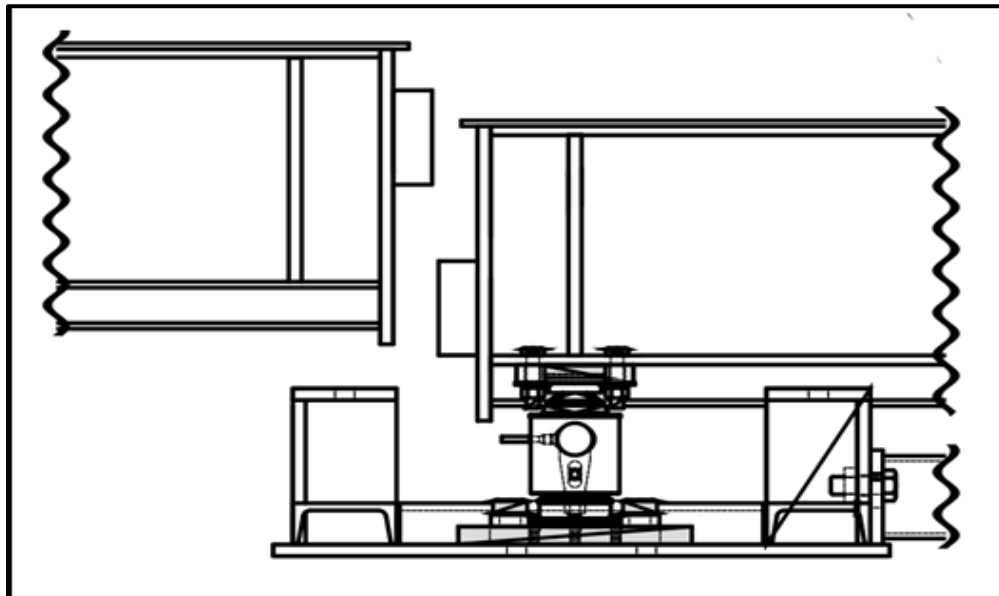


**Figure 4**



**Figure 5**

6. Once identified, prepare to lift. **BEFORE YOU LIFT!** Safely rig the scale module with the provided lifting points on the side of the scale. **DO NOT LIFT BY SUBFRAME or RUBRAIL**, the module and sub-frames are secured together with shipping brackets. Place the left end module next to the center module such that the load blocks of the left end module is bearing down on the load blocks of the center module. Be sure the two modules are square with each other and aligned on the center line of the scale. See Figure 6.

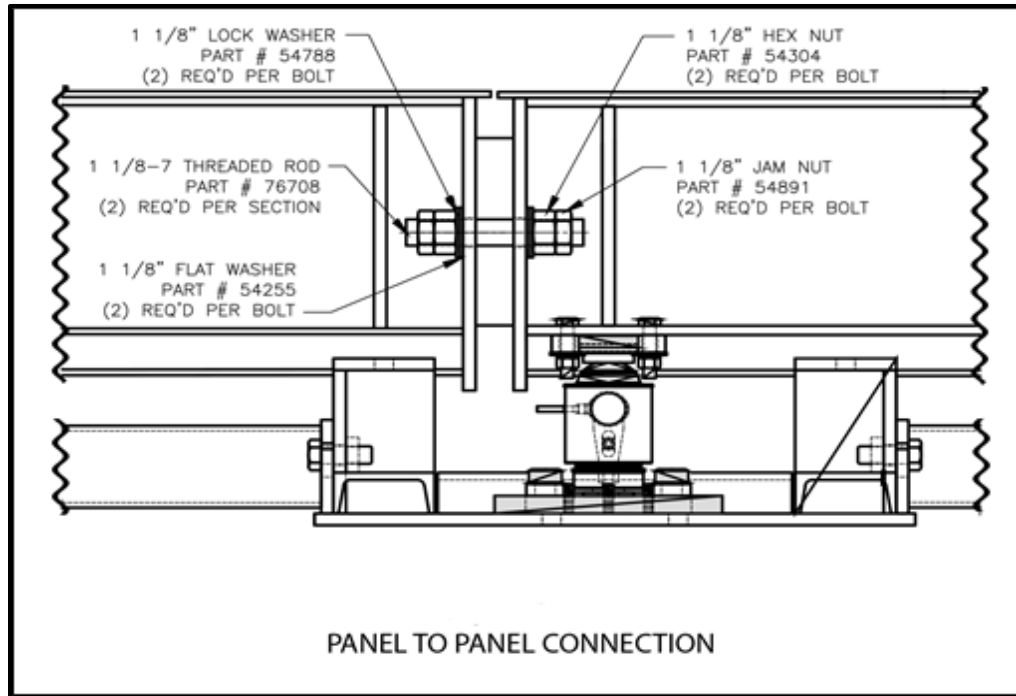


**Figure 6**



**2.3.1. 3 MODULE PV SCALE - Installation for 60' & 70' scales with three (3) modules, continued**

7. Install module connection bolts. Insert the 1 1/8" – 7 threaded rod into the module connection gussets and secure with the flat washer, lock washer, hex nut and jam nut as indicated. See Figure 7.

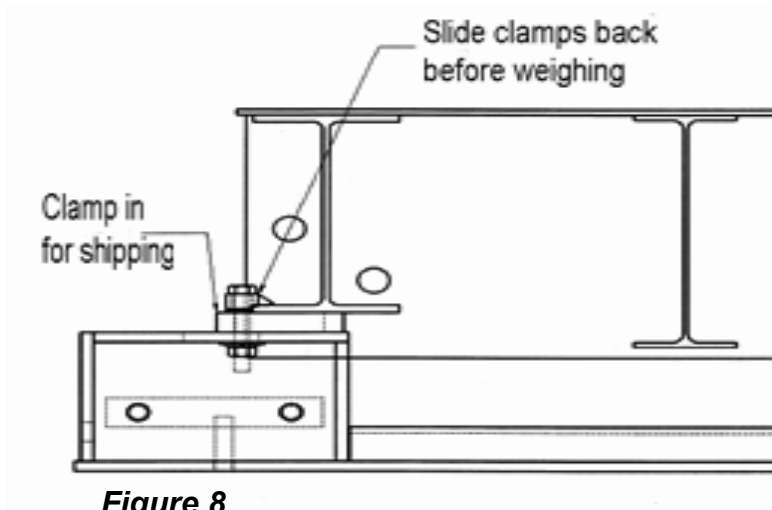


**Figure 7**

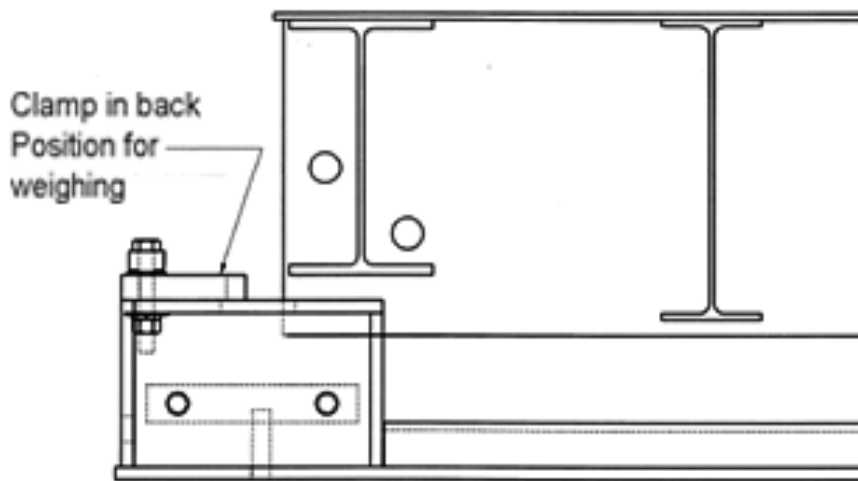
8. Prepare to place the right end module. **BEFORE YOU LIFT!** Safely rig the scale module with the provided lifting points on the side of the scale. **DO NOT LIFT BY SUBFRAME or RUBRAIL**, the module and subframes are secured together with shipping brackets. Place the remaining right end module next to the center module such that the load blocks of the right end module are bearing down on the load blocks of the center module. Be sure the two modules are square with each other and aligned on the center line of the scale.

**2.3.1. 3 MODULE PV SCALE - Installation for 60' & 70' scales with three (3) modules, continued**

9. After the two end modules are set, loosen the clamp brackets that secured the pedestal to the weighbridge. Slide the clamps and plates out of the weight into the storage position but leave attached to the pedestal frame. See *Figures 8 & 9*



**Figure 8**

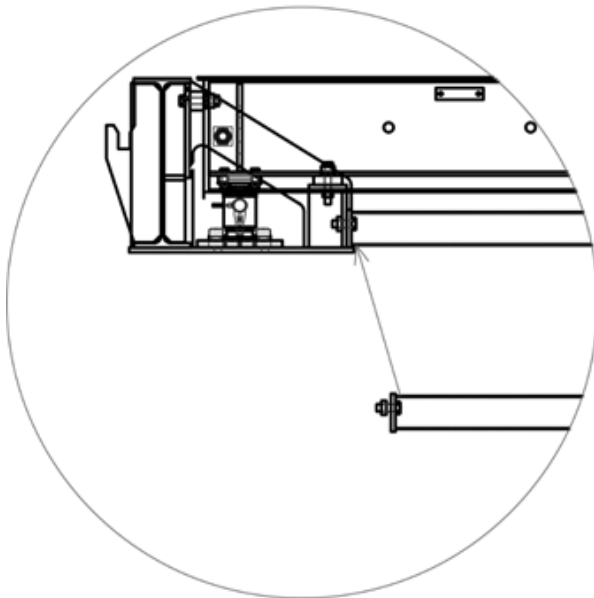


**Figure 9**

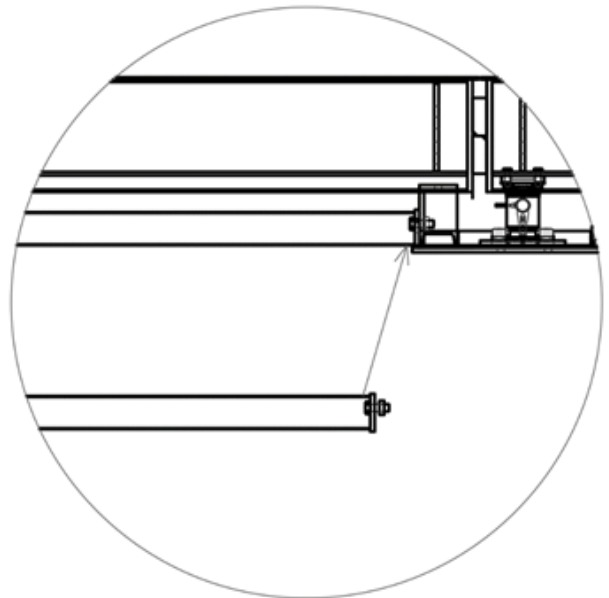
### **2.3.1. 3 MODULE PV SCALE - Installation for 60' & 70' scales with three (3) modules, continued**

At this point in the installation, the modules are fastened together and disengaged from the pedestal shipping clamps. The scale is now a live deck.

1. The next step involves securing the provided pipe space weldments between each end module and the center module. Each end module will require pipe spacers installed on either side of the module. *See Figures 10 & 11*



**Figure 10**



**Figure 11**

2. Identify the pipe spacer weldments and the pedestal mounting holes anti-slide brackets and anti-slide bracket mounting holes located at the sectional pedestals.
3. Each pipe spacer weldment is secured by two bolts and nuts at the end pedestal and two bolts and nuts at the center pedestal. Secure four (4) pipe spacer weldments with provided hardware. *See Figures 12 and 13.*



### **2.3.1. 3 MODULE PV SCALE - Installation for 60' & 70' scales with three (3) modules, continued**



**Figure 12**



**Figure 13**

4. Verify load cells are plumb.
5. If installed on concrete base or piers, you are ready to anchor. Check once again that the scale is correctly aligned; the modules are square and in-line with each other. Once it is determined that the scale is square, secure the pedestal sub-frame to the concrete base, or piers with anchors.
6. The final step is to install the provided grounding rods.

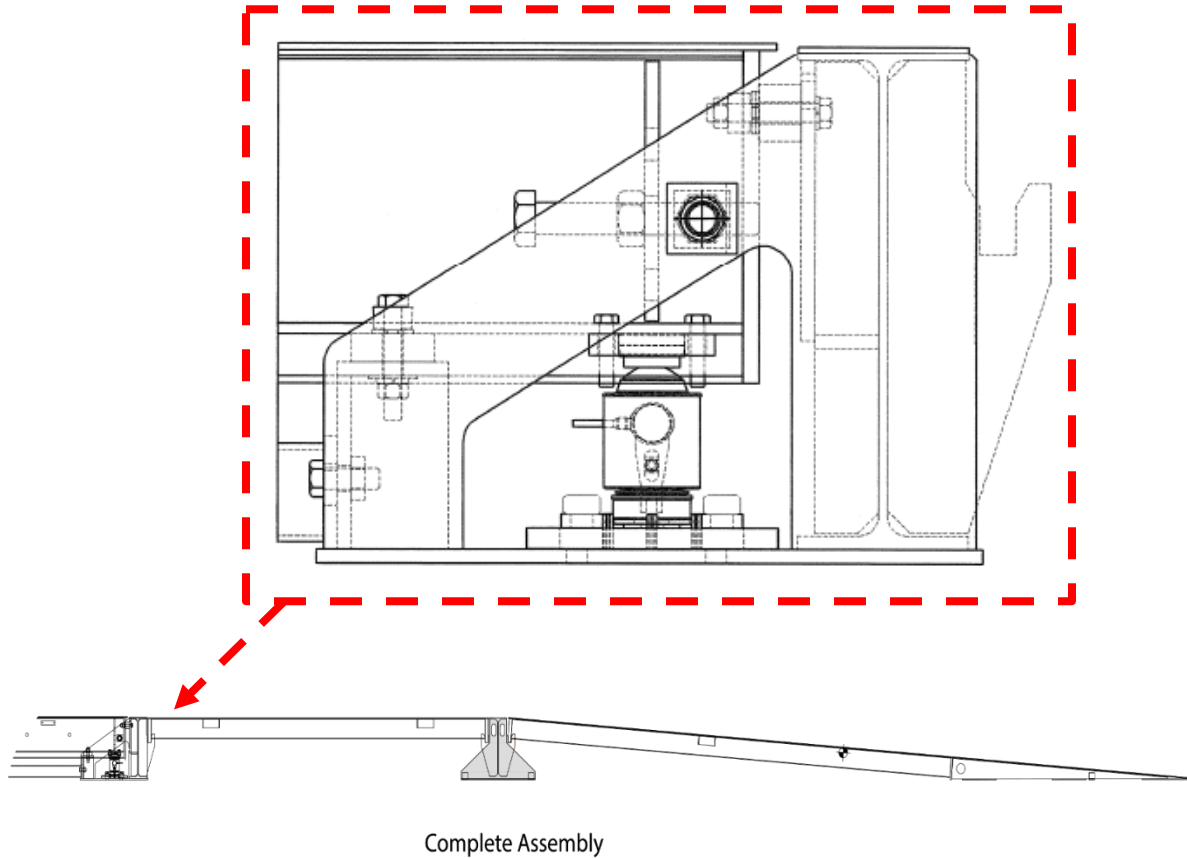
### **2.3.2. How to Install Approaches and Ramps:**

#### ***Fairbanks Ramps and Approaches Kits***

If your installation required Fairbanks ramps and approaches kit, please follow these instructions for assembly. If you are using ramps and approaches, the approaches must be set before the ramps.

1. Ramps and approaches cannot be installed until the scale is set, assembled, and secure.
2. Place the approach bulkhead that will support the approach approximately 9' 6" from the pedestal bulkhead of the scale. This distance is measured from the top flange of the pedestal bulkhead to the top flange of the approach bulkhead (inside to inside). This is an approximate distance; you may need to adjust slightly during the assembly.
3. To attach approaches, rig lifting equipment to the provided lifting points and lift the approach and set the approach end bar into the scale's bulkhead saddle first.

### 2.3.2. How to Install Approaches and Ramps, Continued



**Figure 14**

4. Once the approach is seated in the scale bulkhead, you can lower the approach to connect with the approach bulkhead. You may need to adjust the approach bulkhead such that the approach pins will slide below the top flange and into the provided saddle.
5. The approaches are secured to the bulkhead and pedestal with brackets attached with bolts in the pre-tapped holes.

### 2.3.2. How to Install Approaches and Ramps, Continued

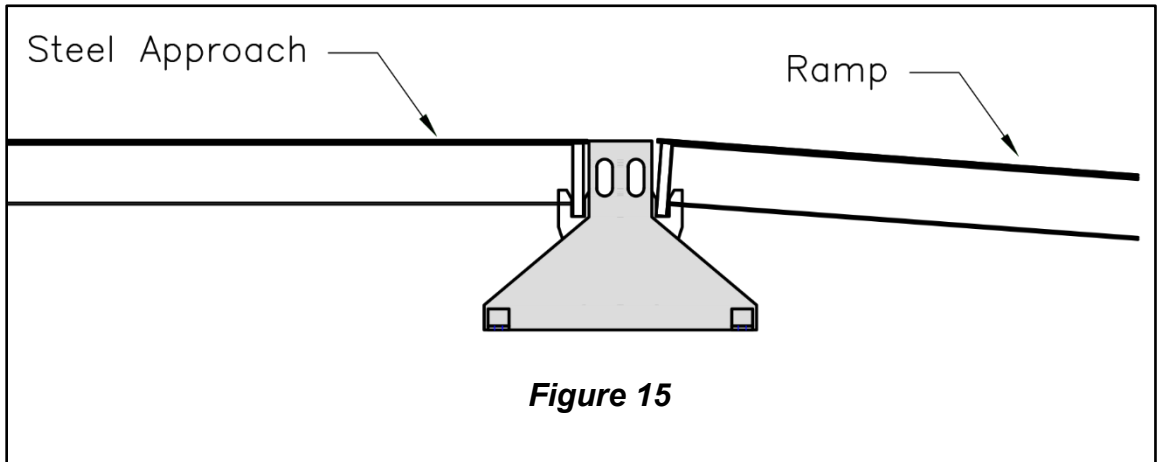


Figure 15

#### RAMPS

6. Set the ramps end plate into the approach bulkhead's saddle. See *Figure 15* in step 5.
7. The ramps are secured to the pedestal (or bulkhead) using the same brackets as the approaches. Attach to the bulkhead or pedestal with provided brackets/bolts. See *Figure 16*.

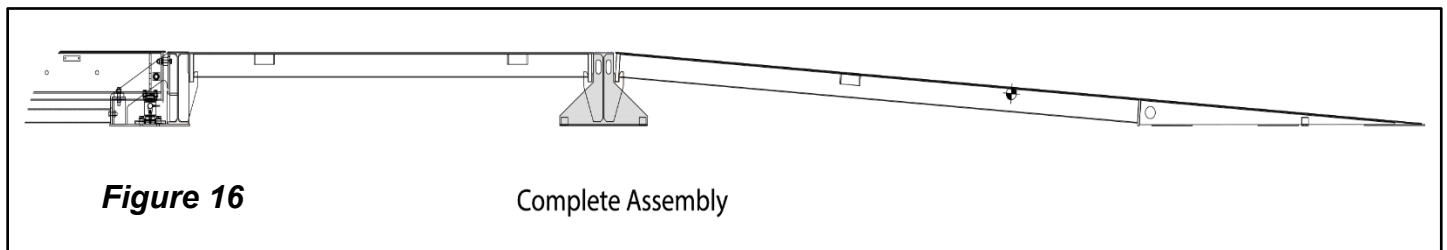


Figure 16

Complete Assembly

### 2.3.3. To Prepare Scale for Relocation

**Note: The sequence will be REVERSED**

1. Remove ramps first (if applicable). Disconnect connection bolts, washers, and spacers connecting the ramps to the approach bulkhead. Rig lifting equipment to the provided lifting points, lift ramps, and set aside.
2. Remove approaches (if applicable). Disconnect connection bolts, washers, and spacers connecting the approach to the approach and scale bulkhead. Rig lifting equipment to the provided lifting points, lift approaches, and set aside.
3. Rig lifting equipment to the provided lifting points on approach bulkhead, lift bulkheads and set aside. Refer to image in *Step 3*.

4. Disconnect scale from grounding system.
5. If anchored, remove anchors.
6. Disconnect four (4) pipe spacer weldments from the two (2) end modules and remove from the pedestals. **DO NOT REMOVE** the center module pipe spacer weldments.

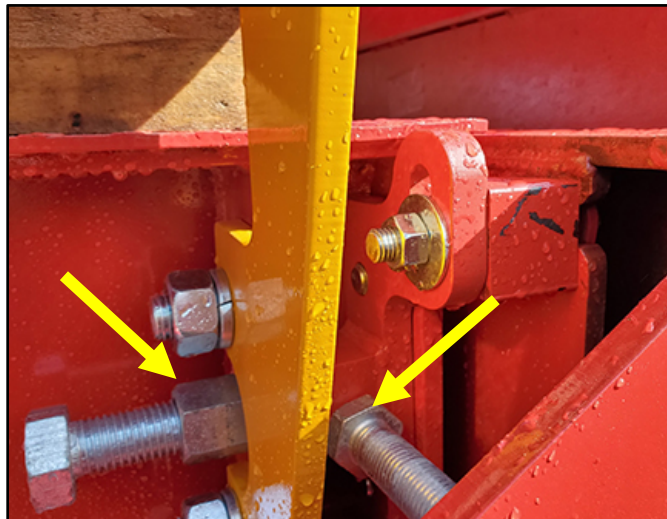


**Figure 17**



**Figure 18**

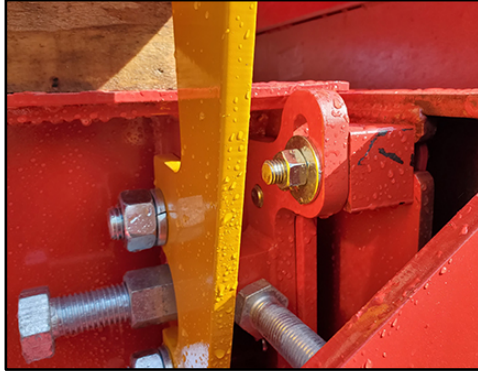
7. Tighten side and bulkhead checking bolts so they secure the scale and prevent any movement. *See Figure 19*



**Figure 19**

**2.3.2. How to Install Approaches and Ramps, Continued**

8. Secure shipping clamps on all sides (8 per module.) See *Figures 20 & 21.*

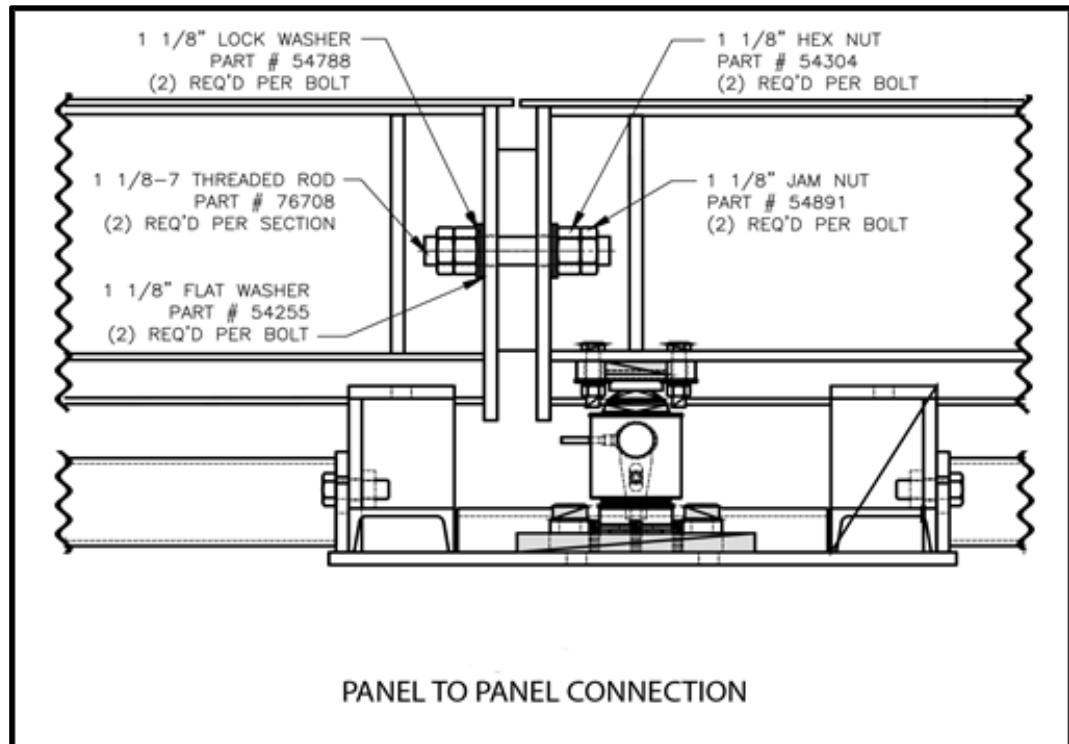


**Figure 20**



**Figure 21**

9. Disconnect module connection. Remove jam nut, hex nut, and washers from 1 1/8" – 7 threaded rods. Remove threaded rod. Refer to *Figure 22.*



**Figure 22**



### 2.3.2. How to Install Approaches and Ramps, Continued

10. Prepare to disassemble modules for relocation. Begin with the right end module. **BEFORE YOU LIFT!** Safely rig the scale module with the provided lifting points on the side of the scale. **DO NOT LIFT BY SUBFRAME or RUBRAILS**, the module and sub-frames should be secured together with shipping brackets installed. Lift the right end module and set aside.
11. Next, disassemble the left end module. **BEFORE YOU LIFT!** Safely rig the scale module with the provided lifting points on the side of the scale. **DO NOT LIFT BY SUBFRAME or RUBRAILS**, the module and sub-frames should be secured together with shipping brackets installed. Lift the left end module and set aside.
12. The center module will remain. **BEFORE YOU LIFT!** Safely rig the scale module with the provided lifting points on the side of the scale. **DO NOT LIFT BY SUBFRAME or RUBRAILS**, the module and sub-frames should be secured together with shipping brackets installed. Lift the center module and relocate to new position and begin installation steps again for new location.

### 2.3.4. 4 MODULE PV SCALE -Installation for 80' scales with four (4) modules

1. The 80' scale will be installed using the same procedures outlined in the 3-module PV installation section. The difference in procedure is in setting the second interior panel in addition to the outer panels.
2. Identify the interior/center module. The center module will have load blocks at each end weldment. It is also the only module that has base frame spreader pipes pre-installed at the factory. There is also a decal identifying the center module located on one of the end weldments.



Figure 23

### **2.3.3. 4 MODULE PV SCALE -Installation for 80' scales with four (4) modules, Continued**



**Figure 24**

3. The second interior module will be installed in the same procedure as the two-outer panel detailed in section 2.1.1. of the 3 module PV scale installation procedure.
4. Follow all the other steps in the 3 module PV installation procedure to complete installation of scale and ramps/approaches as appropriate.

---

# Section 3: Electrical Installation

---

## 3.1. DESCRIPTION

The Talon PV Scale is designed to be used with **Intalogix™ Systems**, which utilize **Smart Sectional Controllers (SSC)** and **Pit Power Supplies (PPS)** for load cell excitation and signal processing.

Most applications use one (1) SSC per section, and one (1) PPS for the entire platform.

- This applies until the number and resistance of the cells require a second pit power supply.

**SSC boxes have four (4) terminals.**

- Two (2) terminals are used for load cells and two (2) for interfacing to other SSC boxes or terminating to a pit power supply.
- All cell/section/scale adjustments are made using the **Intalogix™ System Instrument**.

## 3.2. INSTALLATION

### Boxes

The box has mounting brackets which allow mounting to adapters located inside each load cell access hole of the Talon modules.

### Wiring

Cable used in all wiring must be a minimum of 18 AWG. Use cable 17204 or 17246. Use appropriate service manual for the indicator being installed or refer to the Appendix for typical wiring information.

### Smart Sectional Controller (SSC)

Wire cells into each section's sectional controller per the appropriate service manual. Refer to the Appendix for typical wiring information.

### Load Cell Wiring Designations

Color	Description
Blue	(-) Excitation
Red	(+) Excitation
Gray	(-) Signal
Green	(+) Signal



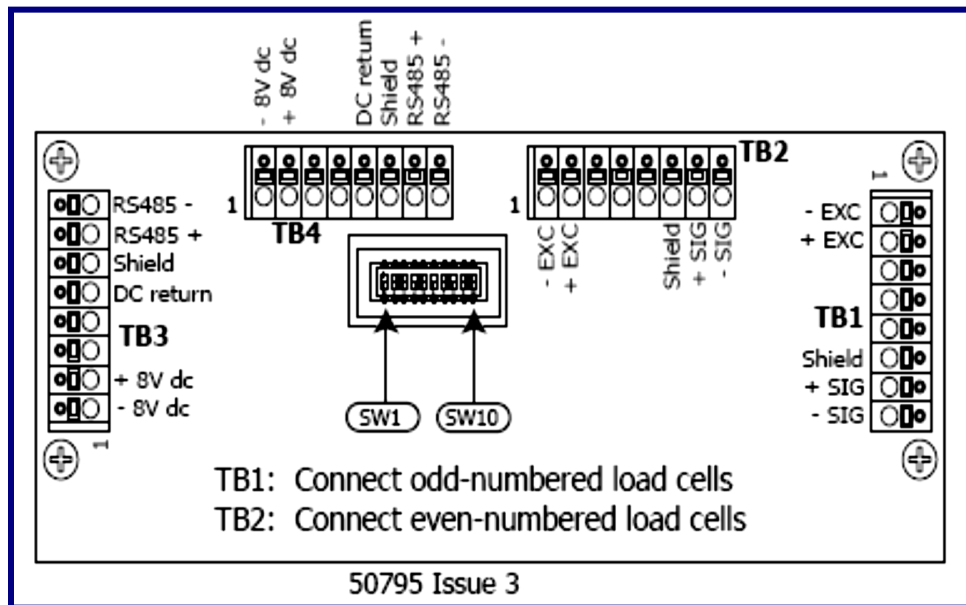
### 3.2.1. Interconnection Wiring

TB3 or TB4 in SSC	Function	17246 Cable
1	(-) 8.0 volts	Black
2	(+) 8.0 volts	Green
5	DC Return	Blue
6	Shield	Shield
7	RS-485 (+)	White
8	RS-485 (-)	Red

**NOTE:** On the **17246 Cable** daisy-chain connections, the **Orange** wire is **NOT USED**.

### 3.2.2. Dip (Address) Switch Setup, SSCs

- In each of the SSC boxes, there is a ten (10) position dip switch labeled **S1**.
  - This switch is used to identify the section in a binary code.
- The switches must be set properly for the scale to operate.



**NOTE:** Switches 1, 2, 3, 4, are **always OFF**. **Leave these switch settings alone.**

**SW 1 position 5 setting**

**OFF = 350 Ω load cells**

**ON = 700/1000 Ω load cells**

### 3.2.2 Dip (Address) Switch Setup, SSCs, Continued

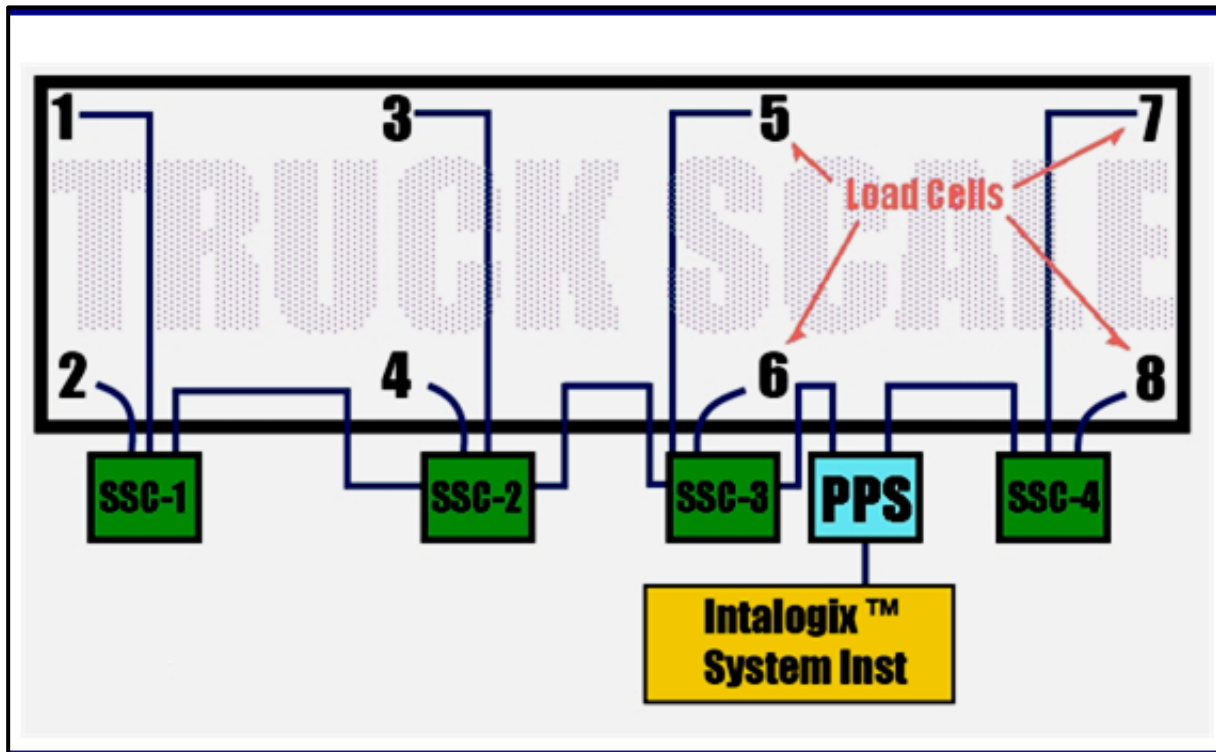
- Switches **6 thru 10** set the Section [Address] Numbers.
- Set the Section Number according to the following chart.
- Each SSC Box will have a unique Section Number entered on the dip switches.

Section Number	Switch Settings				
	6	7	8	9	10
Section 1	On	Off	Off	Off	Off
Section 2	Off	On	Off	Off	Off
Section 3	On	On	Off	Off	Off
Section 4	Off	Off	On	Off	Off
Section 5	On	Off	On	Off	Off
Section 6	Off	On	On	Off	Off
Section 7	On	On	On	Off	Off
Section 8	Off	Off	Off	On	Off
Section 9	On	Off	Off	On	Off
Section 10	Off	On	Off	On	Off
Section 11	On	On	Off	On	Off
Section 12	Off	Off	On	On	Off
Section 13	On	Off	On	On	Off
Section 14	Off	On	On	On	Off
Section 15	On	On	On	On	Off
Section 16	Off	Off	Off	Off	On

### 3.2.3. Cell Numbering

- Intalogix™ Technology installations use a specific numbering system for load cells because of digital addressing of the SSCs.
- With respect to the following starting position, face the platform where the indicator is located.
- The cell at the **upper-left** (far side) of the platform is **Cell One (1)**.
- The cell positions along the **far side** have **odd cell numbers**.
- The **near side locations** have **even cell numbers**.

Above is an example of a four (4) section cell numberings using SSCs.



### 3.2.4. SSC Connections

Each SSC has connections for two (2) incoming load cells, labeled **TB1** and **TB2**.

- The **odd** numbered cell goes to **TB1**.
- The **even** numbered cell goes to **TB2**.

### 3.2.5. Grounding

Intalogix™ Technology systems must have **two (2) ground rods** in the pit for proper connection.

- Pit power supplies one ground for the **weighbridge** and connects the other to the **sectional controller**.
- For accurate operation and protection against damage from lightning strikes, all of the components of the system must be properly grounded.

Use the following guidelines to correctly ground the system:

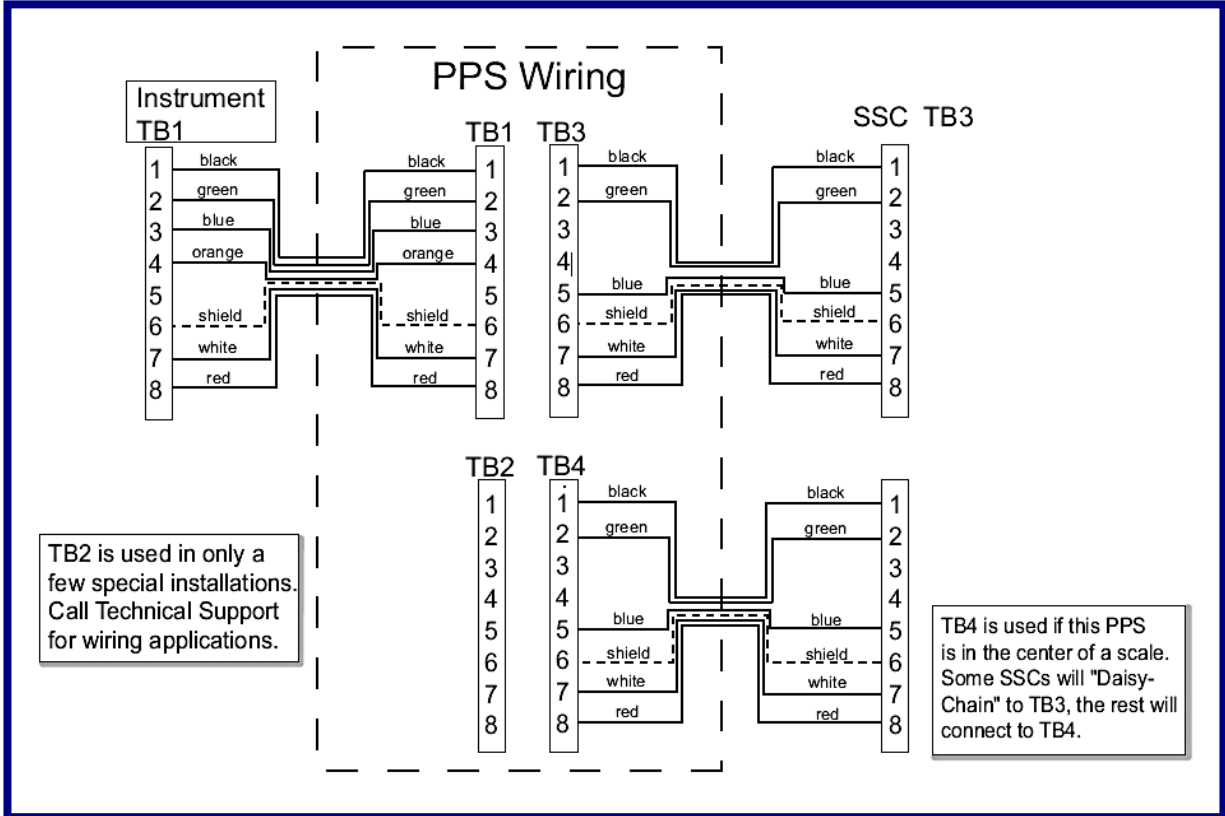
- Use **8 AWG** or larger wire, or **braided ground straps**.
- All ground connections should be **two feet (2')**, or as short as possible.
- The SSCs and PPSs housing attaches in a clean electrical connection **to the platform frame**. The platform frame is then connected to a pit ground rod.
- The insulated **WHITE WIRE** from the PPS connects directly to the separate ground rod **and not to the same rod as the weighbridge**.
- The **117 VAC SVP Unit** connects to a known good ground at the instrument location.
  - Use a voltmeter to test the electrical power source available.
  - The **Neutral-to-Ground** voltage level must be **0.2 VAC or less**.
  - If unsure, or if the testing reveals higher than 0.2 VAC, install a separate ground rod at the **SVP location**, connecting it with braided cable or 8 AWG wire

**C A U T I O N**

**Proper grounding is REQUIRED**  
so the Surge Voltage Protection (SVP) adequately shields the  
scale from lightning and other electrical interferences!

### 3.2.6. Indicator to Pit Power Supply Cable Connection

Prepare the cable ends in the standard manner. Use the appropriate manual for wiring the sectional controllers and power supplies. Connect the indicator interface cable to the instrument in the scale house as shown in the service manual.



Connect the **PPS to an SSC** (#1 or any SSC).

- Feed a cable from **SSC #1 TB3** through the bushing for in the **PPS for TB3**.

Connect the wires as shown in this chart.

TB3 SSC#1	TB3 PPS	17246 Cable	Description
1	1	Black	(-) 8.0 volts
2	2	Green	(+) 8.0 volts
5	5	Blue	DC Return
6	6	Shield	Shield
7	7	White	RS-485 (+)
8	8	Red	RS-485 (-)

**3.2.6 Indicator to Pit Power Supply Cable Connection, Continued**

- Wire the PPS to the Instrument.
  - Run the **Home-Run Cable** from the **PPS – TB1** to the **Instrument's TB1**.
  - **Shields** are used for **DC Return** and **MUST BE CONNECTED**.

**Connect the wires as shown in this chart.**

<b>TB1 PPS</b>	<b>TB1 Inst</b>	<b>17246 Cable</b>	<b>Description</b>
1	1	Black	28 volts, AC
2	2	Green	AC Return
3	3	Blue	20 Volts, DC
4	4	Orange	Enable
6	6	Shield	Shield/DC Return
7	7	White	Transmit
8	8	Red	Receive

---

## Section 4: Calibration

---

### 4.1. PRELIMINARY CHECKS

- Seat the suspension components. Drive the test truck across the scale stopping and starting several times across the scale. Repeat this procedure at least three times to assure that all parts are properly seated.
- Refer to the appropriate technical manual for the particular Intalogix™ Technology Indicator for the setup and calibration procedures.

### 4.2. REPEATABILITY AND RETURN-TO-ZERO PERFORMANCE TESTS

1. **Position the test truck** in the center of the Weighbridge.
2. Note the weight reading.
3. Pull the truck off the scale and note the **Return-to-Zero**.
4. **Repeat this procedure** at least three times to assure consistency.
5. If the scale does not repeat the readings (within tolerance), check for mechanical obstructions or binds.
  - Check the scale thoroughly for proper assembly.
  - Check to see the load cells are properly aligned, level and the load is equally distributed on each load cell.
  - Add or remove shims as required to improve deadload distribution.

### 4.3. SECTION TEST AND ADJUSTMENTS

1. Test the section by centering the test load over each section.
  - A weight cart, block weights, rear axles of the test truck.
2. Note the weight indication of each section.
  - Adjusted each sections so the weight indications match within the tolerances set forth by the **National Institute of Standards and Technology's Handbook H-44**.
3. Trim the sections by placing the test load over each section, and then adjusting it as described in the appropriate Intalogix™ instrument service manual.

### 4.4. DIGITAL INDICATOR SPAN CALIBRATION

- Perform the span adjustments, following the appropriate Intalogix™ Instrument service manual.

---

## Section 5: Service & Maintenance

---

### 5.1. MAINTENANCE INSPECTIONS

- Ensure that the system is maintaining proper ground connections.
- Check module-to-module bolts for tightness.
- Check that the frame has not shifted, and that all bolts are secure.
- Check for movement or washout under any temporary pier structures.
- Check load cells for a level condition.
- Examine load cell cables and module interconnect cables for problems.
- Ensure that the SSCs and the PPSs covers are secure.

### 5.2. LOAD CELL REPLACEMENT

1. **Remove power** from the system at the instrument.
2. **Lift the scale** at the bad load cell location.
3. **Remove** the defective load cell.
4. Apply a small amount of **grease** on the load cell (top and bottom), then install it.
5. Gently **lower the scale assembly**, ensuring proper placement of the load cell.
6. Remove the SSC Enclosure Cover.
7. **Loosen the gland nut.**
8. **Unwire the defective load cell** from the SSC, noting the wire color code.
9. **Wire the new load cell** into the SSC.
10. Tighten the gland nut around the cable.
11. Secure the SSC enclosure latches.
12. **Re-apply power** to the instrument.
13. Check the scale's operation and **calibrate** it as necessary.



### 5.3. SSC BOARD REPLACEMENT

1. **Remove power** from the system at the instrument
2. **Remove the cover.**
3. **Disconnect all wiring**, noting their colors and terminal locations.
4. **Remove the screws** that secure the SSC board.
5. Note the dip switch settings, and **set dip switches for proper address** on new PC board.
6. **Install the new SSC board**, securing it with all the necessary screws.
7. **Connect all the wires** as they were before installing the new SSC board.
8. **Close the box.**
9. **Tighten all gland nuts** with pliers.

### 5.4. PPS BOARD REPLACEMENT

1. **Remove power** from the system at the instrument
2. **Remove PPS cover** and disconnect all wiring
3. Remove screws securing power board
4. **Remove old PCB**, secure ground wire to new PCB
5. **Remake all connections**, install the new PCB and secure all screws
6. **Close the box.**
7. Tighten all gland nuts.

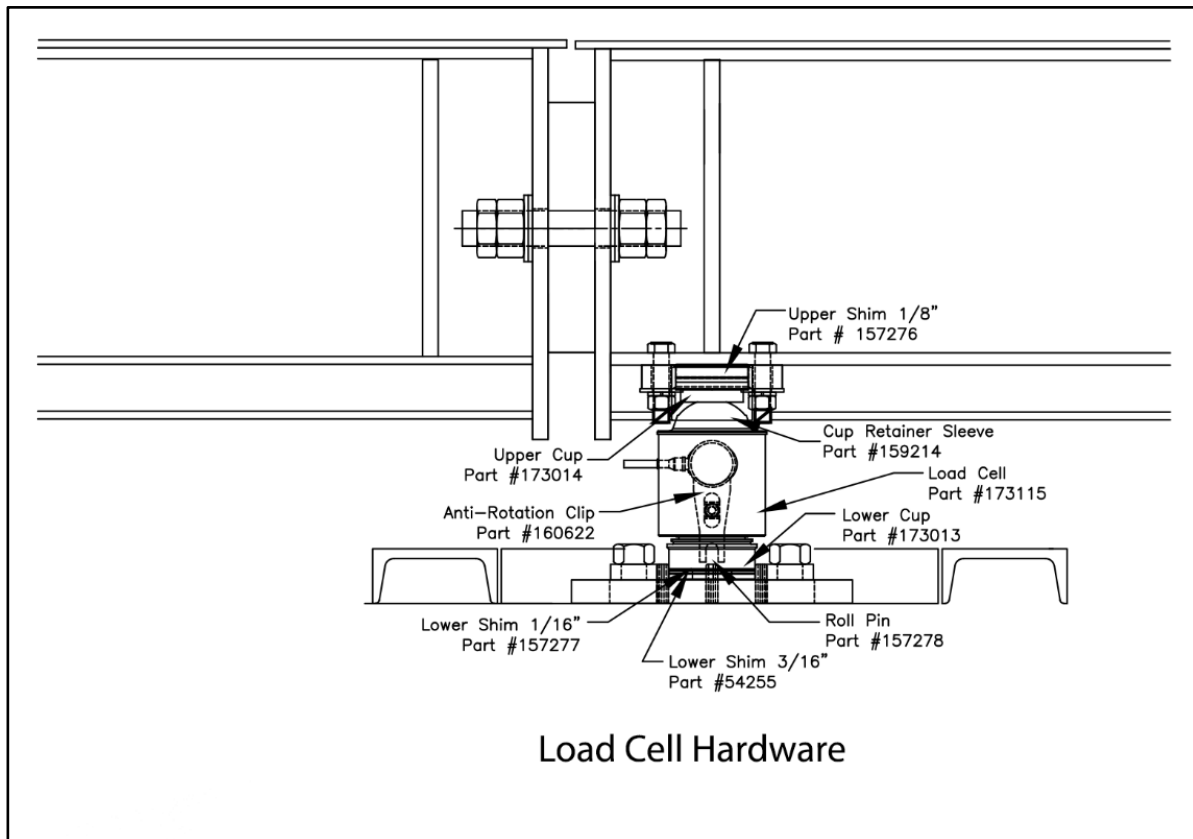
# Section 6: Parts

## 6.1. SCALE PARTS LIST

Part No.	Description
75458	1 1/8" x 4 1/2" w/ Nut (module - module)
54788	1 1/8" Lock Washer (module - module)
80955	Load Cell Base Plate
61743	Clamp Bar Washer (Base Plates)
62857	5/8" x 6" Anchor Bolts
55010	Ground Rod Kit

## 6.2. LOAD CELLS AND LOAD CELL HARDWARE

Part No.	Description
173115	Load Cell, 4 11/16" RC, 30t (66k), 1000 ohm, 2.4 mv/v
157277	Receiver Cup Shim, 1/16"
157276	Receiver Cup Shim, 1/8"
54255	Receiver Cup Shim, 3/16"
173013	LOWER Receiver Cup (w/ anti-rotation pin)
173014	UPPER Receiver Cup
157278	Roll Pin, Base Plate 3/8" x 1 1/4" cup retainer
157069	Locating Tool 4 11/16"



## 6.3. SPARE PARTS

### 6.3.1. Recommended Spare Parts

Part No.	Qty	Description
173115	1	Load Cell, 411/16" RC, 30t (or 66k)
175115	1	Load Cell, 411/16" RC, 50t (or 110k)
161197	1	Upper & Lower Cup (with anti-rotation pin) kit

### 6.3.2. Startup / Commissioning Spart Parts

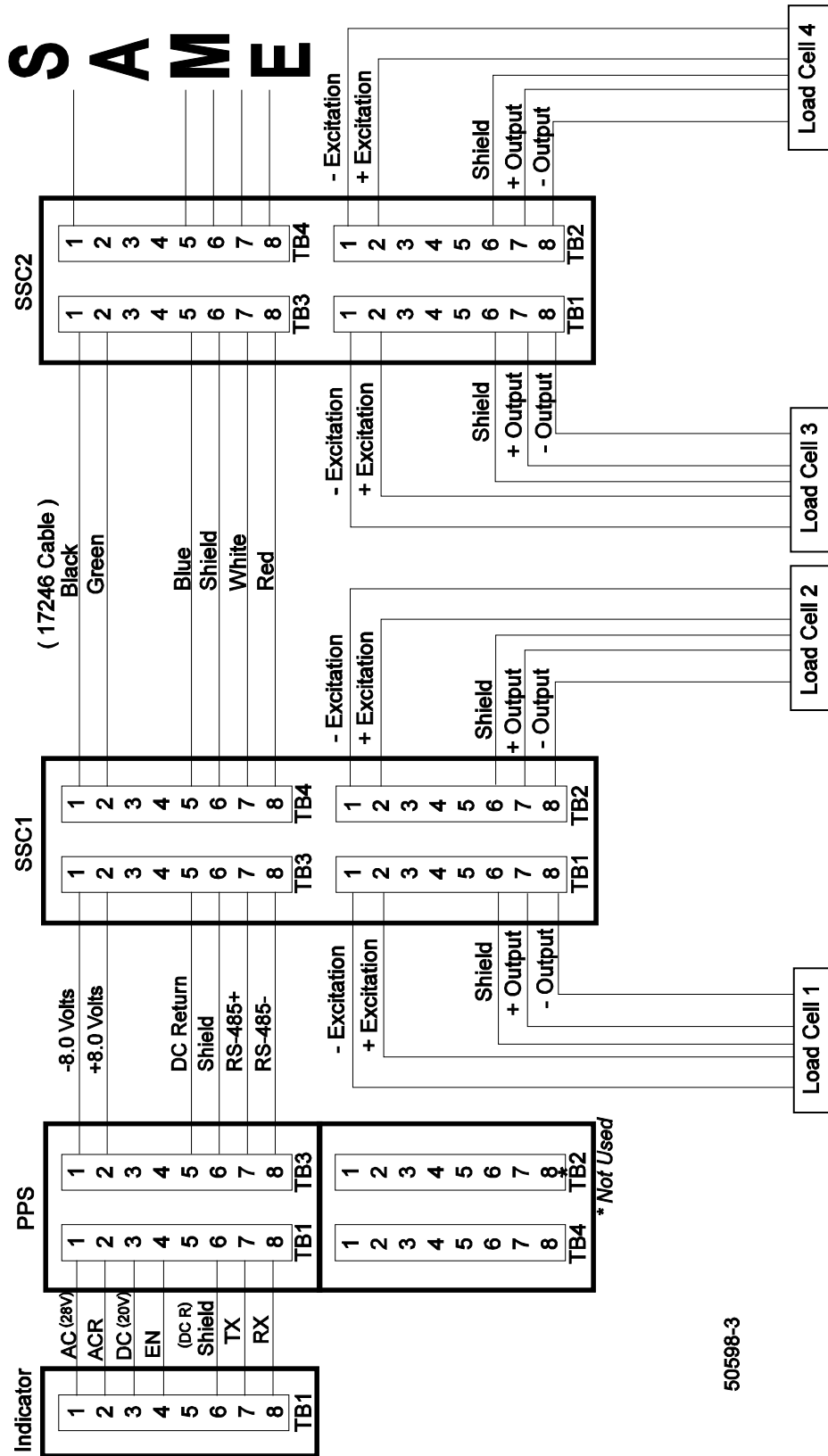
Part No.	Qty	Description
173115	1	Load Cell, 411/16" RC, 30t (or 66k)
175115	1	Load Cell, 411/16" RC, 50t (or 110k)

### 6.3.3. 2-Year Spare Parts List

Part No.	Qty	Description
173115	1	Load Cell, 411/16" RC, 30t (or 66k)
175115	1	Load Cell, 411/16" RC, 50t (or 110k)
161197	1	Upper & Lower Cup (with anti-rotation pin) kit
79747	1	Rub Rail PVC End Caps
105297	1	Rub Rail Plugs

**Capital Spare Parts** – Not Applicable

# Appendix I: Wiring



50598-3



Manufactured by Fairbanks Scales, Inc.

[www.fairbanks.com](http://www.fairbanks.com)

# **Talon Series**

---

**Portable Vehicle Scale**

**Document 51372**