

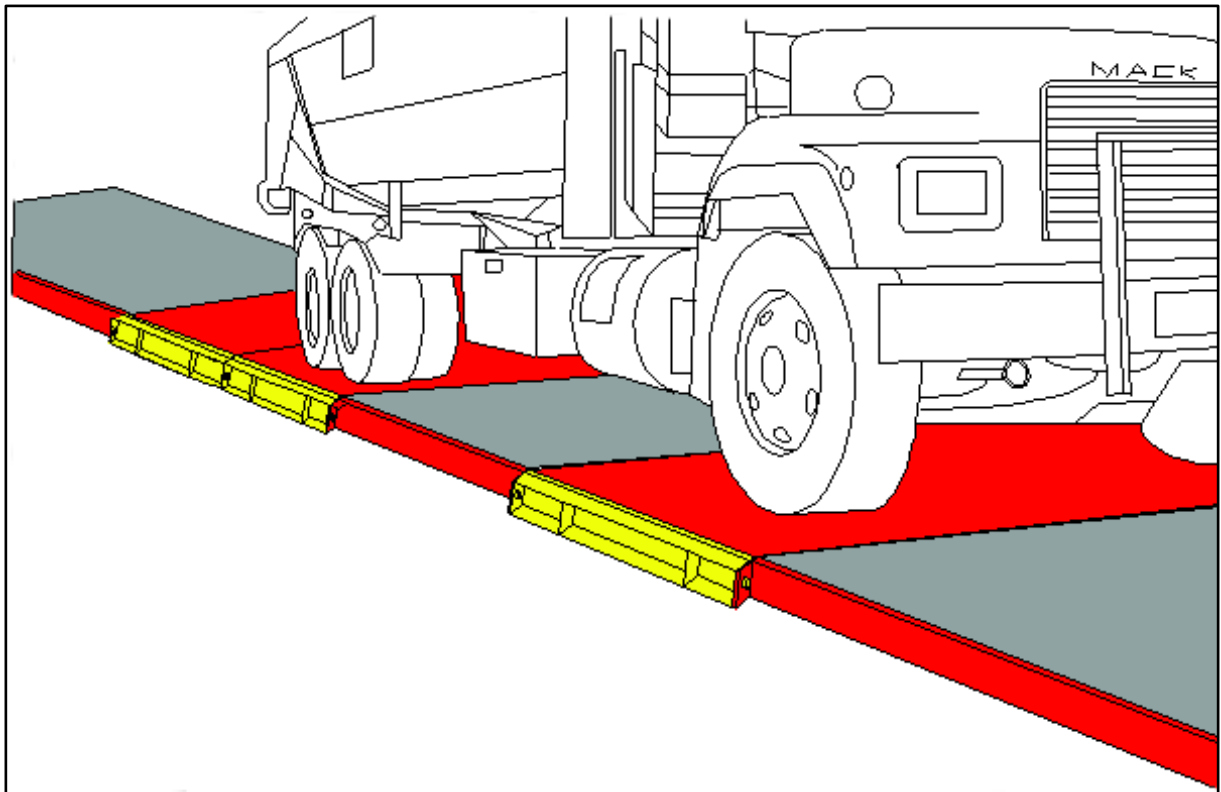

# PALS & Matrix Scale Highway Scale System





## **Disclaimer**

Every effort has been made to provide complete and accurate information in this manual. However, although this manual may include a specifically identified warranty notice for the product, Fairbanks Scale makes no representations or warranties with respect to the contents of this manual, and reserves the right to make changes to this manual without notice when and as improvements are made.

© **Copyright 2007-2021**

This document contains proprietary information protected by copyright. All rights are reserved; no part of this manual may be reproduced, copied, translated or transmitted in any form or by any means without prior written permission of the manufacturer.

# Amendment Record

## Matrix Scale Highway System Installation Manual

### Document 51182

Manufactured by **Fairbanks Scale Inc.**

Created	11/2007	
Revision 1	12/2007	Documentation Release
Revision 2	11/2012	Updated parts list to include analog assemblies
Revision 3	05/2014	Added securing of SSC's to frame information.
Revision 4	02/2017	Updated installation section and parts list
Revision 5	08/2018	Removed pictures from Appendix II
Revision 6	04/2019	Updated Installation section; Appendix Analog Wiring
Revision 7	09/2021	Added Appendix III; Spare parts list

---

# Table of Contents

---

<b>SECTION 1: GENERAL INFORMATION.....</b>	<b>6</b>
1.1. Description.....	6
<b>SECTION 2: COMPANY SERVICE INFORMATION.....</b>	<b>7</b>
2.1. Fairbanks Service Policies.....	7
2.1.1. Physical Installation Notes.....	7
2.1.2. Electronic Component Care.....	8
2.1.3. Conferring with Our Client.....	8
2.2. Phases of Installation.....	8
2.2.1. Pre-Installation Checklist.....	9
2.2.2. Unpacking and Equipment Checkout.....	9
2.2.3. Equipment Location and Safety.....	10
2.2.4. Users' Training and Responsibilities.....	10
<b>SECTION 3: INSTALLATION.....</b>	<b>11</b>
3.1. Introduction.....	11
3.2. Site Selection.....	11
3.3. Site Preparation – All foundation types.....	11
3.3.1. Foundation.....	11
3.3.2. PALS.....	12
3.3.3. Scale Positioning.....	13
3.4. Standard Platform Installation.....	13
3.5. Ramp Installation.....	15
<b>SECTION 4: MATRIX SYSTEM INSTALLATION.....</b>	<b>16</b>
4.1. Module Installation Steps.....	16
4.1.1. Preparing the Scale Frame.....	16
4.1.2. Lifting the Scales, Frames and Ramps.....	16
4.2. Pouring the Concrete.....	20
4.3. Ramp Installation.....	25
<b>SECTION 5: WIRING.....</b>	<b>27</b>
5.1. Description.....	27
5.2. Intalogix™ Digital Systems Wiring.....	27
5.2.1. Intalogix™ Systems Installation.....	27
5.2.2. Interconnection Wiring.....	28
5.2.3. Dip (Address) Switch Setup, SSCs.....	28
5.2.4. Cell Numbering.....	30
5.2.5. SSC Connections.....	30
5.2.6. Grounding.....	31
5.2.7. Instrument to Pit Power Supply Cable Connection.....	32
5.3. Analog Wiring.....	33
5.4. Data Recording.....	34
5.5. Moisture Protection.....	34
<b>SECTION 6: CALIBRATION.....</b>	<b>35</b>



**6.1. Preliminary Checks..... 35**  
**6.2. Repeatability and Return-to-Zero performance tests ..... 35**  
**6.3. Section Test and Adjustments..... 35**  
**6.4. Digital instrument span calibration ..... 35**

**SECTION 7: SERVICE & MAINTENANCE..... 36**

**7.1. Maintenance Inspections ..... 36**  
**7.2. Load cell replacement ..... 36**

**SECTION 8: REPLACEMENT PARTS ..... 37**

**8.1. Replacement Parts List ..... 37**  
**8.2. Replacement Parts Diagram..... 38**  
**8.3. Spare Parts..... 39**  
*8.3.1. Recommended Spare Parts ..... 39*  
*8.3.2. Startup / Commissioning Spare Parts..... 39*  
*8.3.3. 2-Year Spare Parts List ..... 39*

**APPENDIX I: WIRING DIAGRAMS ..... 40**  
*A. PALS Intalogix Digital Wiring..... 40*  
*B. PALS Analog Wiring..... 41*

**APPENDIX II: TYPICAL LAYOUT EXAMPLES ..... 43**

**APPENDIX III: SHIM DIMENSIONS ..... 45**

---

# Section 1: General Information

---

## 1.1. Description

The **MATRIX Scale System** is a combination of strategically placed **Portable Axle Load Scales (PALS)**.

Multiple PALS becomes a MATRIX only when the vehicle weighed is fully scale-borne.

Concrete or steel dead spaces are placed between the live scales to accomplish correct spacing to accommodate the vehicle being weighed.

Concrete approaches are placed as stated in **NIST Handbook H44**.

Because every axle or set of axles is on its own scale, every MATRIX Scale can be a highway system scale.

Matrix scales are one directional and have an entrance and an exit end.

PALS scales are offered in sizes of **7' x 10'**, **10' x 10'**, **14' x 10'**, **17' x 10'**, and **20' x 10'**.

PALS are offered in a **60K CLC** and an **80K CLC**.

---

## Section 2: Company Service Information

---

### 2.1. Fairbanks Service Policies

Prior to installation, ***always*** verify that the equipment satisfies the customer's requirements as supplied, and as described in this manual.

If the equipment cannot satisfy the application and the application cannot be modified to meet the design parameters of the equipment, **the installation should NOT be attempted.**



It is ***the customer/operator's responsibility*** to ensure the equipment provided by Fairbanks is operated within the parameters of the equipment's specifications and protected from accidental or malicious damage.

## WARNING!

**Absolutely no physical, electrical or program modifications other than selection of standard options and accessories can be made by customers to this equipment.**

**Repairs are performed by Fairbanks Scales Service Technicians and Authorized Distributor Personnel ONLY!**

***Failure to comply with this policy voids all implied and/or written warranties.***

### 2.1.1. Physical Installation Notes

Check all devices for proper operation. If any error messages occur, refer to Troubleshooting or the proper manual of that device.

***Only those charges which are incurred as a result of the equipment's inability to be adjusted to performance specifications may be charged to warranty.***

No physical alterations (mounting holes, etc.) are allowed during installation.

### **2.1.1. Physical Installation Notes, Continued**

***The installing technician is responsible that all personnel are fully trained and familiar with the equipment's capabilities and limitations before the installation is considered complete.***

### **2.1.2. Electronic Component Care**

Much of the equipment consists of printed circuit assemblies, which ***must be*** installed using **ESD handling procedures**.

These assemblies must be replaced as assemblies or units.

Replacement of individual components is not allowed.

The assemblies must be properly packaged in ESD protective material.

These components must be returned intact for replacement credit per normal procedures.

### **2.1.3. Conferring with Our Client**

***Before the installation is considered complete, the equipment is to be programmed to meet or exceed any applicable weights and measures requirements.***

The technician must be prepared to recommend the arrangement of components which provide the most efficient layout, utilizing the equipment to the best possible advantage.

The warranty policy must be explained and reviewed with the customer.

## **2.2. Phases of Installation**

**The complete installation consists of the following phases:**

- A. Pre-Installation Checklist**
- B. Unpacking and Equipment Checkout**
- C. Equipment Location and Safety**
- D. Users' Training and Responsibilities**



### **2.2.1. Pre-Installation Checklist**

The following points should be checked and discussed with the **Area Sales Manager and/or customer**, if necessary, before the technician goes to the site and installs the equipment.

- ✓ Check the customer's application to make certain it is within the capabilities and design parameters of the equipment.
- ✓ If the installation process might disrupt normal business operations, tell the customer and ask that they make ample arrangements.
- ✓ Is properly grounded power available at the installation location?
- ✓ Be sure that the equipment operator(s) are available for training.
- ✓ The Service Technician must thoroughly review the installation procedures.
- ✓ The service technician reviews the recommended setup with the Area Sales Manager or Area Service Manager, and together they identify all necessary variations to satisfy the customer's particular application.



### **2.2.2. Unpacking and Equipment Checkout**

Follow these guidelines when unpacking all equipment:

- ✓ Check in all components and accessories according to the customer's order.
- ✓ Remove all components from their packing material, checking against the invoice that they are accounted for and not damaged.
  - *Advise the shipper immediately, if damage has occurred.*
  - *Order any parts necessary to replace those which have been damaged.*
  - *Keep the shipping container and packing material for future use.*
  - *Check the packing list.*
- ✓ Collect all necessary installation manuals for the equipment and accessories.
- ✓ Open the equipment and perform an inspection, making certain that all hardware, electrical connections and printed circuit assemblies are secure.
- ✓ Do not reinstall the cover if the final installation is to be performed after the pre-installation checkout.



### 2.2.3. *Equipment Location and Safety*

Follow these safety precautions during operation:

- ✓ Do not load the platform if there is any evidence of damage to the platform or supporting structure.
- ✓ Use safety chains or other suitable restraining devices if there is any possibility of the load shifting, falling, or rolling from its position on the platform.



### 2.2.4. *Users' Training and Responsibilities*

- ✓ All electronic and mechanical calibrations and/or adjustments required for making this equipment perform to accuracy and operational specifications are considered to be part of the installation.
  - They are included in the installation charge.
  - Only those charges which are incurred as a result of the equipment's inability to be adjusted or calibrated to performance specifications may be charged to warranty.
- ✓ Absolutely no physical, electrical or program modifications other than selection of standard options and accessories are to be made to this equipment.
  - Electrical connections other than those specified may not be performed, and physical alterations (holes, etc.) are not allowed.
- ✓ The equipment consists of printed circuit assemblies which must be handled using ESD handling procedures and must be replaced as units.
  - Replacement of individual components is not allowed.
  - The assemblies must be properly packaged in ESD protective material and returned intact for replacement credit per normal procedures.

---

## Section 3: Installation

---

### 3.1. Introduction

The standard installation of the Portable Axle Load Scale consists of locating the platform, leveling the platform, installing the ramps, interfacing the platform to an instrument, and calibrating/ adjusting the system.

### 3.2. Site Selection

- Locate the platform to allow convenient maneuvering of vehicles of the platform.
- The location should provide a solid base to support the platform and be level.
- The location must be able to support the platform plus the weight that will be placed upon it.

### 3.3. Site Preparation – All foundation types

Assist the customer in selecting a site which allows easy access to and from the scale, ensuring enough area for straight and level approaches, and to meet all **State and Local Weights and Measures Regulations**.

- The site needs good drainage away from the scale, elevated enough so the surrounding areas ***drain away from the scale site***.
- Obtain all the necessary permits and licenses prior to beginning construction.

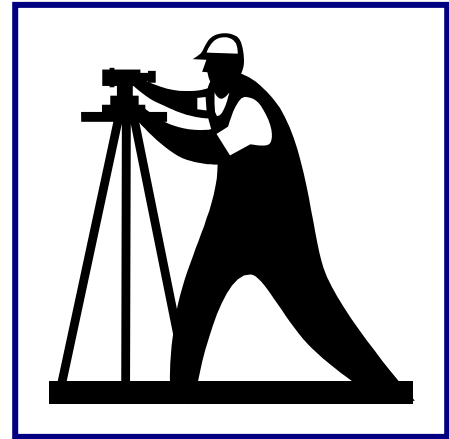

#### 3.3.1. Foundation

PALS **DO NOT** require a typical concrete foundation. However, they do require a flat and level unyielding surface.

The surface needs to be either concrete or asphalt.

### 3.3.2. PALS

All PALS come preassembled and palletized from the factory.



Load Cells are preinstalled, plumbed and pre-wired to the Smart Sectional Controllers (SSCs) Junction Box prior to shipping.

SSC or Junction Boxes are installed at the factory.

- The Dip Switches are **not set**.
- Interconnecting Cables are **not installed**.

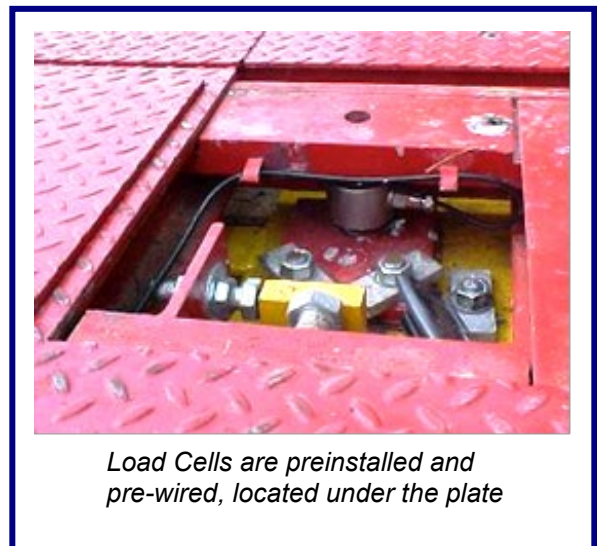

*Load Cells are preinstalled and pre-wired, located under the plate*

End and Side Checking is also pre-set at the factory according to manufacturer's specification.

Tie-down Bolts are installed at the factory for shipping.

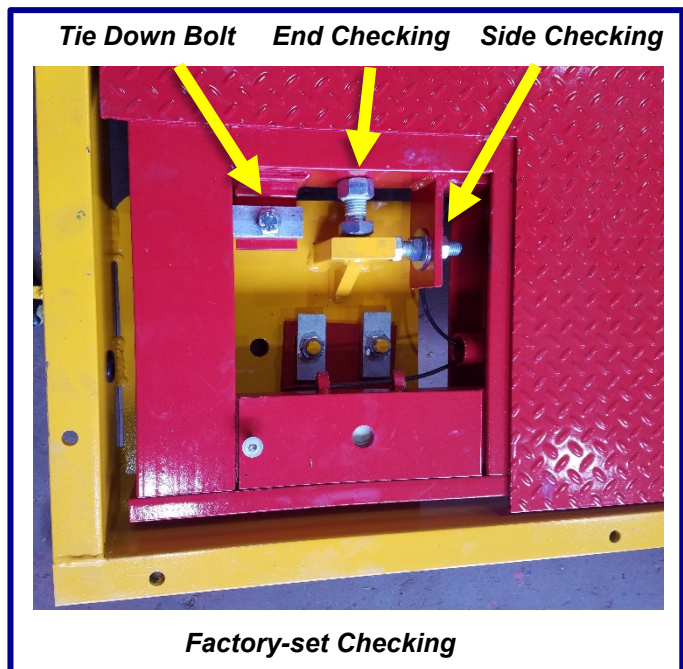

**Factory-set Checking**

### 3.3.3. Scale Positioning

Position the scale so that vehicles can approach and exit the scale easily and straight.

- ✓ Smooth and level approaches are required at each end of the platform to reduce loading shock, and to facilitate testing of the scale.
- ✓ Approaches must conform to the requirements of the law in the state in which the scale is being installed.
- ✓ In the absence of such laws, the approaches must conform to **Paragraph UR.2.6** of the *National Institute of Standards and Technology Handbook 44*, which states that the first 10 feet must be level and on the same plane as the scale platform.
- ✓ The platform should be visible from the instrument location.
- ✓ Surface water must drain easily, and not collect, under the scale.
- ✓ The substructure must have a **minimum bearing pressure of 3000 PSF**, or as specified on the **Fairbanks Certified Prints**.

---

**NOTE:** Always... “CALL BEFORE YOU DIG”.

**1-888-258-0808**

---

## 3.4. Standard Platform Installation

1. The platform is shipped fully assembled and wired. Remove the platform from the packing materials.
2. Connect lifting straps or chains to the lifting lugs on the sides of the platform. The lifting straps/chains should be long enough to form a 45-degree angle with the platform during the lifting process.
3. Place the platform in the desired location.
4. The platform should be made stable and level. Shims can be used sparingly to ensure the platforms are completely level but are not intended to be used for “extra clearance” underneath the scales. The scales are designed to be set on a solid ground and not have clearance underneath the frames. If shims greater than ½” are required, further site preparation is required to remedy the difference. Shims are not included with the platform

and must be supplied locally as needed. Refer to Appendix III for specs on the shims.

5. Remove the four (4) cover plates.
6. Drill and anchor the platform using the supplied  $\frac{3}{4}$ " wedge anchors.

**WARNING:** Absolutely no arc welding operations are to be performed on or near this scale while the load cells are in place and/or connected. All load cells must be disconnected and removed during welding.

### Top View of Cover Plate

7. Remove the shipping bolts in each corner.
8. Adjust the checking bolts to a  $\frac{1}{16}$ " to  $\frac{1}{8}$ " clearance.
9. Verify all the load cells are plumb, square and level. Correct if necessary.
10. If ramps are part of the installation, they should be located and installed at this time.



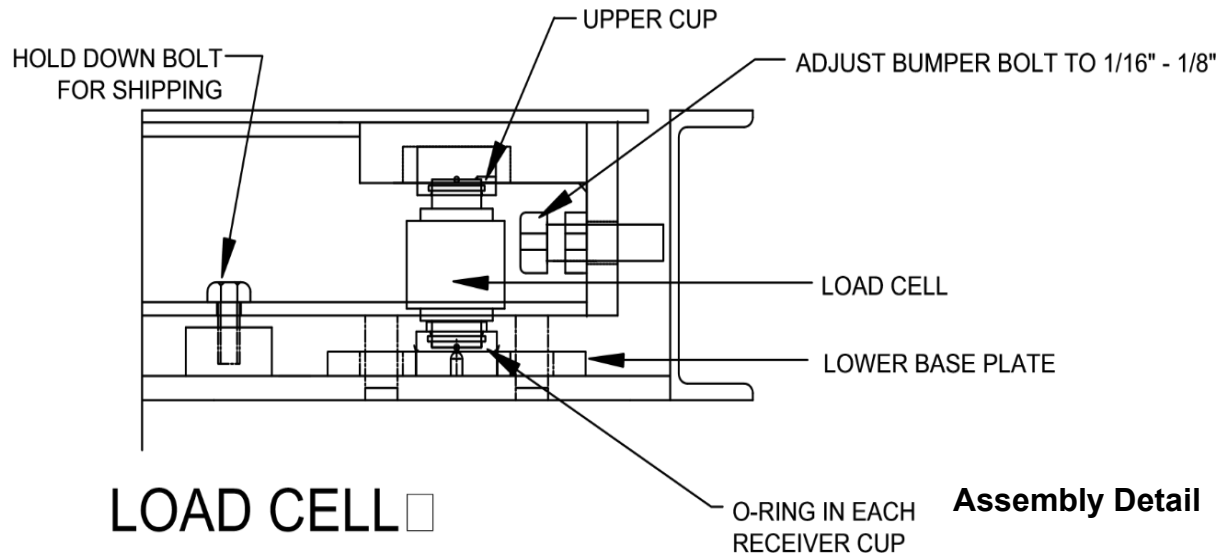

### 3.5. Ramp Installation

The ramps are used in combinations in specific applications.

1. Each ramp has two (2) bolt down tabs as part of the ramp.
2. Place the ramp against the the platform frame.
3. The ramp should be made stable and level.  
Shims are not included with the ramps and must be supplied.
4. Bolt the ramps to scale frame using  $\frac{3}{4}$ " hardware.
5. Drill and anchor the ramp(s) using the supplied  $\frac{3}{4}$ " wedge anchors.
6. No more than two (2) ramps, located on opposite sides of the platform, may be installed.

---

# Section 4: Matrix System Installation

---

## 4.1. Module Installation Steps

### 4.1.1. Preparing the Scale Frame

1. Lay out the scale.
2. Mark chalk lines on the flat, level surface.
  - a. Mark the center line of the scale first.
  - b. Mark the edges of the scale.
  - c. Refer to the **Fairbanks Certified Prints** for exact dimensions.



### 4.1.2. Lifting the Scales, Frames and Ramps

- When moving the elements of the scale assembly, **place the hooks** of the straps or chains **into the specific lifting points**.



*Scale and frame lifting points*



*Ramp lifting points*



## 4.1. Module Installation Steps, Continued

1. Set the **Exit Approach** concrete frame.
2. Starting from one end of the scale, set up the **Approach Concrete Frame**.
  - Line up the **Approach** to match the chalk lines.



3. Set the Steering Axle Scale adjacent to the Approach Concrete Frame.
  - Line up the **Steering Axle Scale** and the **Approach Concrete Frame** to match the chalk lines.

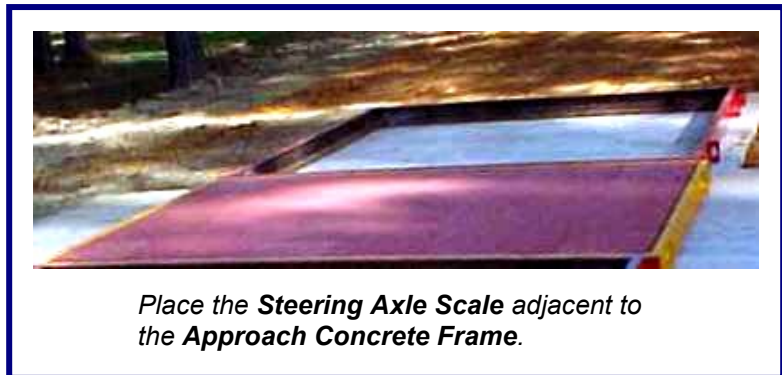

4. Fasten the Steering Axle Scale to the Approach Concrete Frame using the supplied hardware specified on the **Fairbanks Certified Drawings**.



## 4.1. Module Installation Steps, Continued

5. Set the Concrete Dead Space Frame at the end of the Steering Axle Scale.

- Line up the **Concrete Dead Space Frame** to match the chalk lines.

6. Bolt the Concrete Dead Space Frame to the Steering Axle Scale.



7. Set the Drive Axle Scale at the end of the first Concrete Dead Space.

- Line up the **Drive Axle Scale** to match the chalk lines.

8. Bolt the Drive Axle Scale to the Concrete Dead Space.



9. Set the Concrete Dead Space Frame at the end of the Drive Axle Scale.

- Line up the **Concrete Dead Space Frame** to match the chalk lines.

10. Bolt the Concrete Dead Space Frame to the Drive Axle Scale.



## 4.1 Module Installation Steps, Continued

11. Set the next **Concrete Dead Space Frame** at the end of the **Concrete Dead Space Frame**.

- Line up the **Concrete Dead Space Frame** to match the chalk. lines.

12. Bolt the Concrete Dead Space Frame to the Drive Axle Scale.



13. Place the Trailer Axle Scale against the Concrete Dead Space Frame.

- Line up the **Concrete Dead Space Frame** to match the chalk. lines.

14. Bolt the Trailer Axle Scale to the Concrete Dead Space Frame.



15. Set the Approach Concrete Frame at the end of the Trailer Axle Scale.

- Line up the **Drive Axle Scale** to match the chalk. lines.

16. Bolt the Approach Concrete Frame to the Trailer Axle Scale.



## 4.2. Pouring the Concrete

1. Prepare to pour the concrete into the Dead Space Frames and Approaches by installing ***plastic sheeting (not provided) for each section.***
2. Tape the edges to protect the paint from spillage concrete, and also for easy clean up.

**NOTE:** *Plastic sheeting for each section is not provided by Fairbanks Scales as a part of this unit kit.*



## 4.2. Pouring the Concrete, Continued



*The scale assembly is ready to pour.*

### Concrete Guidelines

Follow these guidelines when pouring the deck concrete in the modules.

- Pour concrete to 3500 psi minimum compressive strength.
- 5%-7% air entrainment is required.
- Follow latest **ACI Requirements** for materials and construction
- Cast **only if** the air temperature is **above 40° F.**



## 4.2. Pouring the Concrete, Continued

3. Starting from one end, pour each of the concrete frames.



4. Vibrate the concrete when filling the frames or when crowning.



## 4.2. Pouring the Concrete, Continued

5. Once all frames are filled, vibrated and crowned, bull float and finish the concrete.



6. Apply a broom finish on the concrete.

## 4.2. Pouring the Concrete, Continued

7. Clean all concrete off the scale wherever it does not belong.



8. Slowly remove the tape to reveal the clean painted frames.

9. Drill and anchor the platforms using the supplied  $\frac{3}{4}$ " wedge anchors. See arrows in the diagram below for anchor locations.

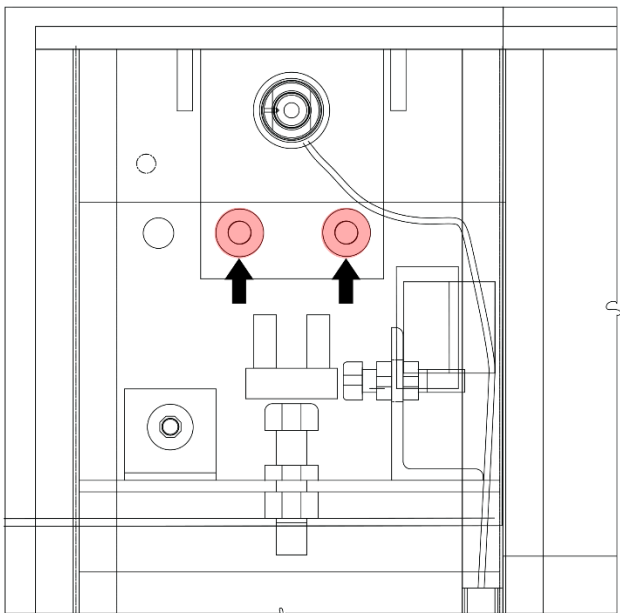



## 4.2. Pouring the Concrete, Continued

10. The installation is complete.

- All areas of the scale are completely cleaned of all excess concrete, tape, and any trash.
- Remove and roll up the protective plastic.



## 4.3. Ramp Installation

### NOTES:

- Each ramp has two (2) **bolt down tabs** as part of the ramp.
- **Shims** may be used sparingly to ensure the ramp is even and positioned correctly with the scale frames. Shims are not included with the ramps and must be supplied locally. Shims greater than ½” are not included.
- No more than two (2) ramps, located on opposite sides of the platform, may be installed.

## Installing the Ramp(s)

1. Place the ramp against the approach frame.
2. Make the ramp stable and level against the scale frame.
3. Bolt the ramps to scale frame using the supplied hardware.



4. Drill and anchor the ramp(s) using the supplied 3/4" wedge anchors.

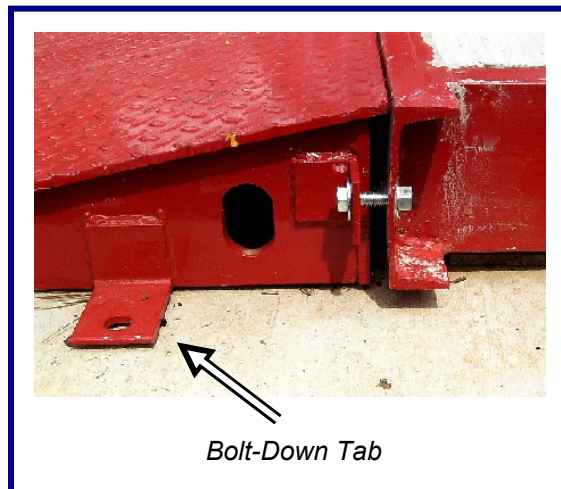

---

# Section 5: Wiring

---

## 5.1. Description

The Matrix Scale System uses either the **Intalogix™ Digital** or **Analog** wiring.

## 5.2. Intalogix™ Digital Systems Wiring

The **Intalogix™ Systems**, which utilize **Smart Sectional Controllers (SSC)** and **Pit Power Supplies (PPS)** for load cell excitation and signal processing.

Most applications use **one (1) SSC per section**, and **one (1) PPS for the entire platform**.

- This applies until the number and resistance of the cells require a second pit power supply.

**SSC boxes have four (4) terminals.**

- Two (2) terminals are used for load cells and two (2) for interfacing to other SSC boxes or terminating to a pit power supply.
- All cell/section/scale adjustments are made using the **Intalogix™ System Instrument**.

### 5.2.1. Intalogix™ Systems Installation

#### Boxes

The boxes are located in the **Junction Box Storage Area** in each module.

#### Wiring

Cable used in all wiring must be a minimum of **18 AWG**.

Use cable **17204** or **17246**.

Use appropriate service manual for the instrument being installed or refer to the **Appendix I** for typical wiring information.

#### Smart Sectional Controller (SSC)

Wire cells into each sections sectional controller per the appropriate service manual. Refer to the Appendix for typical wiring information.

### 5.2.1. Intalogix™ Systems Installation, Continued

#### Load Cell Wiring Designations

Color	Description
Black	(-) Excitation
Green	(+) Excitation
Red	(-) Signal
White	(+) Signal
Yellow	Shield

### 5.2.2. Interconnection Wiring

TB3 or TB4 in SSC	Function	17246 Cable
1	(-) 8.0 volts	Black
2	(+) 8.0 volts	Green
5	DC Return	Blue
6	Shield	Shield
7	RS-485 (+)	White
8	RS-485 (-)	Red

### 5.2.3. Dip (Address) Switch Setup, SSCs

In each of the SSC boxes, there is a ten (10) position dip switch labeled **S1**.

- This switch is used to identify the section in a binary code.

The switches must be set properly for the scale to operate.

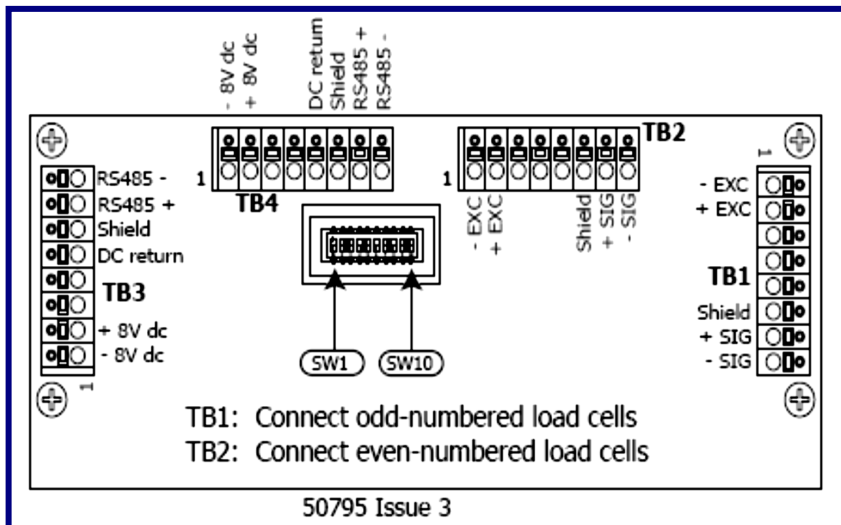

**NOTE:** Switches 1, 2, 3, 4, are **always OFF**.

**SW 1 position 5 setting:**

**OFF = 350 Ω load cells**

**ON = 700/1000 Ω load cells**

### 5.2.3. Dip (Address) Switch Setup, SSCs continued

Switches **6 thru 10** set the **Section [Address] Numbers**.

Set the **Section Number** according to the following chart.

Each SSC Box has a unique Section Number entered on the dip switches.

Section Number	Switch Settings				
	6	7	8	9	10
Section 1	On	Off	Off	Off	Off
Section 2	Off	On	Off	Off	Off
Section 3	On	On	Off	Off	Off
Section 4	Off	Off	On	Off	Off
Section 5	On	Off	On	Off	Off
Section 6	Off	On	On	Off	Off
Section 7	On	On	On	Off	Off
Section 8	Off	Off	Off	On	Off
Section 9	On	Off	Off	On	Off
Section 10	Off	On	Off	On	Off
Section 11	On	On	Off	On	Off
Section 12	Off	Off	On	On	Off
Section 13	On	Off	On	On	Off
Section 14	Off	On	On	On	Off
Section 15	On	On	On	On	Off
Section 16	Off	Off	Off	Off	On

### 5.2.4. Cell Numbering

Intalogix™ Technology installations use a specific numbering system for load cells because of digital addressing of the SSCs.

With respect to the following starting position, face the platform where the indicator is located.

The cell at the **upper-left** (far side) of the platform is **Cell One (1)**.

The cell positions along the **far side** have **odd cell numbers**.

The **near side locations** have **even cell numbers**.

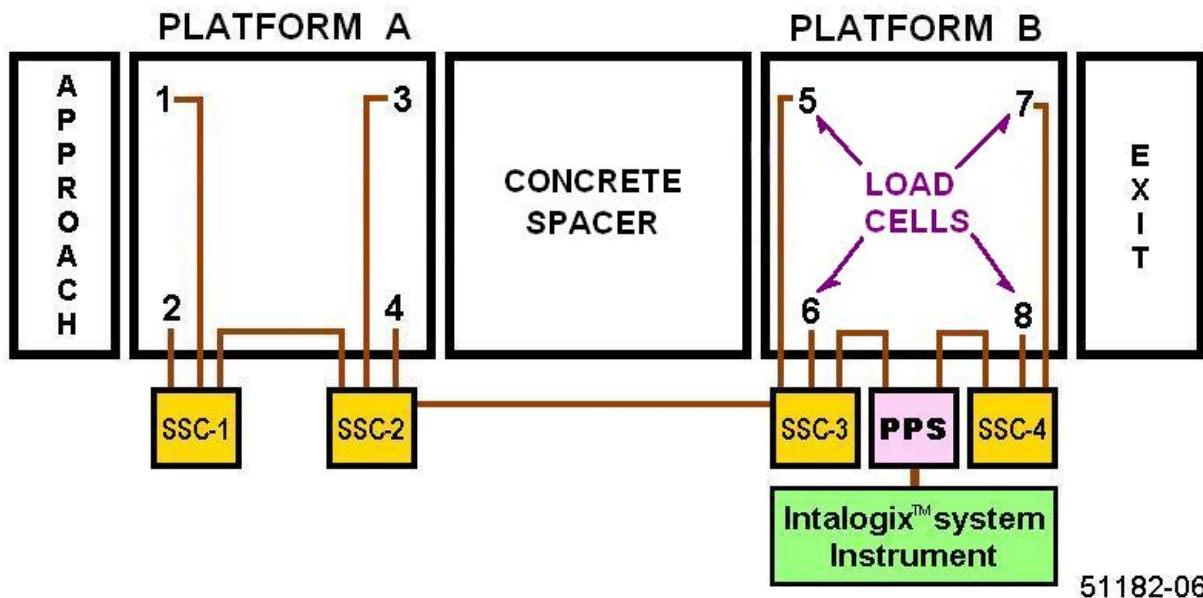

### 5.2.5. SSC Connections

Each SSC has connections for two (2) incoming load cells, labeled **TB1** and **TB2**.

The **odd** numbered cell goes to **TB1**.

The **even** numbered cell goes to **TB2**.

### 5.2.6. Grounding

Intalogix™ Technology systems require one (1) grounding rod per weighbridge, and one (1) grounding rod per Pit Power Supply.

These grounding rods are supplied with the scale.

For accurate operation and protection against damage from lightning strikes, all of the components of the system must be properly grounded.

Use the following guidelines to correctly ground the system.

Use **8 AWG** or larger wire, or **braided ground straps**.

All ground connections should be **two feet (2')**, or as short as possible.

The SSCs and PPSs housing attaches in a clean electrical connection **to the platform frame** using self-tapping screws. The platform frame is then connected to a pit ground rod.

The insulated **WHITE WIRE** from the PPS connects directly to the separate ground rod, **and not to the same rod as the weighbridge**.

The **117 VAC SVP Unit** connects to a known good ground at the instrument location.

- Use a voltmeter to test the electrical power source available.
- The **Neutral-to-Ground** voltage level must be **0.2 VAC or less**.
- If unsure, or if the testing reveals higher than 0.2 VAC, install a separate ground rod at the **SVP location**, connecting it with braided cable or 8 AWG wire.

# C A U T I O N

**Proper grounding is REQUIRED**  
so the Surge Voltage Protection (SVP) adequately shields the scale from lightning and other electrical interferences!

### 5.2.7. Instrument to Pit Power Supply Cable Connection

Prepare the cable ends in the standard manner. Use the appropriate manual for wiring the sectional controllers and power supplies. Connect the instrument interface cable to the instrument in the scale house as shown in the service manual.

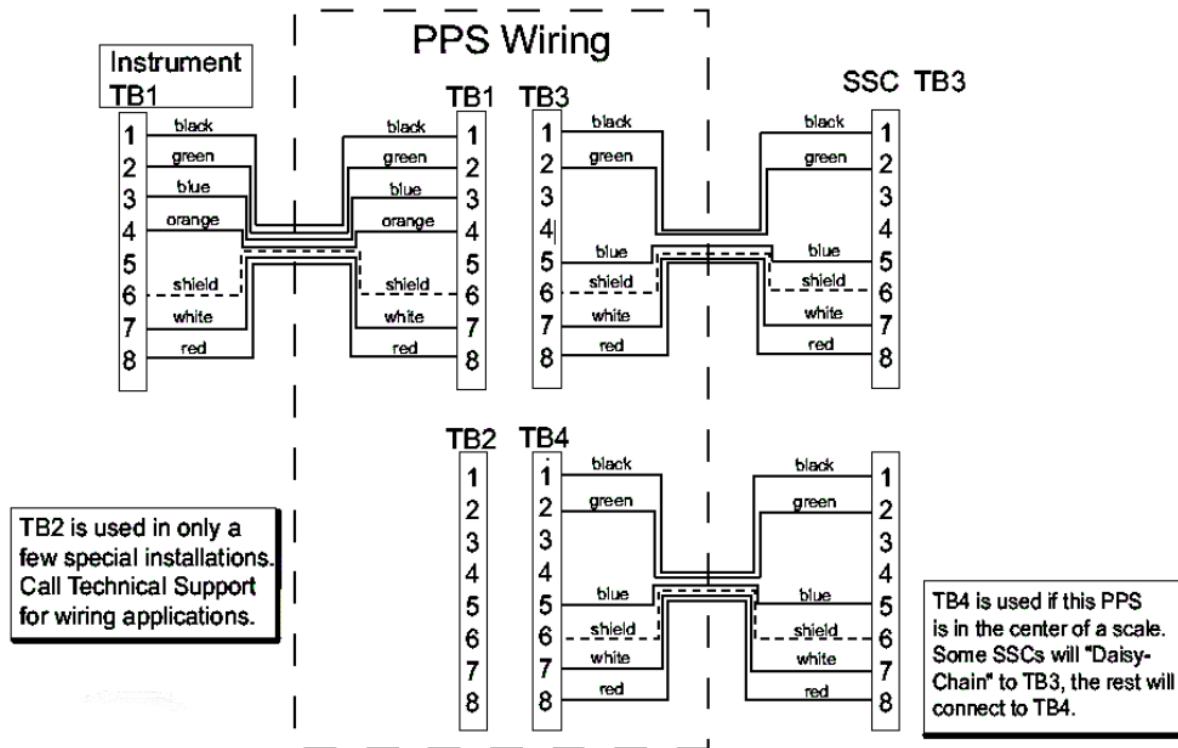

Connect the **PPS to an SSC** (#1 or any SSC).

Feed a cable from **SSC #1 TB3** through the bushing for in the **PPS for TB3**.

Connect the wires as shown in this chart.

TB3 SSC#1	TB3 PPS	17246 Cable	Description
1	1	Black	(-) 8.0 volts
2	2	Green	(+) 8.0 volts
5	5	Blue	DC Return
6	6	Shield	Shield
7	7	White	RS-485 (+)
8	8	Red	RS-485 (-)



### 5.2.8. Instrument to Pit Power Supply Cable Connection, continued

Wire the PPS to the Instrument.

- Run the **Home-Run Cable** from the **PPS – TB1** to the **Instrument's TB1**.
- **Shields** are used for **DC Return** and **MUST BE CONNECTED**.

Connect the wires as shown in this chart.

TB1 PPS	TB1 Inst	17246 Cable	Description
1	1	Black	28 volts, AC
2	2	Green	AC Return
3	3	Blue	20 Volts, DC
4	4	Orange	Enable
6	6	Shield	Shield/DC Return
7	7	White	Transmit
8	8	Red	Receive

## 5.3. Analog Wiring

The platforms are shipped fully assembled and wired. Wire the interface cable to the instrument according to this chart.

L/C Wire Color	Function	Analog Instrument
Black	(–) Excitation	(–) Excitation
Green	(+) Excitation	(+) Excitation
Yellow	Shield	Shield
White	(+) Signal	(+) Signal
Red	(–) Signal	(–) Signal

---

**NOTE:** Refer to the proper instrument service manual for proper installation, programming, and calibration of the instrument.

---

### 5.3. Analog Wiring, Continued

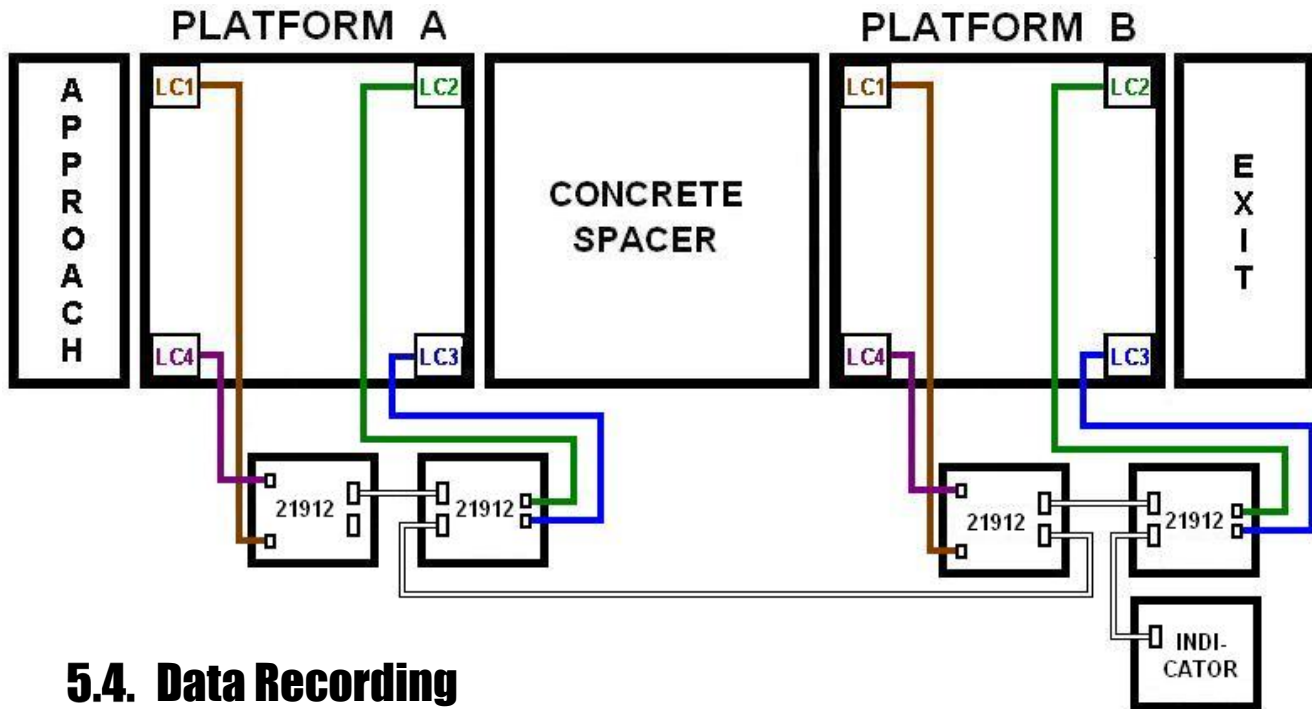

### 5.4. Data Recording

1. Record scale serial number from the tag.
2. Record instrument, junction box and load cell serial numbers.
3. Keep a copy of the sheet in the customer file.

### 5.5. Moisture Protection

Full Electronic Scales have been designed to provide protection from the effects of moisture.

The load cells are calibrated with the cable attached.

**The cable *MUST NOT* be cut.**

The cable is connected directly to the Junction Box through a sealed bushing which ***MUST BE TIGHTENED WITH PLIERS*** to keep moisture out of the box.

On **all** boxes, the black plastic fittings have O-rings that can be forced out of position if the bushing itself is not tight.

- To prevent this, first tighten the inner nut securing the bushing in the hole.
- Then insert the cable and carefully tighten gland with pliers until it is very snug.
- ***DO NOT over-tighten*** where bushing 'turns'.
- All box covers ***MUST BE SECURED*** with ***ALL*** screws tightened properly (**18 to 20 lbs/in**) for protection against moisture.

---

## Section 6: Calibration

---

### 6.1. Preliminary Checks

Seat the suspension components. Drive the test truck across the scale stopping and starting several times across the scale. Repeat this procedure **at least three times** to assure that all parts are properly seated.

Refer to the appropriate technical manual for the particular Intalogix™ Technology Instrument for the setup and calibration procedures.

### 6.2. Repeatability and Return-to-Zero performance tests

1. **Position the test truck** in the center of the Weighbridge.
2. Note the **weight reading**.
3. Pull the truck off the scale and note the **Return-to-Zero**.
4. **Repeat this procedure** at least three times to assure consistency.
5. If the scale does not repeat the readings (within tolerance), check for mechanical obstructions or binds.
  - Check the scale thoroughly for proper assembly.
  - Check to see the load cells are properly aligned, level, and the load is equally distributed on each load cell.
  - Add or remove shims as required to improve deadload distribution.

### 6.3. Section Test and Adjustments

1. Test the section by centering the test load over each section.
  - A weight cart, block weights, rear axles of the test truck.
2. Note the weight indication of each section.
  - Adjusted each section so the weight indications match within the tolerances set forth by the **National Institute of Standards and Technology's Handbook H-44**.
3. Trim the sections by placing the test load over each section, and then adjusting it as described in the appropriate Intalogix™ instrument service manual.

### 6.4. Digital instrument span calibration

Perform the span adjustments, following the appropriate **Intalogix™ Instrument service manual**.

---

# Section 7: Service & Maintenance

---

## 7.1. Maintenance Inspections

Ensure that the system is maintaining proper ground connections.

Check module-to-module bolts for tightness.

Check that the frame has not shifted, and that all bolts are secure.

Check for movement or washout under any temporary pier structures.

Check load cells for a level condition.

Examine load cell cables and module interconnect cables for problems.

Ensure that the SSCs and the PPS covers are secure.

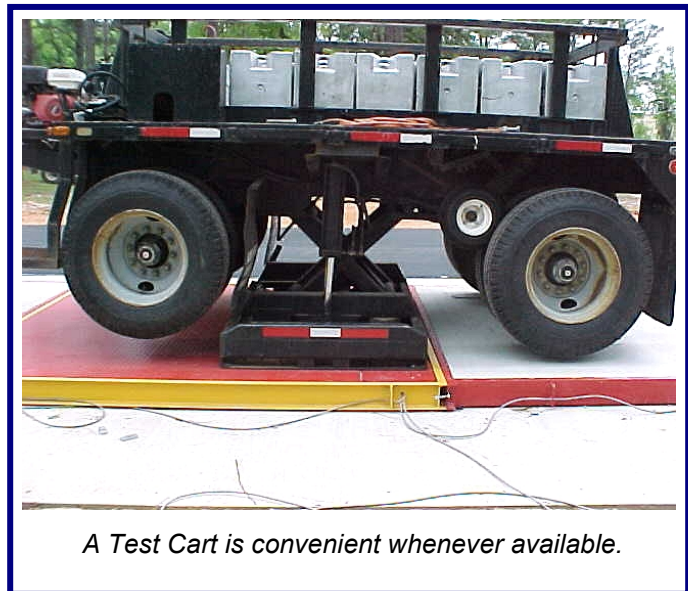

## 7.2. Load cell replacement

1. **Remove power** from the system at the instrument.
2. **Lift the scale** at the bad load cell location.
3. **Remove** the defective load cell.
4. Apply a small amount of **grease** on the load cell (top and bottom), then install it.
5. Gently **lower the scale assembly**, ensuring proper placement of the load cell.
6. Remove the SSC Enclosure Cover.
7. **Loosen the gland nut.**
8. **Unwire the defective load cell** from the SSC, noting the wire color code.
9. **Wire the new load cell** into the SSC.
10. Tighten the gland nut around the cable.
11. Secure the SSC enclosure latches.
12. **Re-apply power** to the instrument.
13. Check the scale's operation, and **calibrate** it as necessary.

## Section 8: Replacement Parts

### 8.1. Replacement Parts List

ITEM	QTY	PART No.	Description
3	4	105786	BASE PLATE W/ LOWER CUP
4	4	54517	3/4" – 10 X 2" HEX HD, CAP SCREW
5	2	26168	SSC BOX ASSY (ACC-2000-1A)
6	2	54203	NUT, HEX SST 10-24
7	5 IN	14721	VELCRO LOOP
8	5 IN	14722	VELCRO HOOK
9	4	83669	FTEC 3 1/2" ROCKER 50K 15' CBL
10	4	105718	UPPER CUP W/O ANTI ROTATION (2 1/2" diameter)
11	8	54233	3/4 - FLAT WASHER
12	12	54264	3/4 - 10 HEX NUT
13	5	66979	SS 1/2" – 13 X 1" FLAT HD. MACH SCREW
14	12	61743	CLAMP BAR
15	4	54878	3/4" HEX JAM NUT
16	4	54559	3/4" – 10 X 3" LG., HEX HD CAP SCREW
17	4	60237	1" – 8 X 5" LG., HEX HD CAP SCREW
18	4	54277	1" – 8 HEX NUT
22	1		STICKER, FAIRBANKS PALS
23	1	17546	CONNECTOR, LIQUID TIGHT
N/S	-	21912	ANALOG BOX ASSY
N/S	-	21842	ANALOG PCB ASSY
N/S	-	73378	7" X 3/4" WEDGE ANCHOR
	4	73542	Upper Cup (1 7/8" diameter) for earlier models

## 8.2. Replacement Parts Diagram

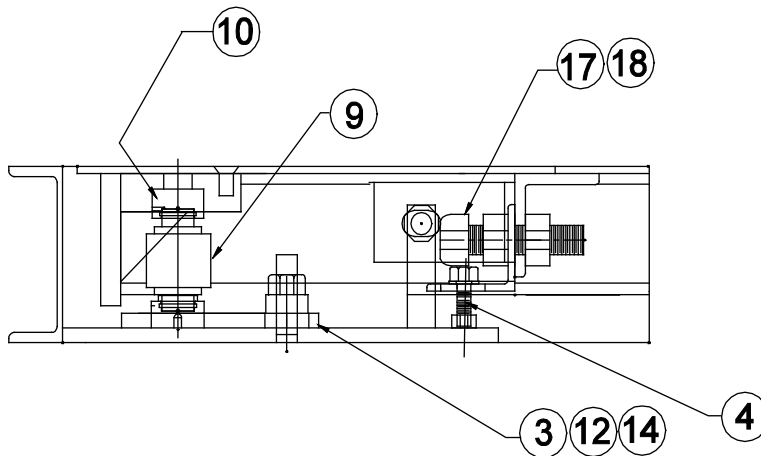
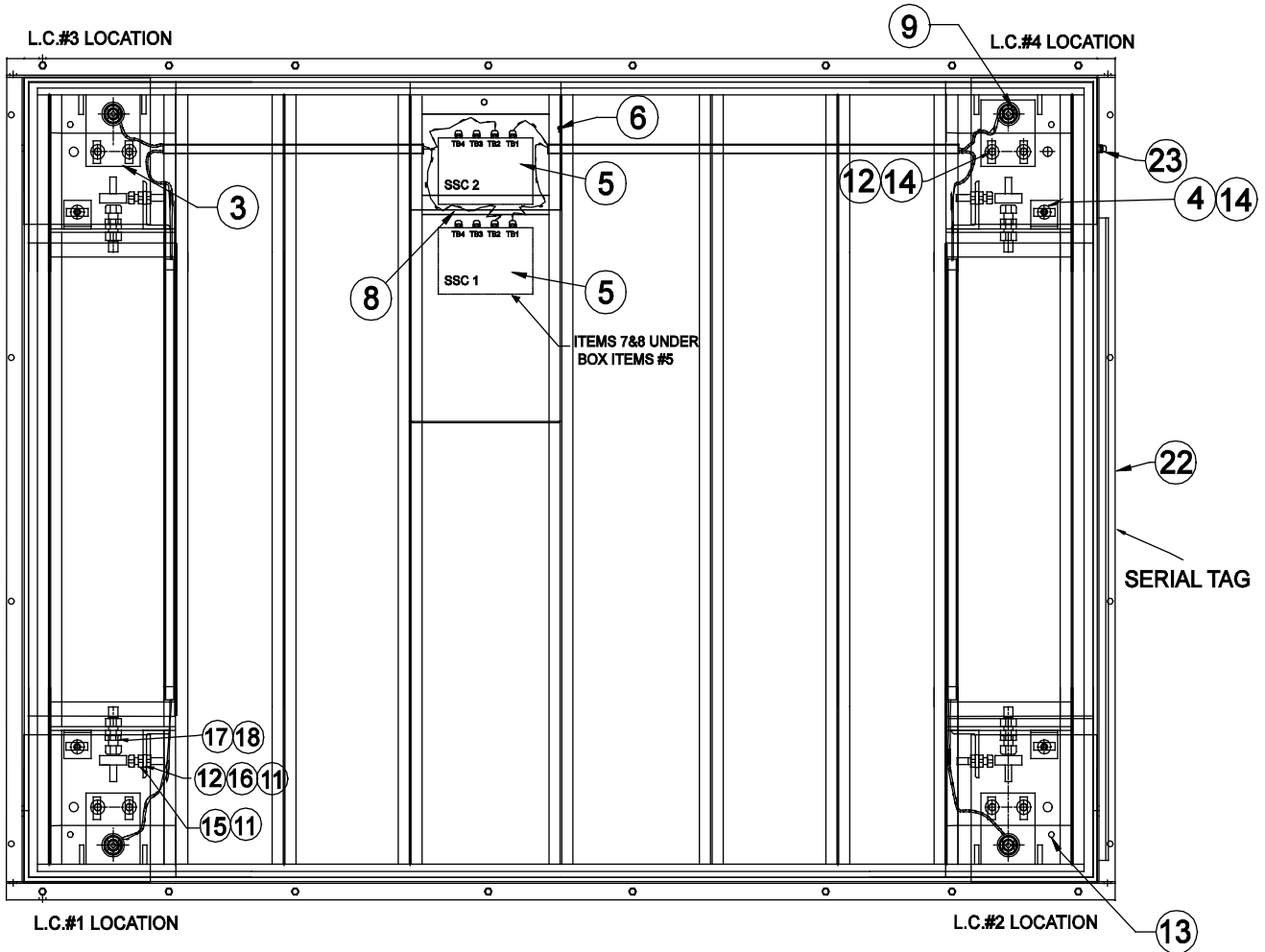

PALS WITH  
INTALOGIX SSC'S

51182-01

## 8.3. Spare Parts

### 8.3.1. Recommended Spare Parts

Part No.	Qty	Description
83669	1	Flintec Load Cell 3 ½" 50k
105718	1	Upper Cup
105786	1	Base Plate with Lower Cup

### 8.3.2. Startup / Commissioning Spare Parts

Part No.	Qty	Description
83669	1	Flintec Load Cell 3 ½" 50k
105718	1	Upper Cup
105786	1	Base Plate with Lower Cup

### 8.3.3. 2-Year Spare Parts List

Part No.	Qty	Description
83669	1	Flintec Load Cell 3 ½" 50k
105718	1	Upper Cup
105786	1	Base Plate with Lower Cup

**Capital Spare Parts** – Not Applicable

# Appendix I: Wiring Diagrams

## A. PALS Intalogix Digital Wiring

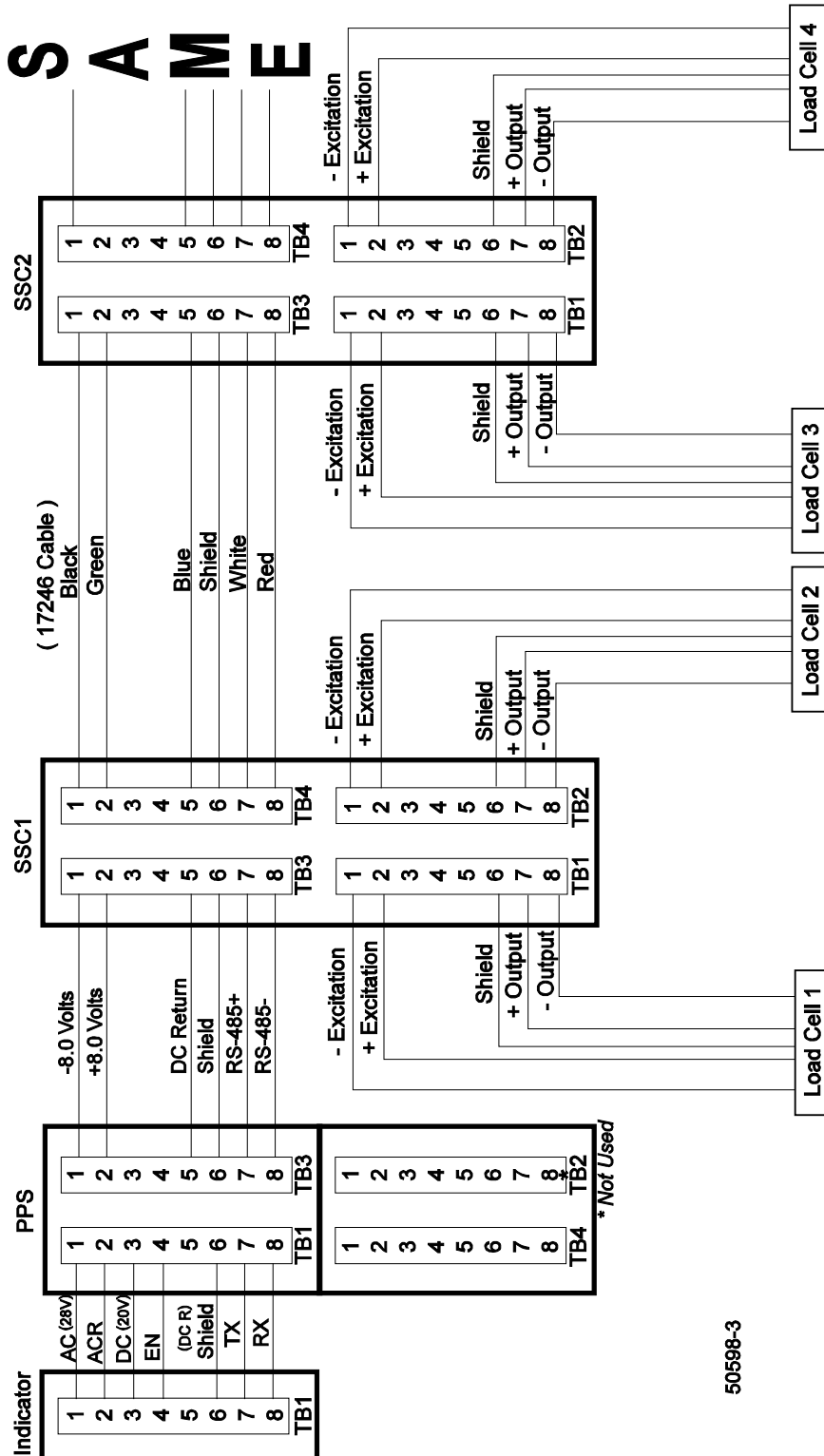

50598-3



## B. PALS Analog Wiring

The platforms are shipped fully assembled and wired. Wire the interface cable to the instrument according to this chart.

L/C Wire Color	Function	Analog Instrument
Black	(-) Excitation	(-) Excitation
Green	(+) Excitation	(+) Excitation
Yellow	Shield	Shield
White	(+) Signal	(+) Signal
Red	(-) Signal	(-) Signal

---

**NOTE:** Refer to the proper instrument service manual for proper installation, programming, and calibration of the instrument.

---

### Wiring Chart

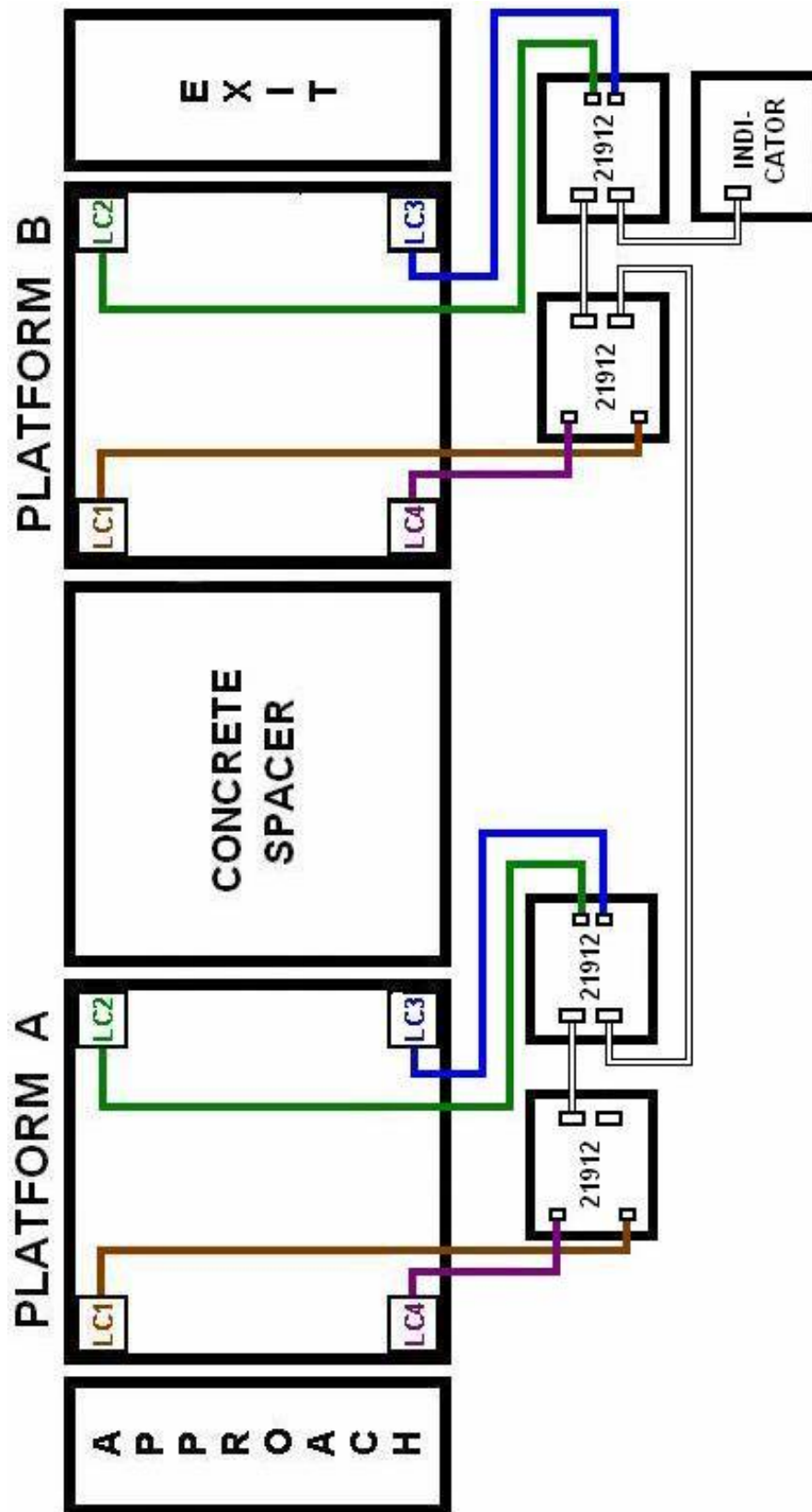



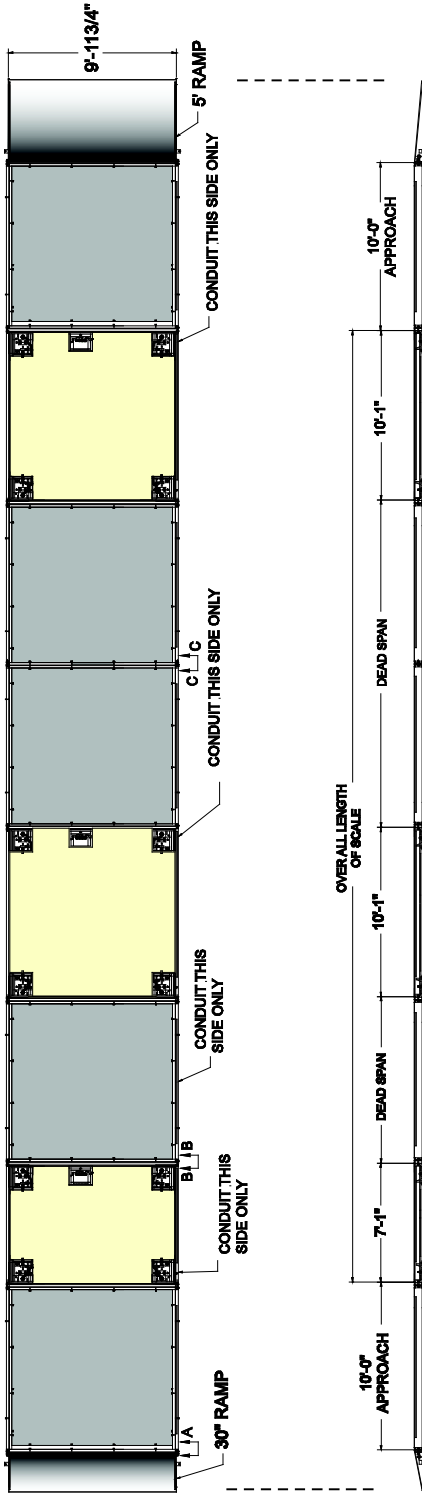

ELEVATION VIEW

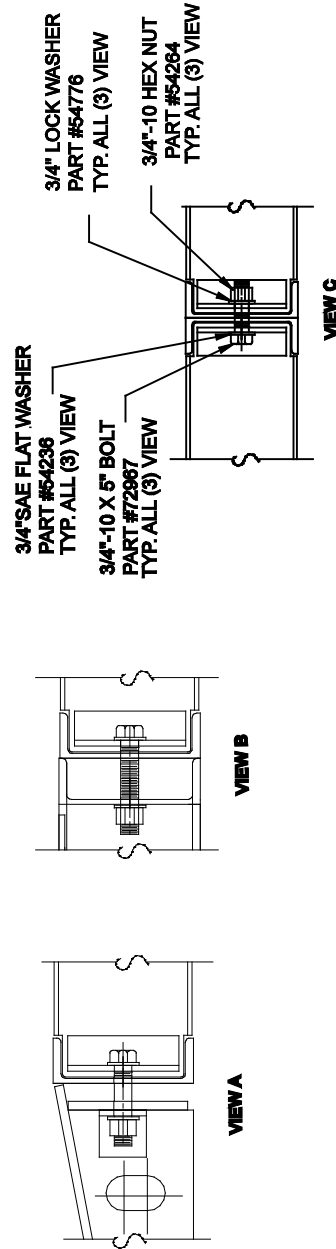

FRAME FILL CONCRETE REQUIREMENTS	
f <sub>c</sub> =3500 P.S.I.	
AREA	QUANTITIES
10 FT. LG. APPROACH	2 CU. YD.
DEAD SPAN	0.2 CU. YD. PER LINEAR FT.

NOTE:  
 DEAD SPANS MAY BE COMPRISED OF A SINGLE  
 OR MULTIPLE FRAMES.  
 THIS CONNECTION ONLY  
 AVAILABLE IF DEAD SPAN IS 14' OR LONGER.

TYPICAL EXAMPLE  
 OF A  
 SETTING PLAN  
 MATRIX-7-10-10-SD  
 51182-03

# Appendix III: Shim Dimensions

- Advised thickness for shims is 1/8", 1/4", or 1/2". Shims greater than 1/2" are not approved for use with PALS & Matrix systems.

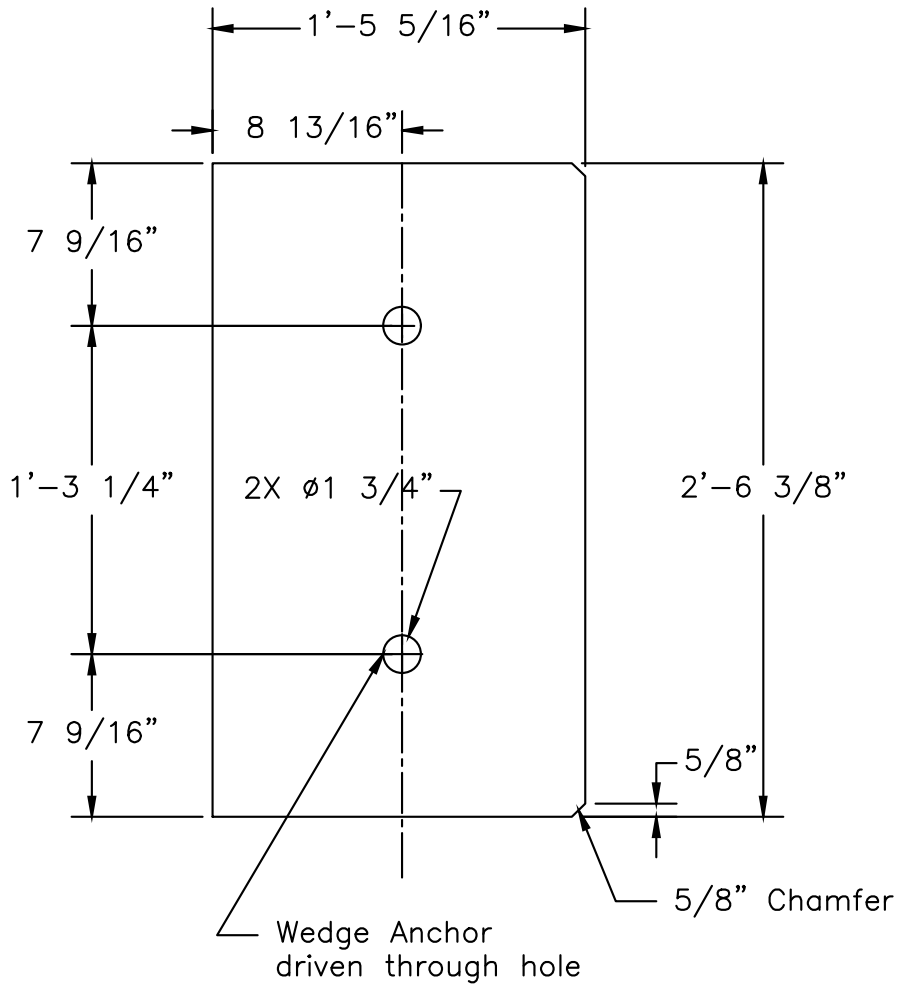

Shim for end sections

- This plate is compatible with the corner plates for the end sections of the scale as indicated on the setting plan. This is designed to shim two frames with the notched corner pointed towards the center of the platform.

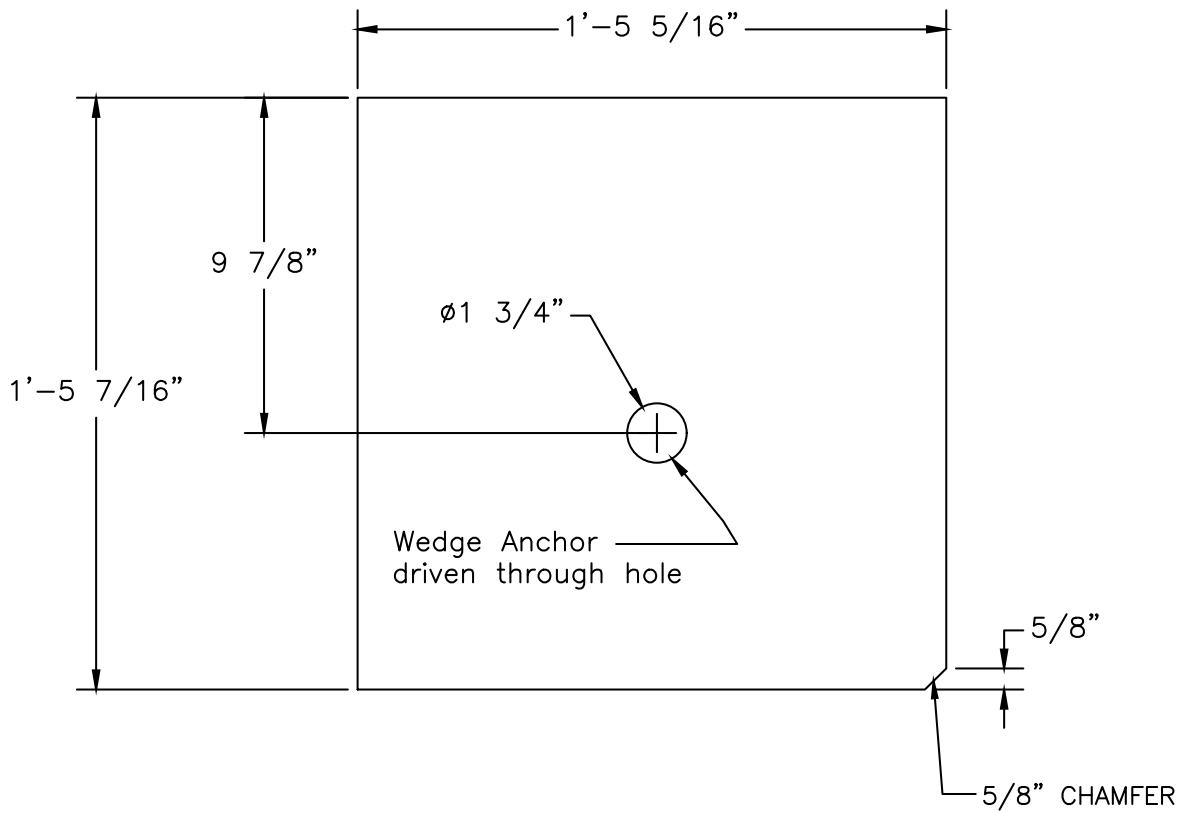



Manufactured by Fairbanks Scales, Inc.

[www.fairbanks.com](http://www.fairbanks.com)

# **PALS & Matrix Scale**

---

**Highway Scale System**  
**Installation Manual 51182**