

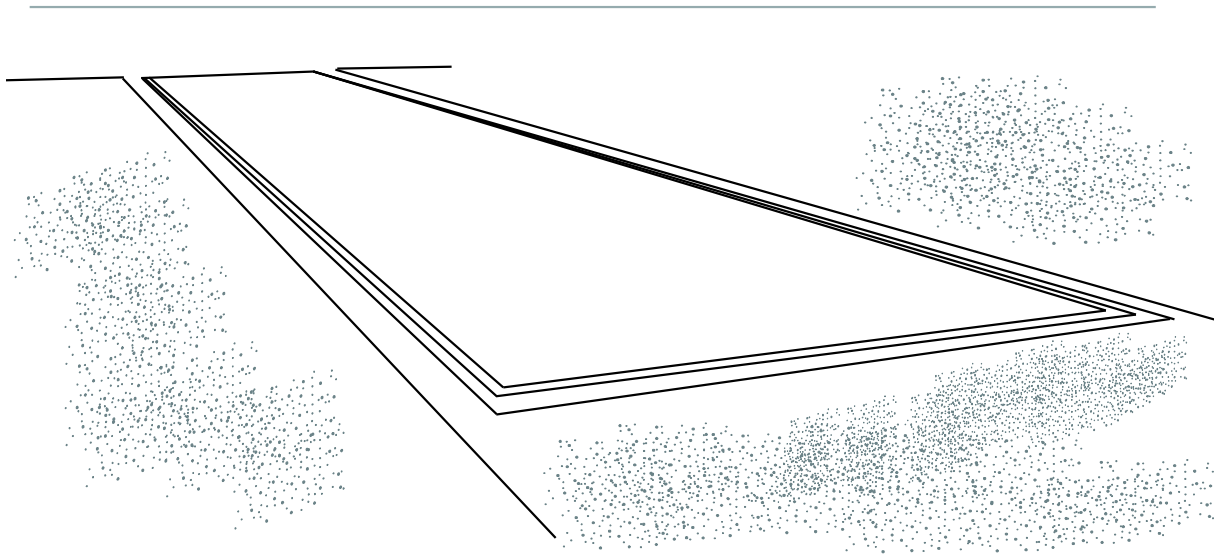

**INSTALLATION MANUAL**

# **Tundra Series**

## **Truck Scale**



**51353**

**Revision 5 10/18**



## **Disclaimer**

Every effort has been made to provide complete and accurate information in this manual. However, although this manual may include a specifically identified warranty notice for the product, Fairbanks Scales makes no representations or warranties with respect to the contents of this manual, and reserves the right to make changes to this manual without notice when and as improvements are made.

Fairbanks Scales shall not be liable for any loss, damage, cost of repairs, incidental or consequential damages of any kind, whether or not based on express or implied warranty, contract, negligence, or strict liability arising in connection with the design, development, installation, or use of the scale.

**© Copyright 2018**

This document contains proprietary information protected by copyright. All rights are reserved; no part of this manual may be reproduced, copied, translated, or transmitted in any form or by any means without prior written permission of the manufacturer.

# Amendment Record

## Tundra Series Truck Scale

Installation Manual  
Document 51353

Manufactured by Fairbanks Scales, Inc.  
821 Locust Street  
Kansas City, MO 64106

Created	10/2014	Created
Revision 1	11/2014	New Documentation Release
Revision 2	12/2015	Updated Parts section, added p/n 161197
Revision 3	01/2016	Updated Parts > Load Cells and Hardware section
Revision 4	10/2016	Updated Scale Installation > Replacing the Locator Tools with Load Cells
Revision 5	10/2018	Added Spare Parts Lists

---

# TABLE OF CONTENTS

---

<b>SECTION 1: GENERAL INFORMATION.....</b>	<b>6</b>
<b>1.1. Scale Descriptions .....</b>	<b>6</b>
<b>1.2. Scale Applications .....</b>	<b>6</b>
<b>1.3. Component Descriptions.....</b>	<b>7</b>
1.3.1. <i>Weighbridge.....</i>	7
1.3.2. <i>Deck.....</i>	7
1.3.3. <i>Scale Pit.....</i>	8
1.3.4. <i>Smart Sectional Controllers (SSCs) .....</i>	8
1.3.5. <i>Load Cells.....</i>	9
<b>1.4. Component Specs.....</b>	<b>10</b>
1.4.1. <i>Load Cell Specifications .....</i>	10
1.4.2. <i>Platform Specifications .....</i>	10
<b>1.5. Options.....</b>	<b>11</b>
<b>1.6. Accessories .....</b>	<b>11</b>
<b>SECTION 2: COMPANY SERVICE INFORMATION .....</b>	<b>12</b>
<b>2.1. General Service Policy .....</b>	<b>12</b>
2.1.1. <i>Service Technician's Responsibilities.....</i>	13
2.1.2. <i>Users' Responsibility .....</i>	13
<b>SECTION 3: PRE-INSTALLATION .....</b>	<b>14</b>
<b>3.1. Conferring with Our Client .....</b>	<b>14</b>
<b>3.2. Pre-Installation Checklist .....</b>	<b>14</b>
<b>3.3. Unpacking.....</b>	<b>15</b>
3.3.1. <i>Physical Installation Notes.....</i>	16
<b>3.4. Tools, Equipment and Materials .....</b>	<b>16</b>
3.4.1. <i>Measuring, Testing &amp; Checking Equipment .....</i>	16
3.4.2. <i>Assembly Tools .....</i>	17
3.4.3. <i>Materials .....</i>	17
<b>3.5. Precautions.....</b>	<b>19</b>
3.5.1. <i>Welding.....</i>	19
3.5.2. <i>Load Cell Installation Precautions .....</i>	20
3.5.3. <i>Load Cell Handling .....</i>	20
<b>3.6. Site Inspection.....</b>	<b>21</b>
3.6.1. <i>Pit/ Foundation.....</i>	21
3.6.2. <i>Scale House .....</i>	21
<b>SECTION 4: SCALE INSTALLATION.....</b>	<b>22</b>
<b>4.1. Standard Installation Steps .....</b>	<b>22</b>
<b>4.2. Inspecting the Contractor's Pit Construction.....</b>	<b>23</b>
<b>4.3. Weighbridge Section Assembly.....</b>	<b>23</b>
4.3.1. <i>Proper Bolt Torque .....</i>	24
4.3.2. <i>Torque Chart.....</i>	25
<b>4.4. Moving the Assembled Sections .....</b>	<b>26</b>
<b>4.5. Installing Base Plates, and Locator Tools .....</b>	<b>27</b>
<b>4.6. Completing Scale Construction.....</b>	<b>28</b>
<b>4.7. Concrete Deck Forming and Pouring.....</b>	<b>31</b>
<b>4.8. Replacing the Locator Tools with Load Cells.....</b>	<b>32</b>



- 4.9. Mounting the Weighbridge Components ..... 33**
  - 4.9.1. *SSC, PPS, or Balance Box Mounting*..... 33
- SECTION 5: ELECTRICAL INSTALLATION ..... 34**
- 5.1. Wiring Information ..... 34**
  - 5.1.1. *Maximum Cable Lengths*..... 34
- 5.2. Electronic Component Care ..... 34**
  - 5.2.1. *Protection Against Hostile Environments* ..... 35
  - 5.2.2. *Tightening O-rings* ..... 36
- 5.3. Load Cell Numbering ..... 37**
- 5.4. Smart Sectional Controller (SSC) to Load Cell Wiring ..... 38**
  - 5.4.1. *RC Load Cell Wiring* ..... 38
- 5.5. Power Supply Wiring ..... 39**
- 5.6. Instrument to Pit Power Supply Cable Connection ..... 40**
- 5.7. Grounding the Scale ..... 41**
- 5.8. Instrument and Accessories. Test and Calibration..... 42**
- SECTION 6: SERVICE & MAINTENANCE..... 43**
- 6.1. Recommended Preventive Maintenance Schedule..... 43**
  - 6.1.1. *Monthly* ..... 43
  - 6.1.2. *Every six (6) months*..... 43
- 6.2. Component Replacement Steps ..... 44**
  - 6.2.1. *Rocker Column Load Cell Replacement* ..... 44
- 6.3. Component Replacement Steps, Continued ..... 45**
  - 6.3.1. *SSC Board Replacement*..... 45
  - 6.3.2. *Pit Power Supply PC Board Replacement* ..... 45
- SECTION 7: PARTS ..... 46**
- 7.1. Load Cells and Hardware ..... 46**
- 7.2. Spare Parts Lists ..... 47**
  - 7.2.1. *Recommended Spare Parts* ..... 47
  - 7.2.2. *Startup / Commissioning Spare Parts* ..... 47
  - 7.2.3. *2-Year Spare Parts List* ..... 47
- APPENDIX I: INTALOGIX™ WIRING ..... 48**
- APPENDIX II: FOUNDATION CHECK LIST ..... 50**
- APPENDIX III: PRECAST CONCRETE DECK SPECIFICATIONS ..... 52**

---

# SECTION 1: GENERAL INFORMATION

---

## 1.1. Scale Descriptions

The **Tundra Truck Scale** is a fully electronic Pit Type Truck Scale. This field-assembled unit has a pour-in-place concrete deck. Concrete approaches are also required according to **H44 Standards**.

## 1.2. Scale Applications

Asphalt & concrete plants  
Dairy farms  
High volume applications  
Timber Mills

Aggregate yards  
Farmer's markets  
Landfills  
Transfer stations

Coal mines  
Grain plants  
Ports of entry  
Transportation companies



## 1.3. Component Descriptions

### 1.3.1. Weighbridge

The weighbridge is constructed of structural steel beams which bolt together. The weighbridge is supported by the load cells and bearing plates and includes checking devices to limit excessive longitudinal and lateral platform movements.

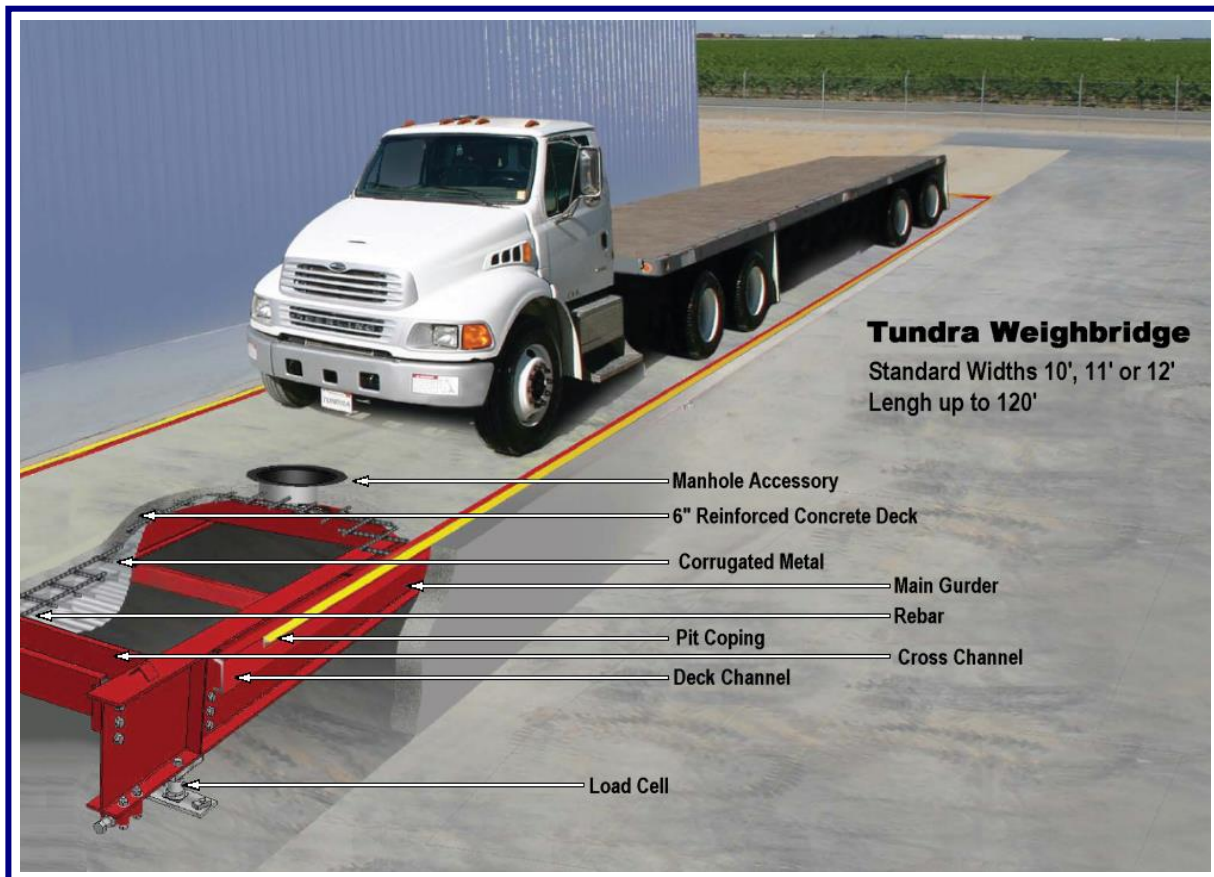

### 1.3.2. Deck

The platform deck is constructed of reinforced concrete, as detailed on the **Certified Drawing Specifications**.

- The concrete deck is **six inches (6") thick**.
- Concrete is typically poured over corrugated steel, which rests on the weighbridge and is contained by a steel channel frame.
- One or more manholes may be provided for access to the scale pit (optional).

### 1.3.3. Scale Pit

The scale pit is constructed of reinforced concrete as detailed on the **Certified Drawing Specifications**.

The Tundra Scale requires a four foot (4') or deeper foundation.

- ✓ Some states require a minimum of four feet (48") pit depth. Consult with the local W&M for specifics in your area.

The pit includes correctly positioned piers with level surfaces for RC type load cell base plates.

The ground rod(s) should be installed before the pit floor is poured.



This System uses **Intalogix™ Technology**, and requires two (2) pit ground rods.

### 1.3.4. Smart Sectional Controllers (SSCs)

The Smart Sectional Controllers (SSCs) used on **Intalogix™ Applications** are mounted at each section using the supplied self-tapping screws and should be placed on the cross members at installation.

Each Sectional Controller has four (4) water-tight gland bushings for cables.

The Pit Power Supply(ies) are mounted in the same manor.

- ✓ Wiring diagrams for Sectional Controller(s) and Pit Power Supply(ies) are in *Appendix I*.





### 1.3.5. Load Cells

The load cells directly support the weighbridge. The Tundra Truck Scale uses the **Rocker Column (RC)** type Load Cell.

- ✓ The RC cells are **4 11/16" tall**.
- ✓ The Load Receiver is free-floating design.
- ✓ The platform is free to move within the clearances provided by adjustable checking.
- ✓ With weight applied or empty, the platform must stay in, or return to the original position.
- ✓ The load cells are calibrated with the cable attached, and therefore ***the cable should NOT be cut.***
- ✓ Load cells and sections are adjusted within the **Intalogix™ Equipment Instrument**.

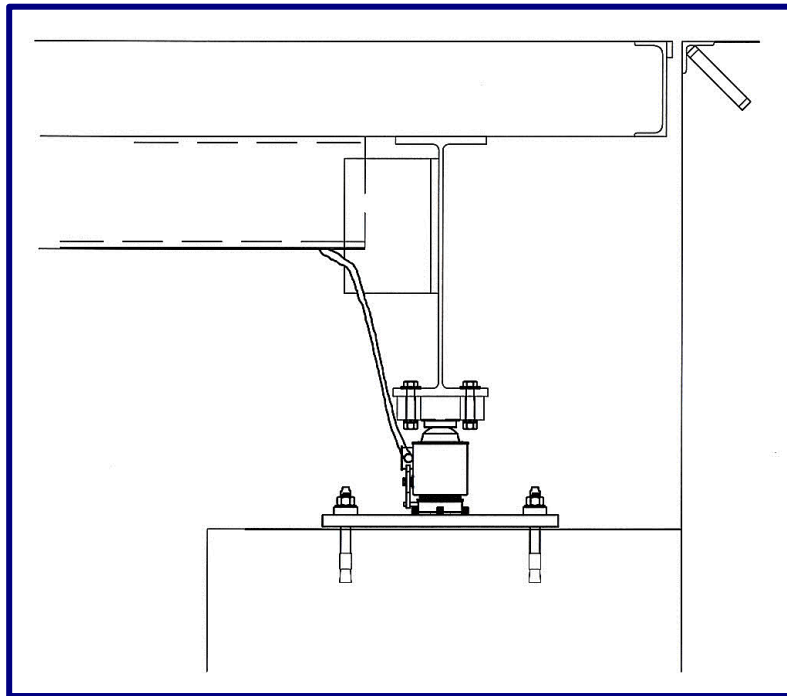

## 1.4. Component Specs

### 1.4.1. Load Cell Specifications

Capacity	<b>66,000 lbs.</b>
Type	<b>4 1<sup>1</sup>/<sub>16</sub>" Stainless Steel Rocker Column (RC Cells)</b>
Sealing	<b>Glass-to-Metal Connection Points, complete hermetic sealing; cable entry sealed by four (4) water-tight gland bushings</b>
Material	<b>Stainless Steel</b>
Rating	<b>NEMA 6P (IP68 / 69K)</b>
Resistance	<b>1,000 Ohms</b>
Operating Temperature	<b>-10 to +40°C (-14 to 104°F)</b>
Output	<b>2.4 mv/v</b>
Combined Error	<b>≤0.02%</b>
Zero Balance (FSO)	<b>1.0%</b>
Excitation	<b>5 to 15 VDC</b>
Ultimate Overload	<b>300%</b>
Cable Length	<b>15'</b>
Cable Protection	<b>Stainless Steel Sheathing</b>
Approvals	<b>NTEP CC# 14-024 Factory Mutual (FM) Approved</b>

### 1.4.2. Platform Specifications

Deck Dimensions	<b>Widths: 10', 11' and 12' Standard Lengths: 10' to 120' Standard — Custom sizes also available.</b>
Scale Capacity	<b>45 tons to 135 tons</b>
CLC	<b>60,000 and 100,000 CLC</b>
Load Cell Capacity	<b>66,000 lbs.</b>
Sections	<b>2 thru 7</b>
Deck Construction	<b>Field Pour Concrete</b>
Module Construction	<b>Structural Steel</b>
Deck Thickness	<b>6" thick</b>
Approval	<b>NTEP CC# 94-101</b>

## 1.5. Options

- Dump through deck
- Factory assembled with factory poured concrete deck
- Steel deck
- Structural grating
- CLC up to 100,000
- Custom design to fit existing foundations
- Galvanized weighbridge

## 1.6. Accessories

- Remote weight displays
- Intrinsically safe electronics
- Ticket printers
- Manholes
- Instrumentation
- Remote terminal
- Traffic signals



---

## SECTION 2: COMPANY SERVICE INFORMATION

---

### 2.1. General Service Policy

Prior to installation, *always* verify that the equipment satisfies the customer's requirements as supplied, and as described in this manual.



If the equipment cannot satisfy the application and the application cannot be modified to meet the design parameters of the equipment, **the installation should NOT be attempted.**

It is **the customer/operator's responsibility** to ensure the equipment provided by Fairbanks is operated within the parameters of the equipment's specifications and protected from accidental or malicious damage.

## WARNING!

**Absolutely NO** physical, electrical or program **modifications** other than selection of standard options and accessories can be made by customers to this equipment

Repairs are performed by Fairbanks Scales Service Technicians and Authorized Distributor Personnel ONLY!

*Failure to comply with this policy voids all implied and/or written warranties*

### 2.1.1. Service Technician's Responsibilities

- ✓ All electronic and mechanical calibrations and/or adjustments required for making this equipment perform to accuracy and operational specifications are considered to be part of the original installation.
  - They are included in the installation charge.
  - Only those charges which are incurred as a result of the equipment's inability to be adjusted or calibrated to performance specifications may be charged to warranty.
- ✓ The equipment consists of printed circuit assemblies which must be handled using ESD handling procedures, and must be replaced as units.
  - Replacement of individual components is not allowed.
  - The assemblies must be properly packaged in ESD protective material and returned intact for replacement credit per normal procedures.



### 2.1.2. Users' Responsibility

- ✓ **Absolutely no physical, electrical or program modifications other than selection of standard options and accessories are to be made to this equipment.**



---

## SECTION 3: PRE-INSTALLATION

---

### 3.1. Conferring with Our Client

The technician must be prepared to recommend the arrangement of components which provide the most efficient layout, utilizing the equipment to the best possible advantage.

Assist the customer in selecting a site which allows easy access to and from the scale, ensuring enough area for straight and level approaches, and to meet all **State and Local Weights and Measures Regulations**.

- Smooth and level approaches are required at each end of the platform to reduce loading shock, and to facilitate testing of the scale.
- The site needs good drainage away from the scale, elevated enough so the surrounding areas **drain away from the scale**.
- Obtain all the necessary permits and licenses prior to beginning construction.
- In the absence of such laws, the approaches must conform to paragraph UR.2.6 of the **National Institute of Standards and Technology Handbook 44**, which states that the first 10 feet must be level and on the same plane as the scale platform.

The platform should be visible from the instrument location.

- Surface water must drain easily, and not collect, under the scale.

Explain and review the warranty policy with the customer.

### 3.2. Pre-Installation Checklist

The following points should be checked and discussed with the **Area Sales Manager and/or customer**, if necessary, before the technician goes to the site and installs the equipment.

- ✓ Check the customer's application to make certain it is within the capabilities and design parameters of the equipment.
- ✓ If the installation process might disrupt normal business operations, tell the customer and ask that they make ample arrangements.
- ✓ The service technician reviews the recommended setup with the Area Sales Manager or Area Service Manager, and together they identify all necessary variations to satisfy the customer's particular application.



### 3.3. Unpacking



All beams and channels come in banded bundles.

**Follow these guidelines when unpacking all equipment.**

- ✓ Check in all components and accessories according to the customer's order.
- ✓ Remove all components from their packing material, checking against the invoice that they are accounted for and not damaged.
  - Advise the shipper immediately, if damage has occurred.
  - Keep the shipping container and packing material for future use.
  - Order any parts necessary to replace those which have been damaged.
  - Check the packing list.

The **CUSTOMER** is the **receiving party** if the equipment was **shipped to the Customer's address**.

**FAIRBANKS** is the **receiving party** if the equipment was **shipped to the Fairbanks Service Center**.

- ✓ Collect all necessary installation manuals for the equipment and accessories.
- ✓ Open the equipment and perform an inspection, making certain that all hardware, electrical connections and printed circuit assemblies are secure.
- ✓ Do not reinstall the cover if the final installation is to be performed after the pre-installation checkout.
- ✓ Do not load the platform if there is any evidence of damage to the platform or supporting structure.

### **3.3.1. Physical Installation Notes**

- ✓ Before *installation*, check that all components are in good condition.
  - If damage occurs due to shipping, order the new part or component immediately.
- ✓ Only those charges which are incurred as a result of the equipment's inability to be adjusted to performance specifications may be charged to warranty.
- ✓ No physical alterations (mounting holes, etc.) are allowed during installation.

---

**IMPORTANT NOTE:** *The installing technician is responsible that all personnel are fully trained and familiar with the equipment's capabilities and limitations before the installation is considered complete.*

---

## **3.4. Tools, Equipment and Materials**

*The following tools, equipment and materials are suggested to be on hand before the installation begins.*

### ✓ **Certified Project Drawing Specifications**

#### **3.4.1. Measuring, Testing & Checking Equipment**

- ✓ Surveyor's Transit and Rod
- ✓ Plumb Bob
- ✓ Stringline and a chalkline
- ✓ 50 to 100' steel tape measure.
- ✓ Machinist's Levels (**Starrett #134 & 132-6**)
- ✓ Carpenter's Level
- ✓ Multimeter





### 3.4.2. Assembly Tools

✓ **A mobile crane**

- Four equal length twenty foot (4-20 ft.) lifting chains or cables *with hooks*.

---

**IMPORTANT NOTE:** *The installer **MUST** reserve Crane and Chains/Cables in advance from a local rental service company.*

---

- ✓ Hand tools
- ✓ Hydraulic jacks
  - Two – twenty ton (2–20 ton) jacks

Load Cell Locating Tools, **one for each load cell**, available for purchase through **Fairbanks Customer Service**

- ✓ Come-Along (1-Ton min.)
- ✓ 2 - Sledge Hammers (5 & 10 lb.)
- ✓ Claw Hammer
- ✓ 6' Pinch Bar
- ✓ 3' Crow Bar
- ✓ Drift Pins
- ✓ Torque or Impact Wrenches (500 ft. lb.)
- ✓ Open End Wrench
- ✓ Adjustable Crescent or Monkey Wrench
- ✓ Trowels (2)
- ✓ Pipe Wrench



### 3.4.3. Materials

Quality vehicle wheel bearing grease

Anti-seize

- Found at local **Automotive Parts & Supply** retailer.



★ ★ **IMPORTANT INSTALLATION NOTICE** ★ ★

- ✓ All communications which utilize RS232 Serial Cable *must be limited to fifty (50') feet.*
- ✓ All load cells, load cell cables and interconnecting cables used to connect all scale components shall be located **a minimum of thirty-six (36") inches distance away** from all single and multiple phase high energy circuits and electric current carrying conductors.

*This includes digital weight instruments, junction boxes, sectional controllers, and power supplies.*

*This includes any peripheral devices, such as printers, remote displays, relay boxes, remote terminals, card readers, and auxiliary data entry devices.*

*Also included is the scale components themselves, such as 120 volt AC, 240 volt AC, 480 volt AC and electric supply of higher voltage wiring runs and stations, AC power transformers, overhead or buried cables, electric distribution panels, electric motors, florescent and high intensity lighting which utilize ballast assemblies, electric heating equipment, traffic light wiring and power, and relay boxes.*

*All scale components, including digital weight instruments and peripheral devices are not specifically designed to operate on internal combustion engine driven electric generators and other similar equipment.*

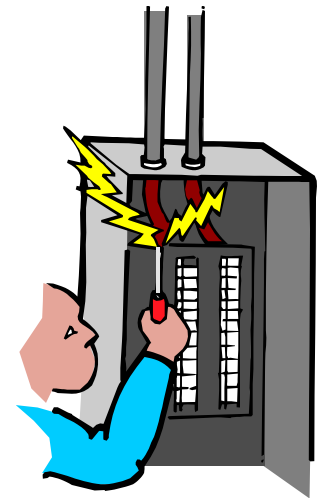

- ✓ **Electric arc welding can severely damage scale components such as digital weight instruments, junction boxes, sectional controllers, power supplies, and load cells.**
- ✓ Some digital weight instruments which Fairbanks Scales manufactures utilize RAM memory, and as a result, require a battery to maintain that memory. On such units, **if the battery is removed or becomes discharged** and the unit is unplugged from AC power, **ALL PROGRAMMED PARAMETERS INCLUDING CALIBRATION WILL BE LOST.**

---

**NOTE:** For additional information, please contact your **Fairbanks Scales Service Representative.**

---

## 3.5. Precautions

### 3.5.1. Welding

*If arc welding or cutting is required during any stages of weighbridge and deck installation, prevent currents from damaging the Load Cells.*

***The load cell cable must be disconnected.***

- ✓ Removal of the load cells is recommended.
- ✓ The load cells cable terminations must not be allowed to touch any part of the weighbridge, pit steel or each other. Insulate each cable lead.
- ✓ The load cell cables should be coiled up and kept as far as possible from any steel.
- ✓ The arc welder ground connection should be made as close as possible to the weld location.
- ✓ The arc welder ground must be connected so that currents DO NOT pass through the load cell(s).
- ✓ Do not use higher welding current than necessary.
- ✓ Protect the load cells from the heating and splattering effects of welding.



### **3.5.2. Load Cell Installation Precautions**

Correct installation of the load cells is the most critical factor in fully electronic scale assembly. Perfect load cell installation will frequently compensate for other intolerances.

#### **Elevation**

The load cell must be installed on piers formed to the specific elevation.

#### **Plumb**

Each RC load cell must be installed so that it is plumb, to assure loading through the direct center axis.

#### **Support**

When adjustments are complete, the load cell base plates must be fully supported before any traffic is allowed on the scale.

#### **Equal Loading**

Load Cell shims may be required at one or more cells to ensure equal weight distribution upon each load cell.

### **3.5.3. Load Cell Handling**

Load cells must be handled with care to avoid being damaged during installation. Refrain from the following:

- ✓ Rough handling, which can be avoided with care.
- ✓ Voltage surges, which can be minimized by surge voltage protection.
- ✓ Welding currents must be avoided by disconnecting or completely removing the cells during all welding operations.
- ✓ Dampness can damage the scale's electronic components. The cell and/or cable must not contact standing water.
- ✓ All load cells must be installed correctly, plumb, level and square.
- ✓ Overloading the scale.

## 3.6. Site Inspection

*Before accepting the completed work of the contractor, check the following points.*



### 3.6.1. Pit/ Foundation

All concrete work **MUST** conform to standards set forth by the **American Concrete Institute Code**.

- ✓ Measure the pit/ foundation dimensions carefully, then compare those figures with the **Fairbanks Certified Drawings**. If there are **ANY** discrepancies, contact the construction contractor **IMMEDIATELY**. Use Appendix II Foundation Checklist.
- ✓ The pit floor must be constructed so that no standing water accumulates.
- ✓ The approaches must be of correct height and level with the top of the pit wall.
- ✓ Check for correct pier elevation and for smooth, even tops.
- ✓ Check that a proper sized conduit is provided through the pit wall, below the frost line, at the location nearest the scale house and instrumentation.
- ✓ If AC power is required in the pit, for lighting or for a pump, the line must be in a separate, 1" conduit, at least 36" from the weight signal cable conduit.
- ✓ Check that the scale pit ground rods are installed in the correct location and project through the pit floor to the correct height. The scale pit ground rods must be driven into the earth at the bottom of the pit and tied to the rebar before the floor is poured. This assures the easiest installation and deepest possible penetration.

### 3.6.2. Scale House

Install the **Surge Voltage Protection Outlet Box (11341)**.

It is recommended that the Instrument is on a dedicated circuit with a separate circuit breaker.

The Instrumentation should not be subject to direct sunlight, or in environmental conditions for which it is not intended.

---

**NOTE:** See **Appendix II** for *Foundation Checklist*.

---

---

## **SECTION 4: SCALE INSTALLATION**

---

### **4.1. Standard Installation Steps**

*Listed below are the steps to a standard scale installation.*

- A. Inspecting the Contractor's Pit Construction.
- B. Install the End Wall Check Brackets.
- C. Weighbridge Section Assembly.
- D. Move Assembled Sections into the Pit.
- E. Complete the Weighbridge Construction.
- F. Concrete Deck Forming and Pouring.
- G. Replace the Locating Tools with Load Cells.
- H. Wire the Weighbridge Components.
- I. Install and Wire the Instrument and any Accessories, then calibrate and test the scale.



## 4.2. Inspecting the Contractor's Pit Construction

Inspect the work site; including the pit, scale house, all poured concrete, approaches and exits, anchor bolt placements, and all measurements against the **Certified Drawing Specifications**.

- ✓ See Foundation Inspection Checklist in Appendix II of this manual.
- ✓ Upon the removal of the forms and backfill, check for proper drainage. A slope away from the scale is *mandatory*.

CAUTION!

**Each Module Assembly is extremely heavy.**

- ✓ **Handle with great care to prevent injury.**
- ✓ **Always let the crane do the lifting.**
- ✓ **Use cross pieces and blocking to prevent steel tipping over.**

## 4.3. Weighbridge Section Assembly

**Assemble each of the Weighbridge frame sections on a flat surface near the pit.**

1. With a crane, lay out the two (2) Main Frame I-beams of the first section parallel onto a flat surface near the pit.
2. Position the cross channel between the two Main Frame I-beams.
3. Coat bolts thoroughly with anti-seize, then fasten the Main Frame I-beams together loosely.
4. Place the rest of the cross channels into their upper and lower position, bolting them together loosely.
5. Cross square the top and ends of the weighbridge assembly, then snug all the bolts.
6. Continue with this method until all the sections are completely assembled *outside* the Pit.

If the **scale is eleven feet (11') or wider**, install the outriggers.



7. Assemble the Checking Bracket Bumper Bolt to the End Girders





### **4.3. Weighbridge Section Assembly, Continued**

Coat checking bolts with "anti-seize" compound.

#### **4.3.1. Proper Bolt Torque**

Tightening bolts to the proper torque is extremely important to the scale's strength and durability. Listed below describes how to determine torque level for the different rigidity of bolts.

The screw's strength and hardness is identified by markings on its head.

			
SAE 2	SAE 5	SAE 7	SAE 8

U.S. GRADE of BOLTS	2	5	7	8	SOCKET HEAD CAP SCREW
I.D. MARKS	No markings	3 lines	5 lines	6 lines	Allen head
MATERIAL	Low Carbon	Medium-carbon tempered	Medium-carbon, quenched & tempered	Medium-carbon, quenched & tempered	High-carbon, quenched & tempered
TENSILE STRENGTH (MINIMUM)	74, 000 psi	120,000 psi	133,000 psi	150,000 psi	160,000 psi

Various factors reduce the force needed to get the torque amount.

LUBRICANT OR PLATING	TORQUE CHANGES
Oil	<b>Reduce torque 15 to 25%</b>
Dry Film (Teflon or Moly-based)	<b>Reduce torque 50%</b>
Dry Wax (Cetyl Alcohol)	<b>Reduce torque 50%</b>
Chrome Plating	<b>No change</b>
Cadmium Plating	<b>Reduce torque 25%</b>
Zinc Plating	<b>Reduce torque 15%</b>



### 4.3.2. Torque Chart

#### U.S. Bolt Torque Specifications in **Ft-Lbs.**

		Grade of Bolts							
		2	2	5	5	7	7	8	8
Bolt Dia.	Thread per inch	<i>Dry</i>	<i>Oiled</i>	<i>Dry</i>	<i>Oiled</i>	<i>Dry</i>	<i>Oiled</i>	<i>Dry</i>	<i>Oiled</i>
1/4	20	4	3	8	6	10	8	12	9
1/4	28	6	4	10	7	12	9	14	10
5/16	18	9	7	17	13	21	16	25	18
5/16	24	12	9	19	14	24	18	29	20
3/8	16	16	12	30	23	40	30	45	35
3/8	24	22	16	35	25	45	35	50	40
7/16	14	24	17	50	35	60	45	70	55
7/16	20	34	26	55	40	70	50	80	60
1/2	13	38	31	75	55	95	70	110	80
1/2	20	52	42	90	65	100	80	120	90
9/16	12	52	42	110	80	135	100	150	110
9/16	18	71	57	120	90	150	110	170	130
5/8	11	98	78	150	110	140	140	220	170
5/8	18	115	93	180	130	210	160	240	180
3/4	10	157	121	260	200	320	240	380	280
3/4	16	180	133	300	220	360	280	420	320
7/8	9	210	160	430	320	520	400	600	460
7/8	14	230	177	470	360	580	440	660	500
1	8	320	240	640	480	800	600	900	680
1	12	350	265	710	530	860	666	990	740

## 4.4. Moving the Assembled Sections

1. With the crane, lift and lower the first fully-assembled Weighbridge Section into the end of the Pit.
  - Set down the section slowly onto the wooden cribbing blocks.
  
2. Using the crane, lift and lower the second fully assembled Section into the Pit. Use hydraulic jacks also to lift the assembly slightly and shift into proper alignment.



Fasten these two main girder sections together with the cross beams and hardware, using the **3/4" drift pins** to assist in aligning the plate and girder holes.

- Secure each joint tightly

Continue placing, blocking, and fastening the main girder sections until all pieces are in position.

Once *all* the sections are installed, ensure that the measurements and elevations are correct according to the **Certified Drawing Specifications**.

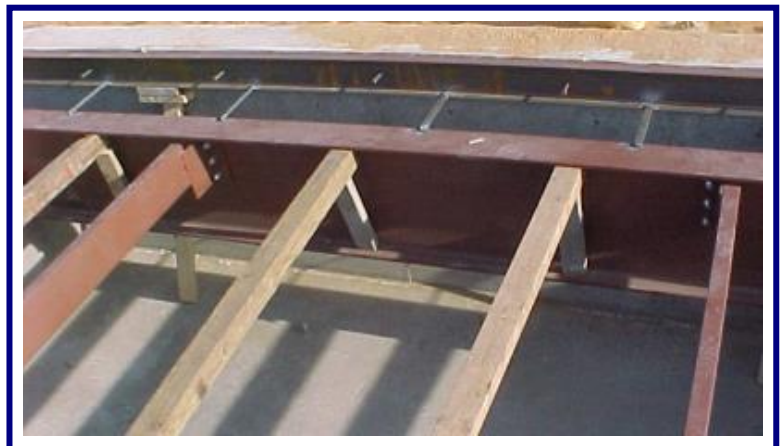

## 4.5. Installing Base Plates, and Locator Tools

1. Using the **Certified Drawing Specifications**, locate and mark the drill holes into the smooth pier top for each **Base Plate**.
2. Use hydraulic jacks to lift the weighbridge from the wooden blocks and install the Locating Tool on top of the Base Plate (*where the load cells will be located*).

When the weighbridge is set on all the Locating Tools, **Re-inspect** all locating tools are properly aligned and weighbridge is positioned correctly within the pit.

Tighten all bolts on the weighbridge.

Use a hammer-drill to make **two (2) 5/8" holes** into each .



Hammer the **Base Plate Anchors** into clean holes and tighten the nuts securely, being careful that threads are not damaged.

- Each base plate must be level and in full contact with the top of the pier.
- Adjustments can be made by chipping the concrete.
- A maximum of **+/- 1/8" space for movement** is allowed.
- Insert the **four (4) 3/8" roll pins** into each base plate for load cell retention.

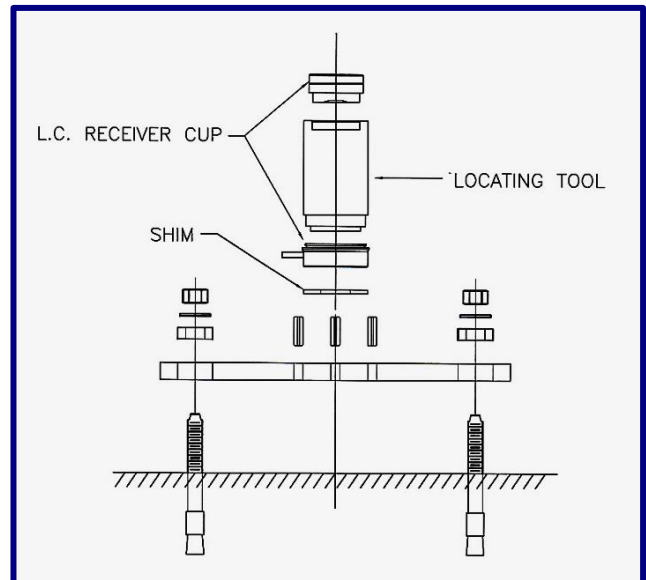

## 4.6. Completing Scale Construction

1. Install the Side check brackets.
2. Adjust all bumper bolts to touch the bumper bolt striker plates. This prevents the scale platform from moving and maintaining it in the correct position while also maintaining a plumb condition for the Locator Tools.

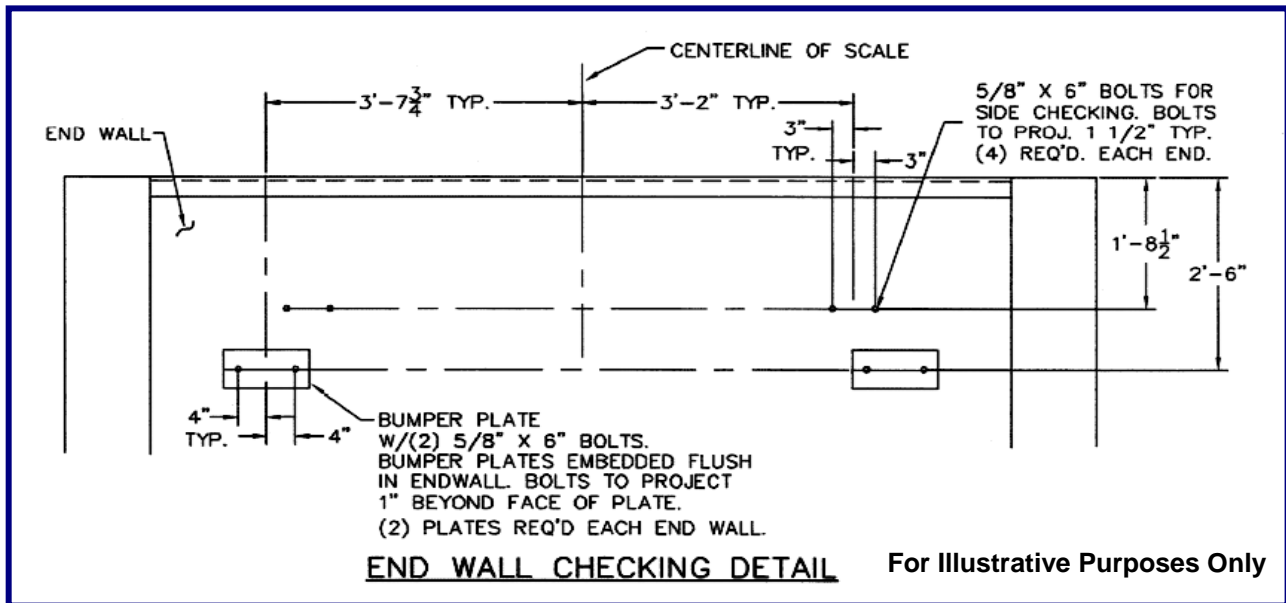

3. Lay the coping channel in position at the correct elevation and distance from the pit wall.

Weld together the butt joints of the channel. Make sure that the channel is straight and that it is welded securely.

Weld the transverse (end) coping to the main girders where they cross.

Weld nuts on *the Rock Guard* to create a **5/8" gap**.

- ✓ Space at 16-20" intervals.
- ✓ Weld flat steel straps to the bottom of the Deck Coping as needed, to space it from the pit wall, and to prevent the frame from twisting.
- ✓ See **Certified Drawing Specifications** for details.



Once the bridge is completed, install the Deck Channel flush with the Pit Coping.

## 4.6. Completing Scale Construction, Continued

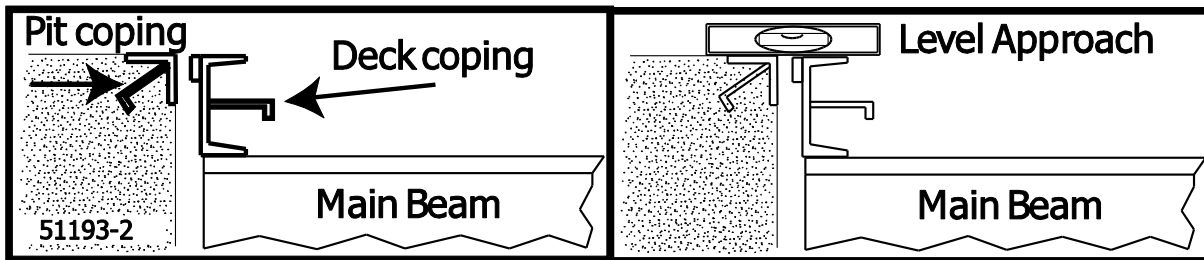

Place shoring between the main girders at intervals not to exceed **three feet (3')**.

- ✓ The wood shoring cross pieces should be 4" x 4" or 2" x 6", installed within the girder flange.



- ✓ The top of the 4" x 4" or 2" x 6" should be near to the height of the top of the girder.
- ✓ The 4" x 4" or 2" x 6" *must be* supported by a brace at each end wedged against the lower flange of the girder.



## 4.6. Completing Scale Construction, Continued

1. Lay the corrugated steel with the corrugations running parallel, down the length of the pit.

The suggested material for the deck form is galvanized corrugated sheet steel in 26 or 28 gauge thickness.

This material has corrugations on a 3-inch spacing (pitch) with a depth of  $\frac{3}{4}$ ".

This material is **NOT furnished by Fairbanks.**

2. Trim the corrugated steel as required so it will rest on the lower flange of the frame channels.
3. Cut holes for the Deck Angle Connectors in the corrugated steel, so it lays flush.



4. Place the deck reinforcing steel (rebar) as shown on the **Certified Drawings**.
5. Locate the optional manhole frame(s) and shore in position so that the cover plate(s) will be one-eighth inch ( $\frac{1}{8}$ " ) above the top of the concrete.



### Helpful Tip:

To prevent cement from seeping under the manhole, put a 55 gallon trash bag full with sand into the manhole frame(s) before pouring.

## 4.7. Concrete Deck Forming and Pouring

*The deck consists of poured reinforced concrete over corrugated sheet steel laid length-wise on the weighbridge. A channel coping surrounds the deck.*

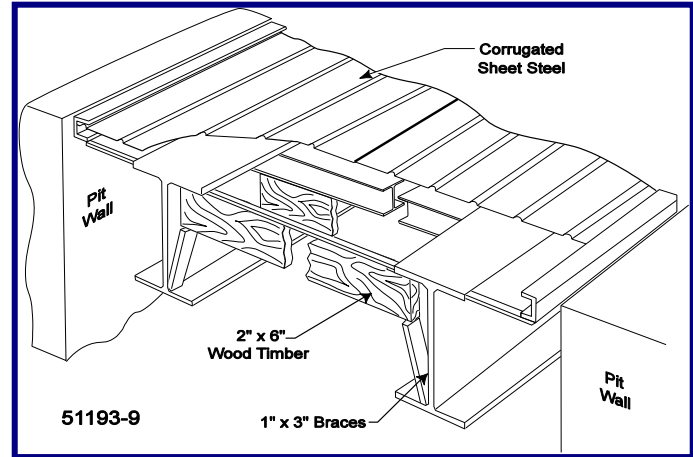

1. Pour the concrete flush with the top of the channel coping.
  - ✓ The concrete should have a minimum compressive strength of 4,000 psi.
  - ✓ Take several test cylinder samples during this process.
  
2. Place the concrete into position by direct chute method.
  - ✓ Ensure thorough consolidation by using a spud type vibrator as required.
  - ✓ All concrete work **MUST** conform to standards set forth by the **American Concrete Institute Code**.
  
3. Before the concrete has fully set, "broom" finish it with textured grooves perpendicular to the long axis of the scale.



## 4.7. Concrete Deck Forming and Pouring, Continued

# A T T E N T I O N

**The scale SHOULD NOT BE LOADED for any purpose until the core samples indicate that it is properly cured!**

4. **After the concrete is fully cured**, remove the positioning spacers (5/8" nuts), cut the corrugated to open the manhole access, and remove the wood support from the deck underside.
- ✓ The scale deck and weighbridge will now freely float.



## 4.8. Replacing the Locator Tools with Load Cells

1. Place hydraulic jack under the girder, then lift the platform so the locating tool can be removed from the upper and lower bearing cups.



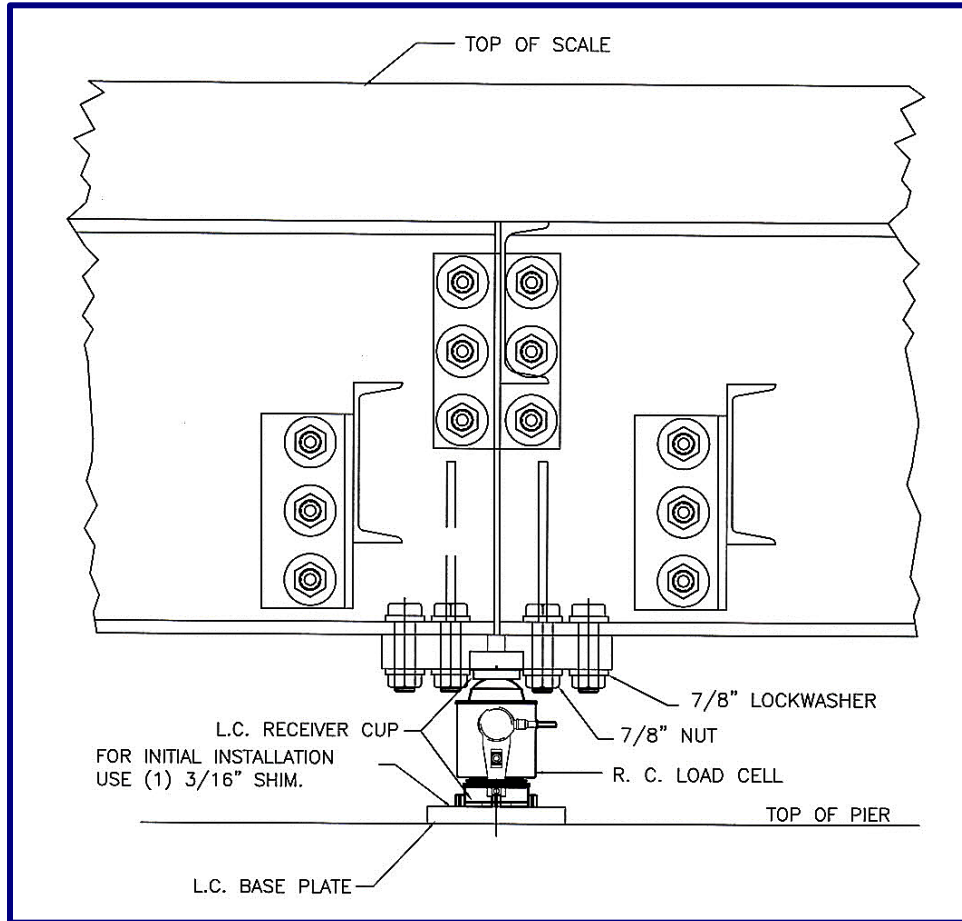

2. Install the load cell and **carefully lower the scale** (using the hydraulic jack) while seating the load cell into the cups.

---

**NOTE:** *Anti rotation must be positioned to the **INSIDE** of the scale.*

---

3. Recheck to be sure each load cell is still plumb after all load cells are installed.

## **4.9. Mounting the Weighbridge Components**

### **4.9.1. SSC, PPS, or Balance Box Mounting**

Using the supplied self-tapping screws, place the boxes at convenient locations on the cross members. **Note:** Requires 1/2" hex drive.

**Tighten securely** to provide a good electrical ground.

---

## SECTION 5: ELECTRICAL INSTALLATION

---

### 5.1. Wiring Information

- ✓ ALL wiring cable *MUST* be a minimum of 18 AWG, with individually shielded pairs.
  - Three (3) pair cable.
  - Use Fairbanks part number **17246**, or an equivalent.

#### 5.1.1. Maximum Cable Lengths

No. of LOAD CELLS 1000 Ohm Cells	Maximum Cable Lengths for INSTRUMENT-TO-POWER SUPPLY
1-10	Up to 1800 feet
12	Up to 1150 feet
14	Up to 800 feet
16	Up to 575 feet

\*\* See [Appendix I](#) for the complete wiring charts of the instrument, Power Supply ([24720](#)) and the Smart Sectional Controllers ([26168](#)).

### 5.2. Electronic Component Care

- ✓ Most of the electronic equipment consists of printed circuit assemblies, which *must* be installed using [ESD handling procedures](#).
- ✓ All electronic and mechanical adjustments are considered to be part of the installation and are included in the installation charge(s).
- ✓ The AC receptacle/outlet must be located near the Instrument and easily accessible.
- ✓ Electrical connections other than those specified may not be performed.
- ✓ The load cells are calibrated with the cable attached, and therefore *the cable should NOT be cut*.

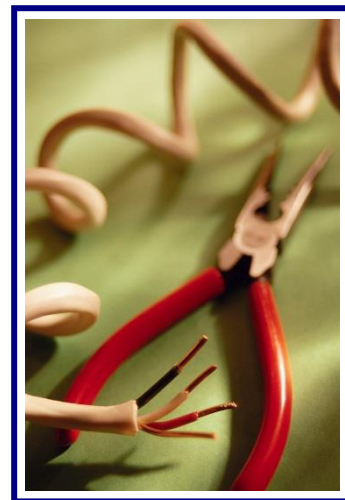

# CAUTION

**Surge voltage protection installation is effective ONLY when an adequate ground(s) is provided.**

## 5.2.1. Protection Against Hostile Environments

Tundra Scales provide protection from moisture.

- ✓ The load cells are calibrated with the cable fully attached.
- ✓ The cable connects directly to the Sectional Controller through a sealed bushing.
  - Tightened the bushings with pliers to keep water/moisture out of the box.
- ✓ **The load cell cable should NEVER be cut.**
- ✓ **Add a "drip loop" at the load cell or box entry location for all cabling.**
  - *This helps prevent water entry.*
- ✓ **Pull any free cables and wires together tightly, twist a hoop in the cables, fastening them with a zip-tie below and away from all electronic components and off the ground.**

### **5.2.2. Tightening O-rings**

Take extra care when securing **O-ring Seals**. The Wire Gland Fittings can be forced out of position if the bushing itself is not tight.

- ✓ **Do not over-tighten the bushings where they turn.**
- ✓ **Do not allow the O-ring to spin out of position when tightening the wire gland fitting.**

Follow these steps to prevent O-ring seal problems.

1. Tighten the inner nut securing the bushing in the hole.
  2. Insert cable.
  3. Carefully tighten gland with pliers until it is very snug.
- ✓ **The box covers *MUST BE* secured tightly for protection against moisture.**



### 5.3. Load Cell Numbering

**Intalogix™ Technology** installations use a specific numbering system for load cells because of digital addressing of the **SSCs**.

With respect to the following starting position, face the platform where the instrument is located.

The cell at the **upper-left** (far side) of the platform is **Cell One (1)**.

The cell positions along the **far side** have **odd cell numbers**.

The **near side** locations have **even cell numbers**.

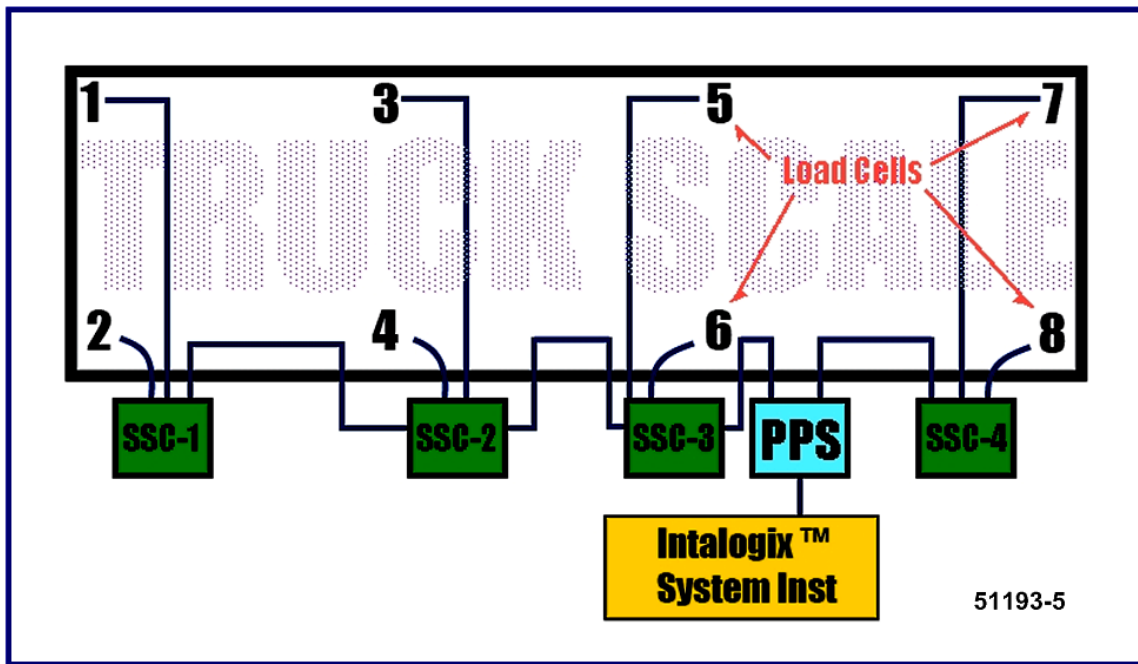

Above is an example of a four (4) section cell numberings using SSCs.

- **ODD numbered cells** are always wired to **TB1**.
- **EVEN numbered cells** are always wired to **TB2**.

## 5.4. Smart Sectional Controller (SSC) to Load Cell Wiring

Follow these steps to wire the Sectional Controller

1. Remove the nylon plug from each load cell glands being used.
2. Feed each load cell cable through the appropriate gland in the box.
3. Wire all the cells into each sections Sectional Controller.  
Also use the appropriate instrument manual for correct procedure.
4. Drain wires connect to ground lug on the Sectional Controller exterior.
5. Pull the **load cell cables** into the **Sectional Controller Box 1 (SSC1)**.
  - The **ODD numbered cell** is *always* wired to **TB1**.
  - The **EVEN numbered cell** is *always* wired to **TB2**.
  - Wire all the Smart Sectional Controllers (SSCs) and load cells as shown in **Appendix I**.
  - Load cell 'drain' wires connect to ground lug on the **Sectional Controller Box** exterior.

### 5.4.1. RC Load Cell Wiring

Terminal	Color	Description
1	Blue	(-) Excitation
2	Red	(+) Excitation
6	Yellow	Shield
7	Green	(+) Signal
8	Gray	(-) Signal



## 5.5. Power Supply Wiring

1. Bring the Home Run Cable end into the power supply box at **TB1**.
2. Dress the cable end, connect the cable to TB1 using chart in **Section 5.6**.

### If Power Supply is at Center of Scale

Follow these steps when mounting the power supply in or near the center (not at the end) of a scale.

1. Connect the SSCs on one end as shown in **Appendix I**.
2. Connect the controllers on the other end.
3. Install cables from the second center SSCs TB3(s), to the power supply at TB3 and TB4.
  - **Both TB3 and TB4 can be used to “T” off of the wiring from the center of the scale to the SSC.**

Connect the TB1 cable of the power supply to TB1 of the instrument.

Secure all gland bushing nuts with pliers

### If Power Supply is at End of Scale

Follow these steps when mounting the power supply at the end of a scale.

1. Wire all the SSC as shown in **Appendix I**.
2. Wire the last sectional controller into TB3 of the power supply.
3. Wire **TB1** of the **power supply** to **TB1** of the **instrument**.
4. Install the power supply in a protected area under the platform, near the **Home Run** cable.
  - Place it near a dedicated ground rod.
5. Run a cable from the Power Supply TB1 to the scale house.
6. Secure all gland bushing nuts with pliers.

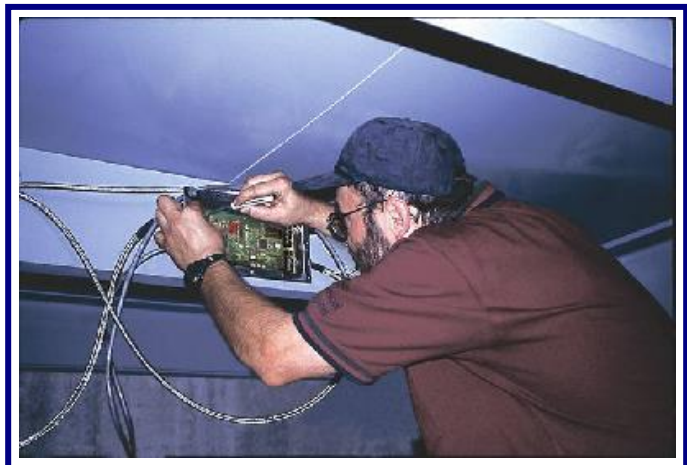

## 5.6. Instrument to Pit Power Supply Cable Connection

Use the appropriate manual for wiring the Smart Sectional Controllers (SSCs) and Pit Power Supplies (PPSs).

1. Bring the other end of the cable into the back of the instrument through the gland nut.

Press the end of the cable and connect the wires to TB1 near the back of the communications PC board.

Connect the **PPS** to an **SSC** (No. 1 or any SSC).

- Feed a cable from **SSC 1, TB3** through the bushing for in the **PPS** for **TB3**.

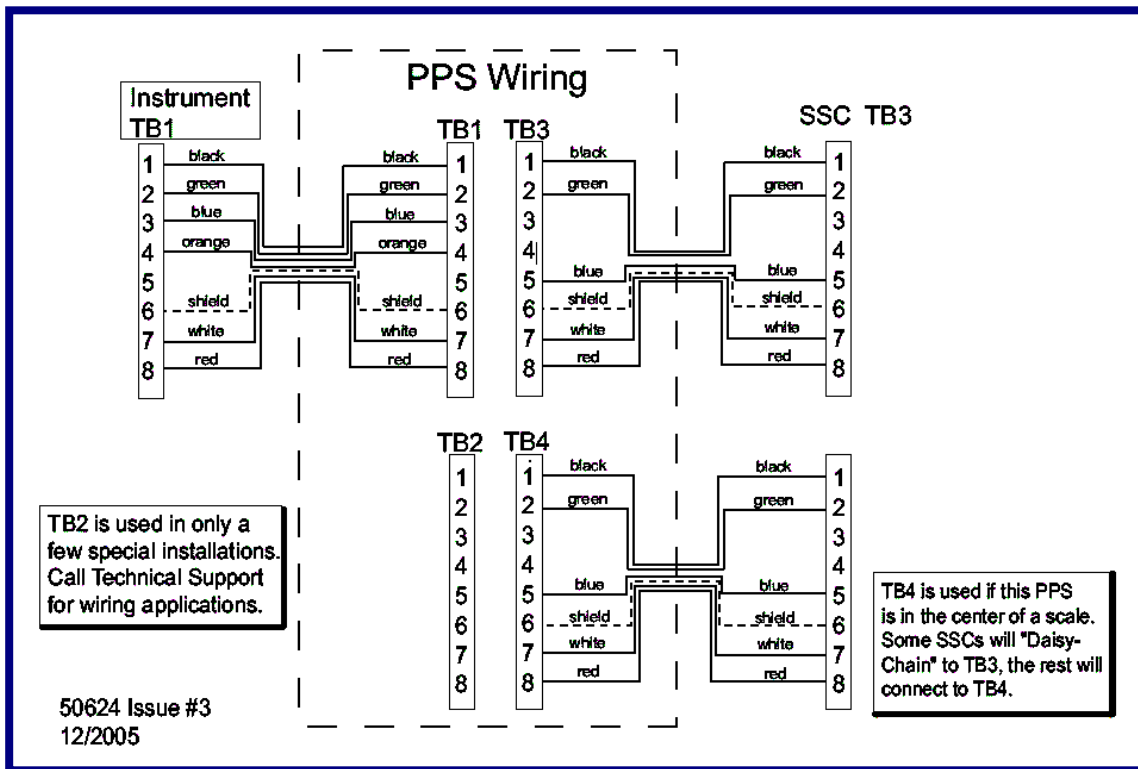

Instrument TB1 to Power Supply TB1	17246 Cable	Description
1	Black	28 VAC ( <b>AC</b> )
2	Green	AC Return ( <b>ACR</b> )
3	Blue	20 VDC ( <b>DC</b> )
4	Orange	Enable Transmit ( <b>EN</b> )
6	Shield	* Shield / DC Return
7	White	Transmit ( <b>TX</b> )
8	Red	Receive ( <b>RX</b> )



## 5.7. Grounding the Scale

- ✓ Intalogix™ Technology systems requires **two (2) ground rods** in the pit for proper connection.
- ✓ **Pit power supply** connects to one ground rod, and the **weighbridge** connects the other one.
- ✓ For accurate operation and protection against damage from lightning strikes, all of the components of the system must be properly grounded.
- ✓ Use the following guidelines to correctly ground the system:
- ✓ Use 8 AWG or larger wire, or braided ground straps.
- ✓ All ground connections should be two feet (2') or less, or as conditions warrant as short as possible.
- ✓ The SSCs and PPSs enclosures attach connections to the weighbridge. The weighbridge is then connected to a pit ground rod.
- ✓ The insulated **WHITE WIRE** from the PPS connects directly to the separate ground rod, **and not to the same rod as the weighbridge**.

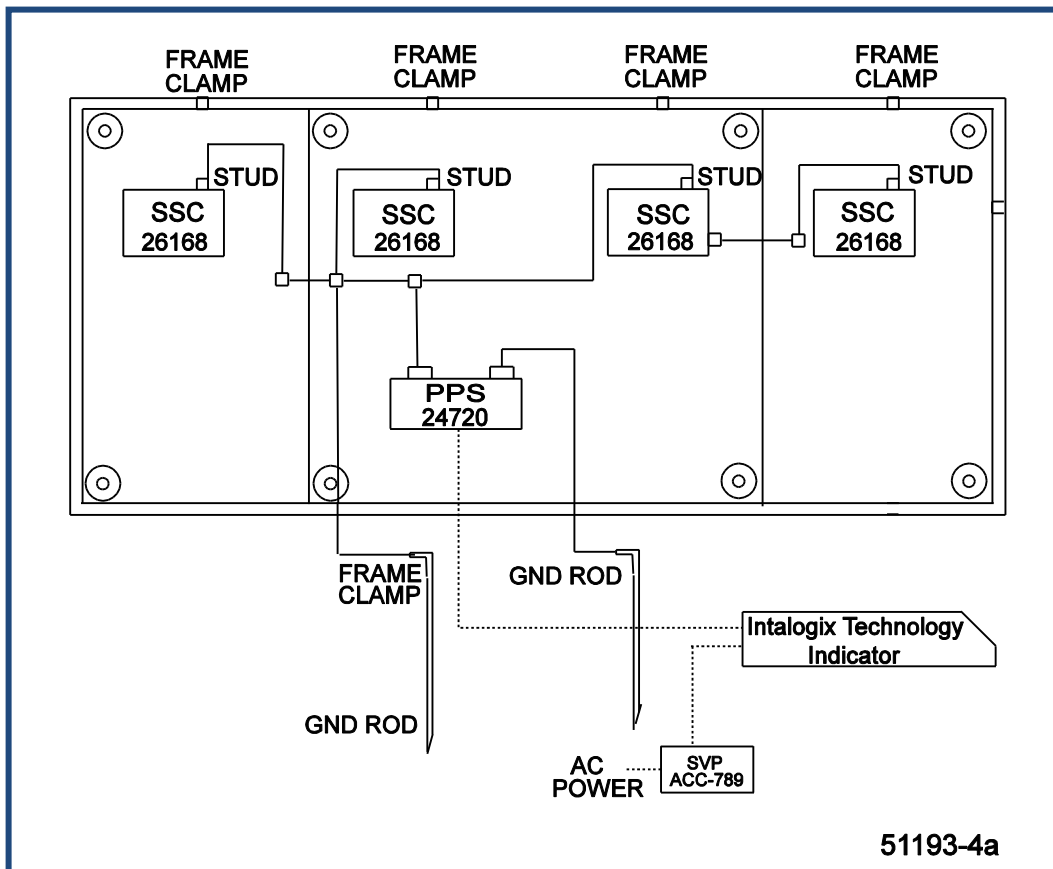

## 5.7. Grounding the Scale, Continued

The 117 VAC SVP Unit connects to a ground at the instrument's incoming power outlet.

- ✓ Use a voltmeter to test the electrical power source available.
- ✓ The Neutral-to-Ground voltage level must be 0.2 VAC or less.

# CAUTION

**Proper grounding is *REQUIRED***  
so the Surge Voltage Protection (SVP) adequately protects the scale!

## 5.8. Instrument and Accessories. Test and Calibration

Use the correct instrument manual(s) to calibrate and test the scale. Also use the correct accessory manual(s) for proper setup and testing of their functionality and operation.



---

## SECTION 6: SERVICE & MAINTENANCE

---

### 6.1. Recommended Preventive Maintenance Schedule

#### 6.1.1. Monthly

- ✓ Inspect the Scale and its understructure on a regular basis.
  - Check that all bolts are secure.
  - Check all clearances around the scale for any obstructions or interference with the free movement of the platform.
  - Check load cells for a level condition.
  - Check all check bolt clearances, both with and without a concentrated load over each section, one at a time.
  - Check concrete deck surface for any signs of damage or deterioration.

#### 6.1.2. Every six (6) months

- ✓ Inspect, clean and grease the load cell bearing cups.
  - Check cups and "O" rings for any damage
  - Inspect and adjust all Check Bolts, using anti-seize on the threads.
  - Ensure that the system is has proper ground connections
  - Remove power from the instrument.
  - Remove the box covers and inspect for water seepage.
  - Check gaskets for cracks and tears.
  - Check that all terminal screws and contacts are secure.
  - Check that all jumpers are in place.
  - Dress all wires, being certain they are completely off the ground.
  - Check that waterproof gland nuts are tight.
  - Reinstall the box cover, fasten the latches, and check the seal.
  - Check all clearances around the scale for any obstructions or interference with the free movement of the platform.
  - Check for build-up under platform and around load cells.
  - Check all bumper bolt clearances, both with and without a concentrated load over each section, one at a time..



## 6.2. Component Replacement Steps

### 6.2.1. *Rocker Column Load Cell Replacement*

1. **Remove power** from the system at the instrument.
2. **Lift the scale** using a proper sized and rated hydraulic jack under the closest to the "defective" cell location.
3. Remove the **defective load cell**.
4. Check and replace the upper and lower receiving cups if damaged.
5. Apply a small amount of **grease** on the top and bottom of the new load cell, then insert into the upper receiving cup.
6. Gently **lower the scale assembly**, ensuring proper placement of the load cell into the lower cup.
7. **Remove the SSC/Junction Box Enclosure Cover.**
8. **Loosen the gland bushing** to free the cable.
9. **Disconnect the defective load cell** from the SSC, noting the wire color code.
10. **Wire the new load cell** into the SSC/Junction Box.
11. Tighten all **gland nuts**.
12. Reinstall the cover, double-checking the seal as the clamps fasten to the box.
13. **Re-apply power** to the instrument.
14. **Test and adjust** the scale, and then **calibrate** it as necessary .

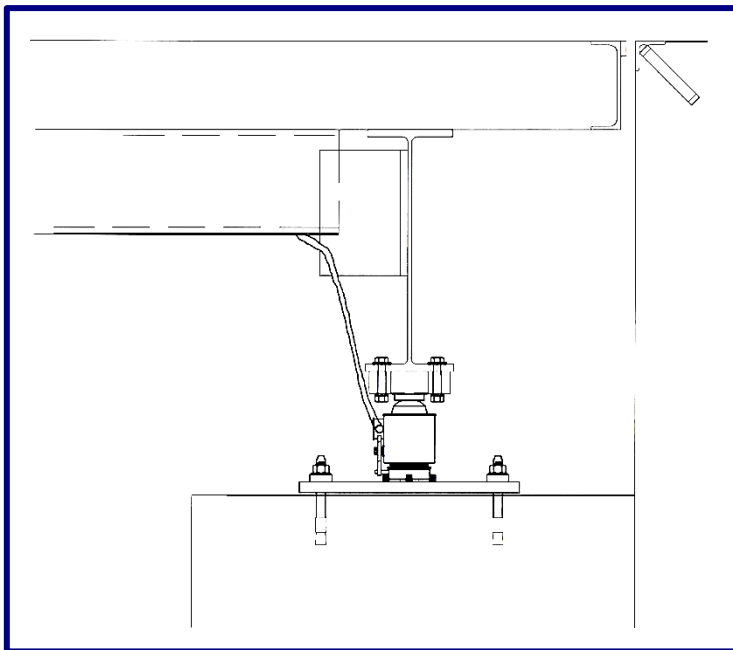

## 6.3. Component Replacement Steps, Continued

### 6.3.1. SSC Board Replacement

1. **Remove power** from the system at the instrument.
2. **Remove cover, disconnect all wiring**, noting colors and terminal locations.
3. **Remove screws** securing the PC board, then take it out carefully.
4. **Insert in new PC Board**, note dip switch settings.
5. **Set dip switches** for proper address on new PC board.
6. **Install** and secure with **all screws**.
7. **Connect all wires**.
8. **Secure cover**.
9. **Tighten all gland nuts**.

### 6.3.2. Pit Power Supply PC Board Replacement

1. **Remove power** from the system at the instrument.
2. **Remove cover**.
3. **Disconnect all wiring**.
4. **Remove screws** securing the power board.
5. **Remove PC Board**.
6. **Replace** with the new **PC Board**.
7. Install and **secure all screws**.
8. **Secure ground wire** to the new PC Board.
9. **Secure cover** with all screws.
10. **Tighten all gland nuts**.



# SECTION 7: PARTS

## 7.1. Load Cells and Hardware

PART NO.	DESCRIPTION
173115*	LOAD CELL, 66K RC 4-11/16", 1000 OHM, 2.4 MV/V
161197	UPPER & LOWER CUP (WITH ANTI-ROTATION PIN) KIT WITH GASKET
158283	LOAD CELL, PLT, 1 1/2" X 6" X 10" – 8-HOLE – UPPER LOADCELL PLATE
158282	LOAD CELL, PLT, 1 1/2" X 6" X 10" – 4-HOLE – UPPER LOADCELL PLATE
157069	LOCATING TOOL, 4-3/4"
157005	BASE PLATE, RC LOAD CELL, 3/4" X 6" X 15"
157278	3/8" X 1 1/4" SEL-LOK ROLL PIN– BASE PLATES, CUP RETENTION
61743	CLAMP BAR WASHER
161197	UPPER & LOWER CUP (WITH ANTI-ROTATION PIN) KIT WITH GASKET
161397**	HEIGHT SHIM, 1/16", LOWER CUP (2.75" OD)
161398**	HEIGHT SHIM, 1/8", UPPER CUP (2.25" OD)
<b>SIDE CHECKING PARTS</b>	
105592	BRACKET, SIDE CHECK "FB RED"
54225	5/8" FLAT WASHER
54363	5/8-11 HEX NUT
54563	5/8-11 X 6" MACH BOLT HEX HD
54304	1 1/8-7 HEX NUT
61391	1 1/8-7 X 9" FULL THD BOLT
<b>HIGHWAY SYSTEM LINK AND BALL CHECKING</b>	
88549	BALL TRANSFER
89171	BUMP PLATE 1" X 3 1/2" X 7 1/2"
88330	CHECK PLATE 1" X 3 1/2" X 7 1/2"
88810	DIRT SHIELD
84266	COTTER PIN 21-08 X .178
84100	CLEVIS PIN 1" X 4 1/4" SS
84267	ROD END (LINK) MALE
84268	ROD END (LINK) FEMALE

\* Included Upper and Lower Cups

\*\* See Image (below)

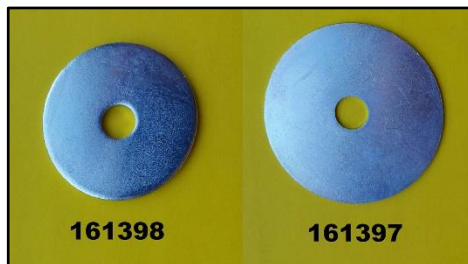

## 7.2. Spare Parts Lists

### 7.2.1. Recommended Spare Parts

Part No.	Qty	Description
175115	1	Load Cell, 411/16" RC, 50t (or 110k)
161197	1	Upper & Lower Cup (with anti-rotation pin) kit

### 7.2.2. Startup / Commissioning Spart Parts

Part No.	Qty	Description
175115	1	Load Cell, 411/16" RC, 50t (or 110k)

### 7.2.3. 2-Year Spare Parts List

Part No.	Qty	Description
175115	1	Load Cell, 411/16" RC, 50t (or 110k)
161197	1	Upper & Lower Cup (with anti-rotation pin) kit
79747	1	Rub Rail PVC End Caps
105297	1	Rub Rail Plugs

**Capital Spare Parts** – Not Applicable

# APPENDIX I: INTALOGIX™ WIRING

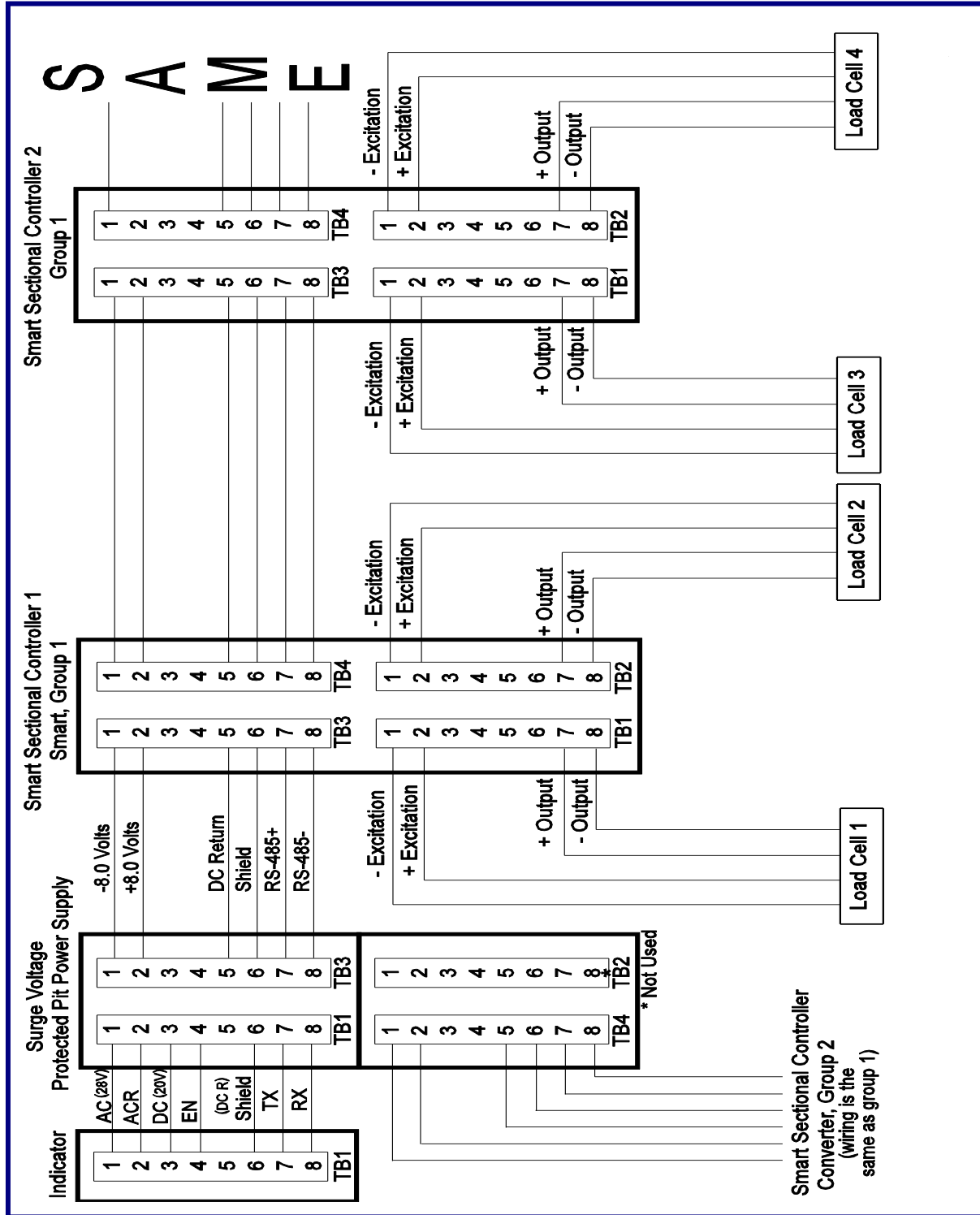



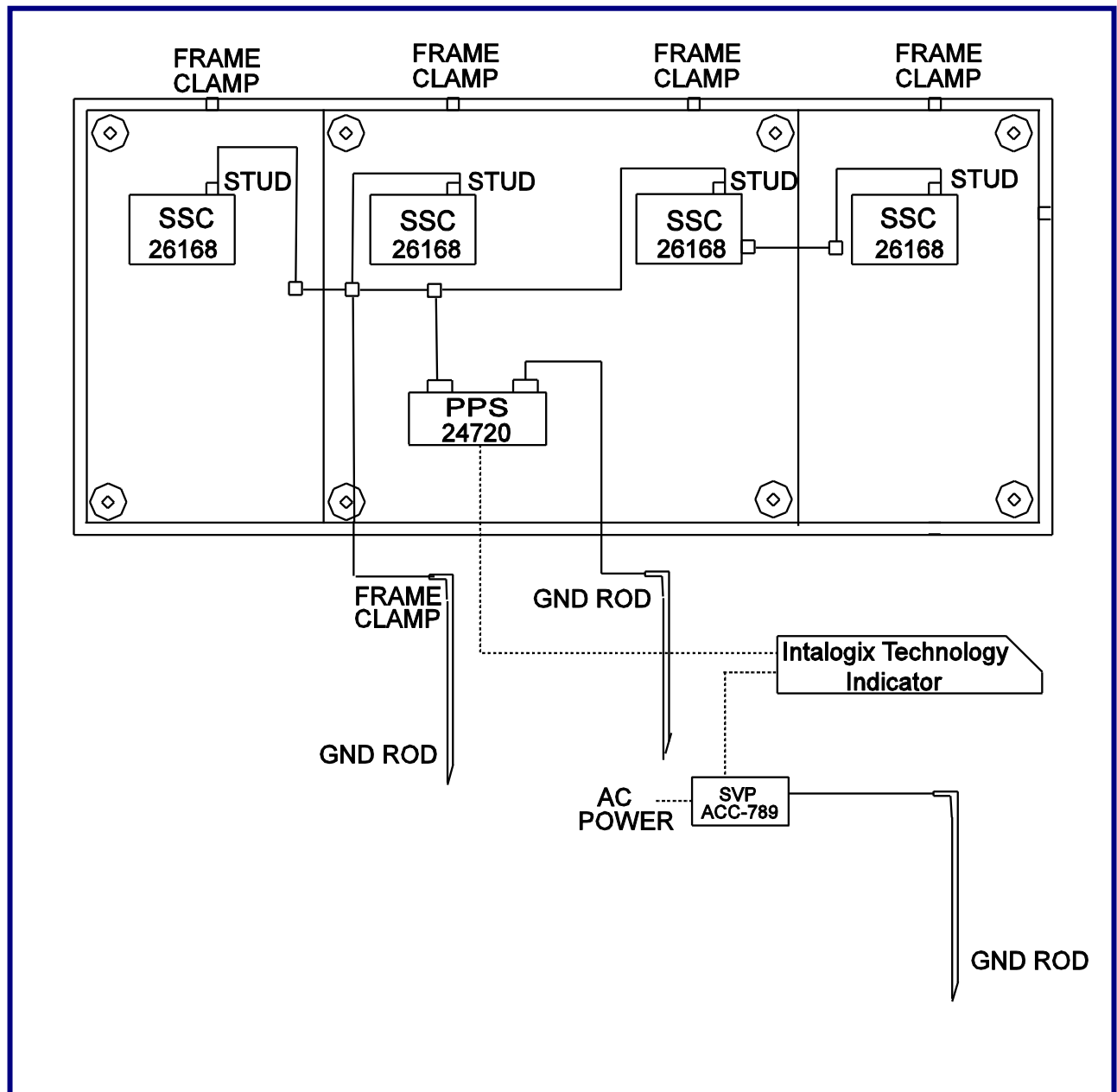

# APPENDIX II: FOUNDATION CHECK LIST



## Foundation Inspection

FOUNDATION FIELD CHECK LIST  
(Field Form)

A Foundation Inspection should ALWAYS be performed prior to scale installation and to confirm correct foundation construction. If possible this should be done prior to scale shipment.

- Tools required:
- Certified drawings and site plan
  - 100' and 25' steel tapes
  - Laser or builders level if possible
  - Straight edge for pit foundations (2 x 4, very straight and 4" wider than pit walls)
  - Construction paint (up-side-down type, for marking concrete).
  - 2' to 4' level
  - Hammer and concrete nails
  - String line (construction string)

Perform the following Foundation Checks. Refer to Methods and Procedures for complete description of each step. Recommended to copy check list and keep in job file. ALWAYS familiarize yourself with the CERTIFIED foundation prints for the job you are working on as model numbers and specifications are subject to change.

- 1. Site Plan and Certified Prints should be thoroughly reviewed to confirm accurate locations to the scale and all extra items (scoreboards, lights, poles, etc.) that are included in the bid or contract.
- 2. Check for truck and crane access, overhead wires, fences, green concrete, etc.
- 3. Dimensional length and width check; check all 4 sides and record on chart (other side).
- 4. Diagonal measurements check to verify that the foundation is square and record on chart (other side). These measurements should be equal, or within 1/2". Greater error could result in the scale not fitting in the foundation.
- 5. Check ALL pier heights to make sure they are the proper elevation and record on chart (other side). To high and the scale will not fit correctly, to low could result in excessive shimming..
- 6. In pit foundations check walls to verify they are straight. Straight walls are very important, but are even more critical for modular scales like the **Tundra Scale Series**.
- 7. Verify conduit locations and pull strings (if needed).
- 8. Verify ground rod locations.
- 9. Verify that drains and sump openings are piped correctly and are clear of debris.
- 10. Check the end coping to ensure they are centerline and that the coping is correct for the scale being installed (10', 11' or 12' width, etc). Check all coping, side and end, for hollow areas.
- 11. Verify location of any and all required embeds or pre-installed baseplates (i.e., Hwy System, RR scales, etc). All of these dimensions will be located on the Certified foundation prints.
- 12. Layout - To help in locating pre-installed baseplates, embeds, load-cell centerlines, etc., refer to Methods and Procedures section on Layout. See other side for foundation & Layout charts.

FF-2267

Issue #1

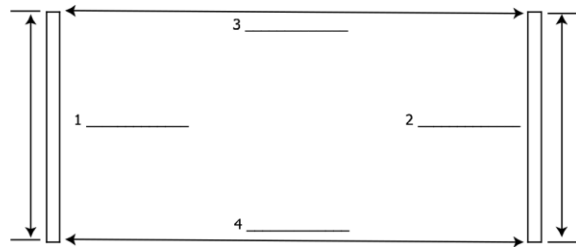

**Length & Width Check**

**Diagonal Measurements Check**

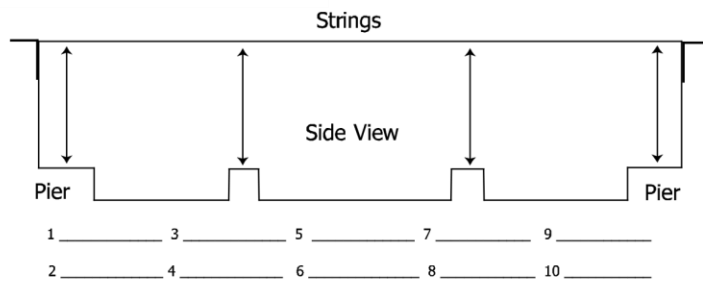
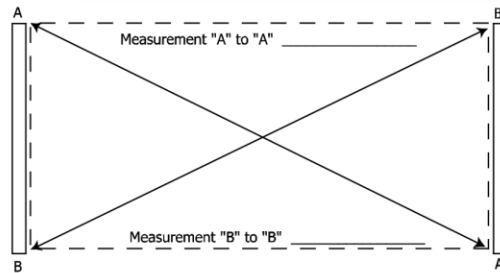

**Pier Height Check**

**Longitudinal Layout**

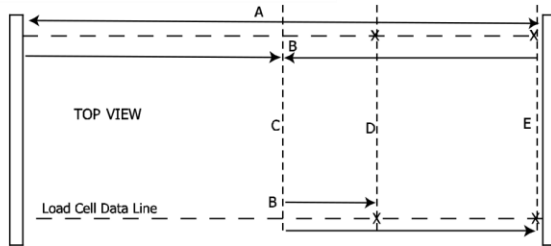
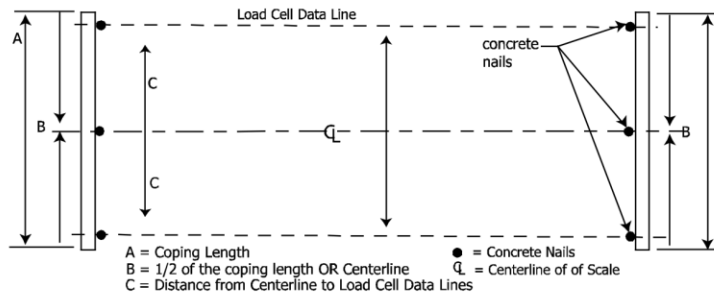

**Lateral Layout**

FF-2267

Issue #1

# APPENDIX III: PRECAST CONCRETE DECK SPECIFICATIONS

## A. Model Number 2600

		SCALE NO.	L Ft.	W Ft.	CLC Kilo-lbs.	CAP Tons	SEC
<b>XL 60K</b>	<b>10 ft.</b>	<b>166010</b>	10	10	60	45	2
		<b>166020</b>	20	10	60	45	2
		<b>166030</b>	30	10	60	45	2
		<b>166040</b>	40	10	60	75	3
		<b>166050</b>	50	10	60	75	3
		<b>166060</b>	60	10	60	100	4
		<b>166070</b>	70	10	60	100	4
		<b>166080</b>	80	10	60	100	4
		<b>166090</b>	90	10	60	100	5
		<b>166001</b>	100	10	60	100	5
		<b>166011</b>	110	10	60	100	6
	<b>166021</b>	120	10	60	100	6	
	<b>11 ft.</b>	<b>166110</b>	10	11	60	45	2
		<b>166120</b>	20	11	60	45	2
		<b>166130</b>	30	11	60	45	2
		<b>166140</b>	40	11	60	75	3
		<b>166150</b>	50	11	60	75	3
		<b>166160</b>	60	11	60	100	4
		<b>166170</b>	70	11	60	100	4
		<b>166180</b>	80	11	60	100	4
		<b>166190</b>	90	11	60	100	5
		<b>166101</b>	100	11	60	100	5
		<b>166111</b>	110	11	60	100	6
	<b>166121</b>	120	11	60	100	6	
	<b>12 ft.</b>	<b>166210</b>	10	12	60	45	2
		<b>166220</b>	20	12	60	45	2
		<b>166230</b>	30	12	60	45	2
		<b>166240</b>	40	12	60	75	3
		<b>166250</b>	50	12	60	75	3
		<b>166260</b>	60	12	60	100	4
		<b>166270</b>	70	12	60	100	4
		<b>166280</b>	80	12	60	100	4
		<b>166290</b>	90	12	60	100	5
<b>166201</b>		100	12	60	100	5	
<b>166211</b>		110	12	60	100	6	
<b>166221</b>	120	12	60	100	6		

## A. Model Number 2600, Continued

		SCALE NO.	L Ft.	W Ft.	CLC Kilo-lbs.	CAP Tons	SEC
<b>XLT 100K</b>	<b>10 ft.</b>	176010	10	10	100	60	2
		176020	20	10	100	60	2
		176030	30	10	100	100	3
		176040	40	10	100	100	3
		176050	50	10	100	135	4
		176060	60	10	100	135	4
		176070	70	10	100	135	5
		176080	80	10	100	135	5
		176090	90	10	100	135	6
		176001	100	10	100	135	6
		176011	110	10	100	135	6
	176021	120	10	100	135	7	
	<b>11 ft.</b>	176110	10	11	100	60	2
		176120	20	11	100	60	2
		176130	30	11	100	100	3
		176140	40	11	100	100	3
		176150	50	11	100	135	4
		176160	60	11	100	135	4
		176170	70	11	100	135	5
		176180	80	11	100	135	5
		176190	90	11	100	135	6
		176101	100	11	100	135	6
		176111	110	11	100	135	6
	176121	120	11	100	135	7	
	<b>12 ft.</b>	176210	10	12	100	60	2
		176220	20	12	100	60	2
		176230	30	12	100	100	3
		176240	40	12	100	100	3
		176250	50	12	100	135	4
		176260	60	12	100	135	4
		176270	70	12	100	135	5
		176280	80	12	100	135	5
		176290	90	12	100	135	6
176201		100	12	100	135	6	
176211		110	12	100	135	6	
176221	120	12	100	135	7		
<b>HWY</b>	176077	10,20,40	10	100	Per	7	
	176078	15,15,40	10	100	Per	7	
	176177	10,20,40	11	100	Per	7	
	176178	15,15,40	11	100	Per	7	
	176087	10,20,50	10	100	Per	7	



Manufactured by Fairbanks Scales, Inc.  
821 Locust Street  
Kansas City, MO 64106

[www.fairbanks.com](http://www.fairbanks.com)

---

# **Tundra Series**

## **Truck Scale**

### **Installation Manual – 51353**