

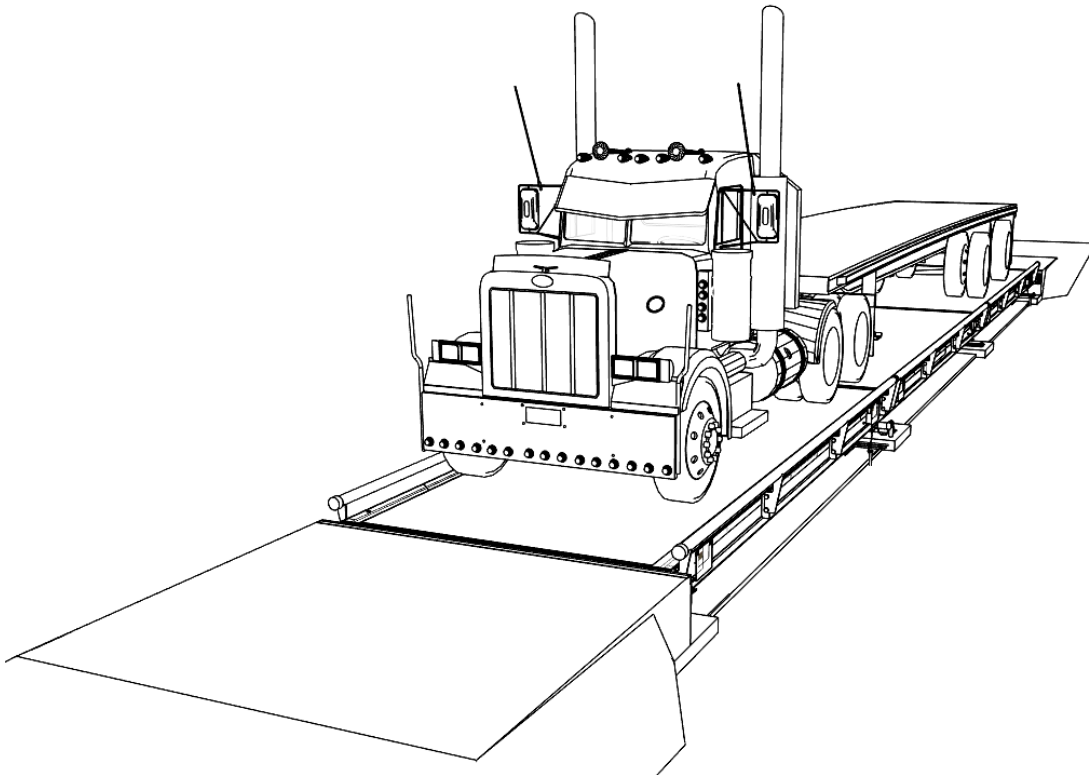

Installation Manual

Trident Precast Concrete Deck Truck Scale

TRIDENT 
Precast Concrete Truck Scale



Amendment Record

TRIDENT PRECAST CONCRETE DECK TRUCK SCALE Document 51354

Manufactured by Fairbanks Scales Inc.

| | | |
|------------|---------|--|
| Created | 11/2014 | |
| Revision 1 | 11/2014 | New Document Release |
| Revision 2 | 03/2015 | Updated Parts List |
| Revision 3 | 01/2016 | Updated Load Cell Parts |
| Revision 4 | 04/2116 | Updated Service and Maintenance > Scale Maintenance, Parts |
| Revision 5 | 02/2018 | Updated Part numbers |
| Revision 6 | 04/2118 | Updated Scale Installation, Added Spare parts section |
| Revision 7 | 04/2119 | Updated Cover Plate Model sections |
| Revision 8 | 10/2020 | Updated Electrical Installation > Wiring – 21912 Analog Junction Box |
| Revision 9 | 04/2021 | Updated: Required Tools |

Disclaimer

Every effort has been made to provide complete and accurate information in this manual. However, although this manual may include a specifically identified warranty notice for the product, Fairbanks Scales makes no representations or warranties with respect to the contents of this manual, and reserves the right to make changes to this manual without notice when and as improvements are made.

Fairbanks Scales shall not be liable for any loss, damage, cost of repairs, incidental or consequential damages of any kind, whether or not based on express or implied warranty, contract, negligence, or strict liability arising in connection with the design, development, installation, or use of the scale.

© Copyright 2021

This document contains proprietary information protected by copyright. All rights are reserved; no part of this manual may be reproduced, copied, translated, or transmitted in any form or by any means without prior written permission of the manufacturer.

TABLE OF CONTENTS

| | |
|---|-----------|
| SECTION 1: GENERAL INFORMATION | 6 |
| 1.1. Introduction..... | 6 |
| 1.1.1. <i>Description</i> | <i>6</i> |
| 1.1.2. <i>Certifications</i> | <i>7</i> |
| 1.1.3. <i>Load Cell Technical Specifications</i> | <i>7</i> |
| 1.1.4. <i>Platform Specifications</i> | <i>7</i> |
| 1.2. General Service Policy | 8 |
| 1.3. Overview..... | 9 |
| 1.3.1. <i>Physical Installation Notes.....</i> | <i>9</i> |
| 1.3.2. <i>Conferring with Our Client.....</i> | <i>9</i> |
| 1.3.3. <i>Pre-Installation Checklist.....</i> | <i>10</i> |
| 1.3.4. <i>Unpacking</i> | <i>10</i> |
| 1.3.5. <i>Equipment Checkout.....</i> | <i>11</i> |
| 1.3.6. <i>Users' Responsibility.....</i> | <i>11</i> |
| SECTION 2: SCALE INSTALLATION..... | 12 |
| 2.1. Introduction..... | 12 |
| 2.2. Required Tools, Equipment and Materials..... | 12 |
| 2.3. Foundation | 13 |
| 2.4. Undermount Model | 14 |
| 2.4.1. <i>Preparing the Modules for Lifting (Undermount Model)</i> | <i>15</i> |
| 2.4.2. <i>Setting the Center Module (Undermount Model)</i> | <i>15</i> |
| 2.4.3. <i>Setting the End Modules (Undermount Model)</i> | <i>16</i> |
| 2.4.4. <i>Connecting the Modules (Undermount Model)</i> | <i>17</i> |
| 2.4.5. <i>Checking Adjustments (Undermount Model)</i> | <i>18</i> |
| 2.5. Cover Plate Model..... | 19 |
| 2.5.1. <i>Preparing the Modules for Lifting (Cover Plate Model)</i> | <i>19</i> |
| 2.5.2. <i>Setting the Center Module (Cover Plate Model)</i> | <i>21</i> |
| 2.5.3. <i>Setting the End Modules (Cover Plate Model)</i> | <i>22</i> |
| 2.5.4. <i>Connecting the Modules (Cover Plate Model)</i> | <i>23</i> |
| 2.5.5. <i>Checking Adjustments (Cover Plate Model).....</i> | <i>23</i> |
| 2.6. Installing Load Cells | 26 |
| 2.6.1. <i>Load Cell Cables.....</i> | <i>26</i> |
| 2.6.2. <i>Cable Hangers</i> | <i>27</i> |
| 2.6.3. <i>Complete Installation.....</i> | <i>27</i> |
| 2.6.4. <i>Installing Load Cells – Undermount Model Diagram.....</i> | <i>27</i> |
| 2.6.1. <i>Installing Load Cells - Cover Plate Model Diagram.....</i> | <i>28</i> |
| 2.7. Analog Balance Box (21912) Installation..... | 28 |
| 2.7.1. <i>Boxes.....</i> | <i>28</i> |
| 2.7.2. <i>Wiring.....</i> | <i>29</i> |
| SECTION 3: ELECTRICAL INSTALLATION | 30 |
| 3.1. Load Cell Wiring Color Codes..... | 30 |
| 3.2. Wiring – 21912 Analog Junction Box | 30 |
| 3.3. Wiring Guide | 31 |
| 3.3.1. <i>Instrument cable connection, balance box.....</i> | <i>31</i> |
| 3.3.2. <i>Adjusting Cells/Sections.....</i> | <i>32</i> |



- 3.4. Wiring SSCs and PPSs for Intalogix systems..... 32**
 - 3.4.1. *Intalogix Load Cell Numbering 33*
 - 3.4.2. *Grounding SSCs 34*
 - 3.4.3. *Instrument-to-PPS Cable Connection..... 34*
 - 3.4.4. *Wiring – Intalogix Junction Box..... 34*
- SECTION 4: SERVICE & MAINTENANCE 35**
 - 4.1. Scale Maintenance..... 35**
 - 4.2. Mechanical Faults 35**
 - 4.3. Replacing a RC Load Cell..... 36**
 - 4.3.1. *Load Cell Specifications 36*
- SECTION 5: PARTS..... 37**
 - 5.1. Platform Parts List 37**
 - 5.2. Load Cell Parts..... 38**
 - 5.3. Rub Rails 38**
 - 5.4. Spare Parts..... 39**
 - 5.4.1. *Recommended Spare Parts 39*
 - 5.4.2. *Startup / Commissioning Spart Parts..... 39*
 - 5.4.3. *2-Year Spare Parts List..... 39*
- APPENDIX I: FOUNDATION CHECKLIST 40**
- APPENDIX II: PRECAST CONCRETE DECK SPECIFICATIONS 42**
 - A. Model Number 6030-PC-UM (CP) 42
- APPENDIX III: WIRING DIAGRAMS..... 43**
 - A. Trident Precast Concrete Deck Typical Installation Wiring Diagram – Analog..... 43
 - B. Trident Precast Concrete Deck Typical Installation Wiring Diagram - Intalogix... 43

SECTION 1: GENERAL INFORMATION

1.1. Introduction

This manual provides installation instructions for the Fairbanks Trident Precast Concrete Deck Truck Scale.

- The concrete foundation work must be performed according to the certified prints issued for the specific customer and order number.
- The name and order number for the customer will be on the prints.

IMPORTANT NOTE: *It is the owner's responsibility to document, notify, and follow-up regarding shipping damage with the carrier.*

1.1.1. Description

The factory-poured truck scales are available in various lengths and widths.

- The scale is made up of modules of 10', 15', 20' or 23'4" in length.
- All modules are assembled and welded at the factory.
- The concrete deck is mixed, poured, placed, finished, and cured at the factory.
- The scale should be located so that vehicles can approach and exit the scale as easily as possible.
- The platform should be visible from the instrument location.
- Drainage of surface water must be such that water does not collect under the scale.
- Smooth and level approaches are required at each end of the platform to reduce loading shock and facilitate testing of the scale.
- Approaches must conform to the requirements of the law in the state in which the scale is being installed.
- In the absence of such laws the approaches must conform to **Paragraph UR.2.6 National Institute of Standards and Technology Handbook 44**, which states that the **first ten feet (10')** must be level and on the same plane as the scale platform.
- See [Appendix II](#) For specifications and sizes.



1.1.2. Certifications

NTEP CC: 96-089A3

MC: AM - 4949

1.1.3. Load Cell Technical Specifications

| | |
|-----------------------|--|
| Capacity | 66,000 lbs. |
| Type | 4 1 ¹ / ₁₆ " Stainless Steel Rocker Column (RC Cells) |
| Sealing | Glass-to-Metal Connection Points, complete hermetic sealing; cable entry sealed by four (4) water-tight gland bushings |
| Material | Stainless Steel |
| Rating | NEMA 6P (IP68 / 69K) |
| Resistance | 1,000 Ohms |
| Operating Temperature | -10 to +40 °C (-14 to 104 °F) |
| Output | 2.4 mv/v |
| Combined Error | ≤0.02% |
| Zero Balance (FSO) | 1.0% |
| Excitation | 5 to 15 VDC |
| Ultimate Overload | 300% |
| Cable Length | 15' |
| Cable Protection | Stainless Steel Sheathing |
| Approvals | NTEP CC# 14-024 Factory Mutual (FM) Approved |

1.1.4. Platform Specifications

| | |
|---------------------|---|
| Deck Dimensions | Widths: 10' and 11' Standard Lengths: 10' to 120' Standard |
| Scale Capacity | 50 tons to 125 tons |
| CLC | 80,000 lbs |
| Sections | 2 thru 7 |
| Deck Construction | Precast Concrete |
| Module Construction | Structural Steel |
| Deck Thickness | 4" |
| Approval | NTEP CC# 96-089 MC# AM-4949 |

1.2. General Service Policy

Prior to installation, ***always*** verify that the equipment satisfies the customer's requirements as supplied, and as described in this manual.



If the equipment cannot satisfy the application and the application cannot be modified to meet the design parameters of the equipment, **the installation should NOT be attempted.**

It is **the customer/operator's responsibility** to ensure the equipment provided by Fairbanks is operated within the parameters of the equipment's specifications and protected from accidental or malicious damage.

W A R N I N G

Absolutely **NO physical, electrical, or program modifications** (other than selection of standard options and accessories) may be made to this equipment by customers.

Repairs must be performed by Fairbanks Scales service technicians and authorized distributor personnel **ONLY!**

Failure to comply with this policy voids all implied and/or written warranties.

1.3. Overview

1.3.1. Physical Installation Notes

- Check all devices for proper operation. If any error messages occur, refer to Troubleshooting or the proper manual of that device.
- ***Only those charges which are incurred as a result of the equipment's inability to be adjusted to performance specifications may be charged to warranty.***
- No physical alterations (mounting holes, etc.) are allowed during installation.

The installing technician is responsible that all personnel are fully trained and familiar with the equipment's capabilities and limitations before the installation is considered complete.

- All electrical assemblies must be replaced as assemblies or units.
 - Replacement of individual components is not allowed.
 - These components must be returned intact for replacement credit per normal procedures.
- All electronic and mechanical adjustments are considered to be part of the installation and are included in the installation charge(s).
 - Included is any required computer programming or upgrades.
 - Included are any accuracy and/or operational specification changes.
- The AC receptacle/outlet shall be located near the Instrument and easily accessible.
- Electrical connections other than those specified may not be performed.

1.3.2. Conferring with Our Client

- The technician must be prepared to recommend the arrangement of components which provide the most efficient layout, utilizing the equipment to the best possible advantage.
- The warranty policy must be explained and reviewed with the customer.

1.3.3. Pre-Installation Checklist

The following points should be checked and discussed with the **Area Sales Manager and/or customer**, if necessary, before the technician goes to the site and installs the equipment.

- ✓ Check the customer's application to make certain it is within the capabilities and design parameters of the equipment.
- ✓ If the installation process might disrupt normal business operations, tell the customer and ask that they make adequate arrangements.
- ✓ Be sure that the equipment operator(s) are available for training.
- ✓ The service technician reviews the recommended setup with the Area Sales Manager or Area Service Manager, and together they identify all necessary variations to satisfy the customer's particular application.



1.3.4. Unpacking

Follow these guidelines when unpacking all equipment:

- ✓ Check in all components and accessories according to the customer's order.
- ✓ Remove all components from their packing material, checking against the invoice that they are accounted for and not damaged.
 - *Advise the shipper immediately, if damage has occurred.*
 - *Order any parts necessary to replace those which have been damaged.*
 - *Keep the shipping container and packing material for future use.*
 - *Check the packing list.*
- ✓ Collect all necessary installation manuals for the equipment and accessories.
- ✓ Open the equipment and perform an inspection, making certain that all hardware, electrical connections and printed circuit assemblies are secure.
- ✓ Do not reinstall the cover if the final installation is to be performed after the pre-installation checkout.



1.3.5. Equipment Checkout

Position the equipment with these points in mind:

- ✓ Intense direct sunlight can harm the display.
- ✓ Do not locate near magnetic material or equipment/Instruments which use magnets in their design.
- ✓ Avoid areas which have extreme variations in room temperatures. Temperatures outside the Instrument's specifications will affect the weighing accuracy of this product.
- ✓ Do not load the platform if there is any evidence of damage to the platform or supporting structure.



1.3.6. Users' Responsibility

- ✓ All electronic and mechanical calibrations and/or adjustments required for making this equipment perform to accuracy and operational specifications are considered to be part of the installation.
- ✓ They are included in the installation charge.
 - *Only those charges which are incurred as a result of the equipment's inability to be adjusted or calibrated to performance specifications may be charged to warranty.*
- ✓ Absolutely no physical, electrical, or program modifications other than selection of standard options and accessories are to be made to this equipment.
- ✓ The equipment consists of printed circuit assemblies which must be handled using ESD handling procedures, and must be replaced as units.
 - *Replacement of individual components is not allowed.*
 - *The assemblies must be properly packaged in ESD protective material and returned intact for replacement credit per normal procedures.*



SECTION 2: SCALE INSTALLATION

2.1. Introduction

Installation consists of these elements.

- A. Foundation check, layout, and base plate setting.**
- B. Tools, materials, documentation, and a crane.**
- C. Setting the modules.**
- D. Setting the modules on load cells.**

2.2. Required Tools, Equipment and Materials

- Certified Prints.
- A mobile crane of sufficient capacity to safely lift and place the weigh bridge modules.
 - Approximate maximum weights:
Factory poured modules – 14,500 lbs., 7.2 tons, ±5% for 23' x 10' module without rub rails.
- Four (4) equal length (20 ft) lifting chains or cables with hooks to safely attach to the modules at the lifting points.

NOTE: Always reserve the lifting chains or cables in advance from the crane vendor.

- Machinist's levels (Starrett 134 and 132-6)
- Hand tools
 - Wrenches and Sockets:
 - 15/16" ▪ 1 1/8" ▪ 3/4" Hex Wrench
 - 1 1/2" ▪ 1 11/16"
- Hammer drill with 5/8" bit, 24"
- Hydraulic jacks -- Use hydraulic jacks that have sufficient capacity plus (+) a safety factor for the model of scale you are installing.
 - **96496** 30 ton jack
 - **96497** Hand pump
 - **96498** 6' hose

- 100' steel tape measure
- String line and / or chalk line
- Pry bars
- Grease and anti-seize (*see note below*)

NOTE: Grease for load cell cups: equal to *Super Lube White Grease* (food grade)

- Load cell locating tools, one for each load cell,
 - Part No. **157069**.

2.3. Foundation

Before installing any part of the scale, the foundation must be checked for accuracy using Foundation Inspection, Field Check List, FF-2267 / 101732 (see Appendix I).

1. Layout and position the base plates in the proper locations using the Methods & Procedures and Certified prints.
 - a. Each base plate must be level and in full contact with the top of the pier.
 - b. Adjustments are made by chipping the concrete or grouting under the base plates.
2. Re-check the locations of each base plate against the certified prints.
3. Insert four (4) $\frac{3}{8}$ " roll pins into each Base Plate.
4. Put a $\frac{3}{16}$ " shim under the lower cups and insert them into the base plates.
5. The lower cups for load cells have a pin which should be aligned towards the center line of the scale.
6. Place the upper cup on the edge of the upper foundation next to each base plate.
7. Place the load cell locating tool next to each base plate.

2.4. Undermount Model

The Undermount Model image displays below.

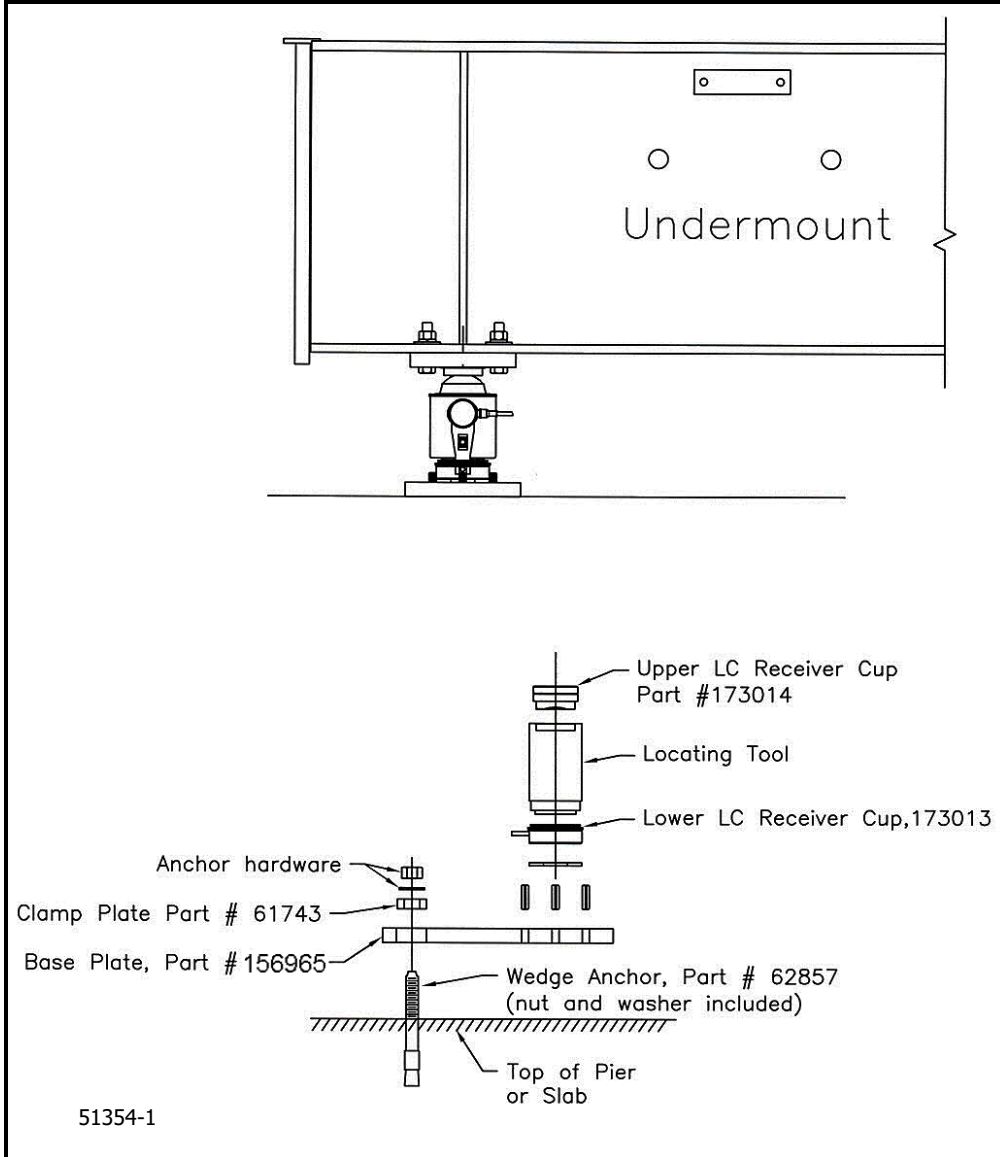

2.4.1. Preparing the Modules for Lifting (Undermount Model)

- The modules do not have integrated lifting channels.
- One (1) set of lifting eye bolts (threaded eye bolts) is provided by Fairbanks.
- Thread and bolt lifting eye bolts at each corner of the module for proper lifting.

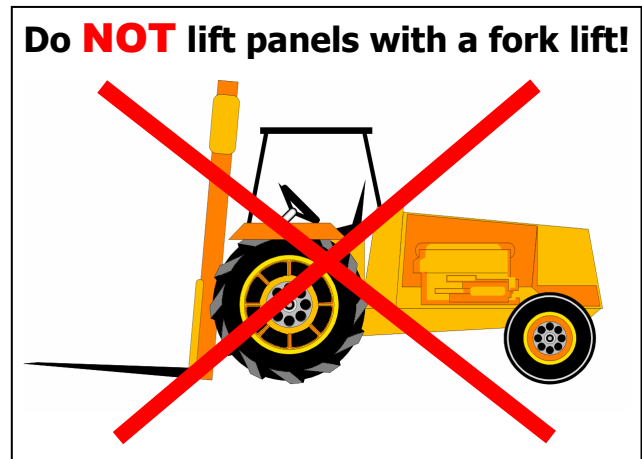
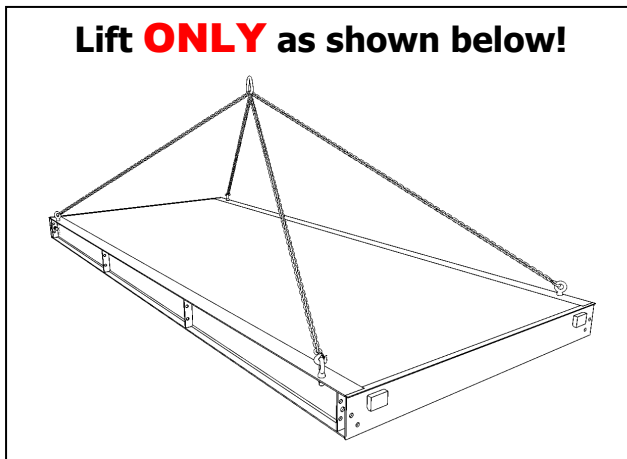
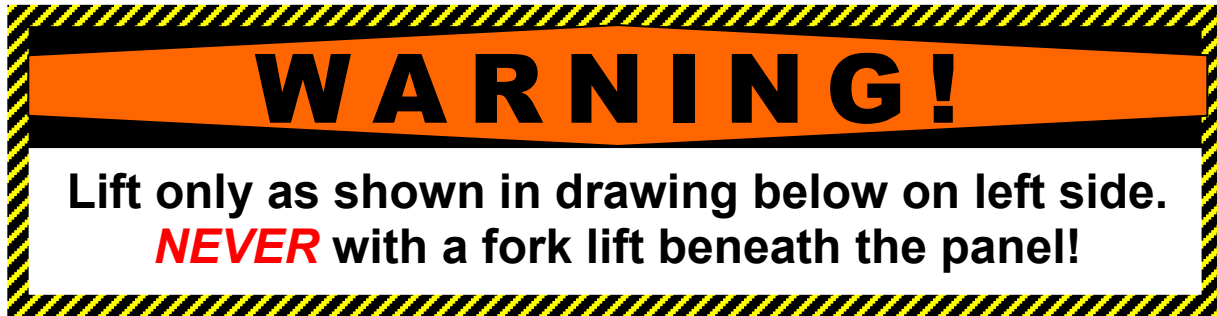

2.4.2. Setting the Center Module (Undermount Model)

✓ **Always set the Center Module first.**

- The **Center Module** has four (4) load cells to install. All other modules have two load cells.
- Place these modules in the proper order and align in the foundation so that all modules fit correctly.

To set the Center Module:

1. Place blocks that will set the modules at a height slightly less than the finished height as the safety blocks, or for setting the modules on.
2. Lift the center module to a location above the four center load cell base plates.
3. Install a load cell bearing cup into the upper receiver of each corner, grease will help hold the cup in place.
4. Insert the upper end of the locating tool over the upper cup on the module.

5. Set the module directly on the locating tools and the blocks will act as safety stands.
6. Lower the module while holding the locating tool upright and guiding the bottom of the tool into the lower cup.
7. When the center module is set on all four locating tools, keep tension on the cables until the module is centered and straight. Once square and plumb are verified, you can release tension *slowly*.
8. Use hydraulic jacks to lift the unit slightly and shift the base plates to get the locating tools plumb.
9. Measure from each side of each end of the module, to the end walls, to be certain the module is plumb and square before removing tension.
10. Remove threaded eye bolts and install on next module for proper lifting.

2.4.3. Setting the End Modules (Undermount Model)

1. Guide the modules into place with the supporting blocks on the end of the module coming to rest on the supporting blocks of the center module. Lower the other end of the module onto the load cell locating tools or blocks.
2. Before releasing tension on the cables, check the alignment of the end modules to the center module and to the end wall.
3. Use the provided shims to set height and fill any gaps on the supporting blocks to get the modules aligned.
4. Repeat this process for the other end module or for the interior module.

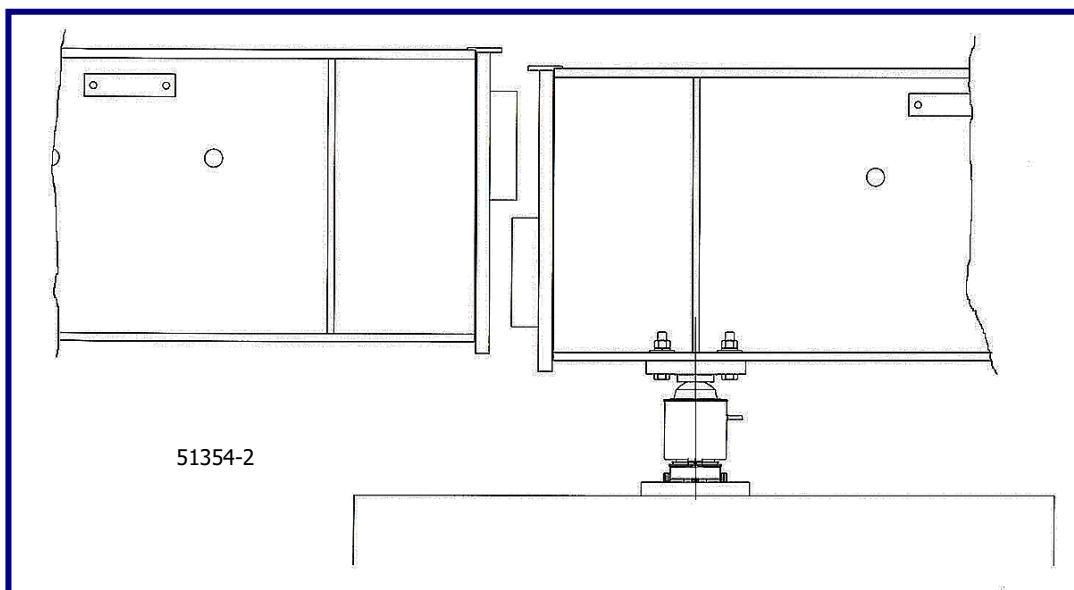

Undermount model Panel Block

2.4.4. Connecting the Modules (Undermount Model)

1. Bolt the modules together using the 1-1/8" x 7" full-thread rod, lock washer, flat washers and nut provided.
2. Remember to shim the supporting blocks if necessary to align modules.
3. Snug nuts, but do not fully tighten them yet.

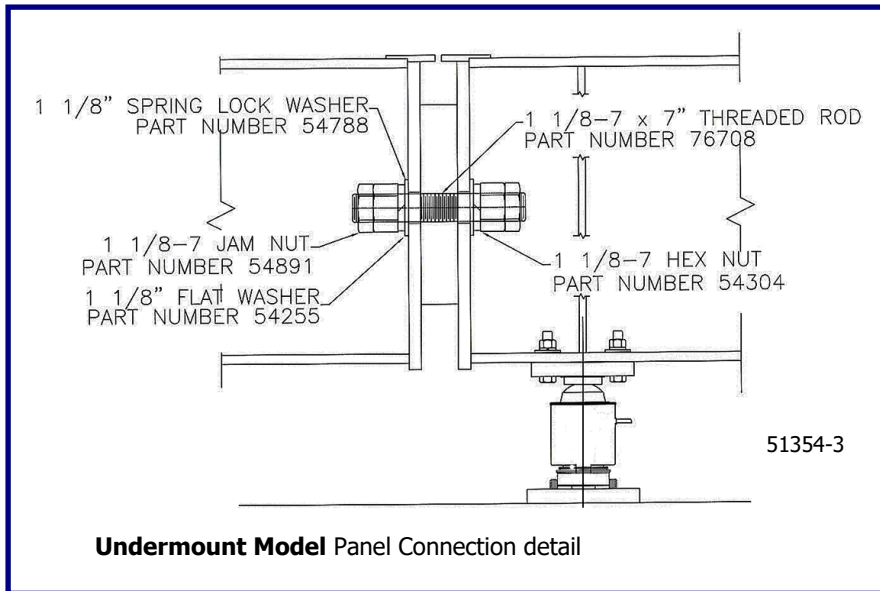

WARNING!

Module-to module bolts ***MUST*** be installed correctly and with proper torque after all lifting, etc., is completed. ***Do NOT*** substitute or omit bolts.

2.4.5. Checking Adjustments (Undermount Model)

1. **Adjust end checking** -- Adjust the end checking bolts so that they touch and prevent movement. (See figure 51354-7).
2. **Install the side checking brackets** -- Bolt the brackets to the end checking plates embedded in the end walls per certified prints.
 - *These bolts should touch the block they bump against.* (See figure 51354-8).

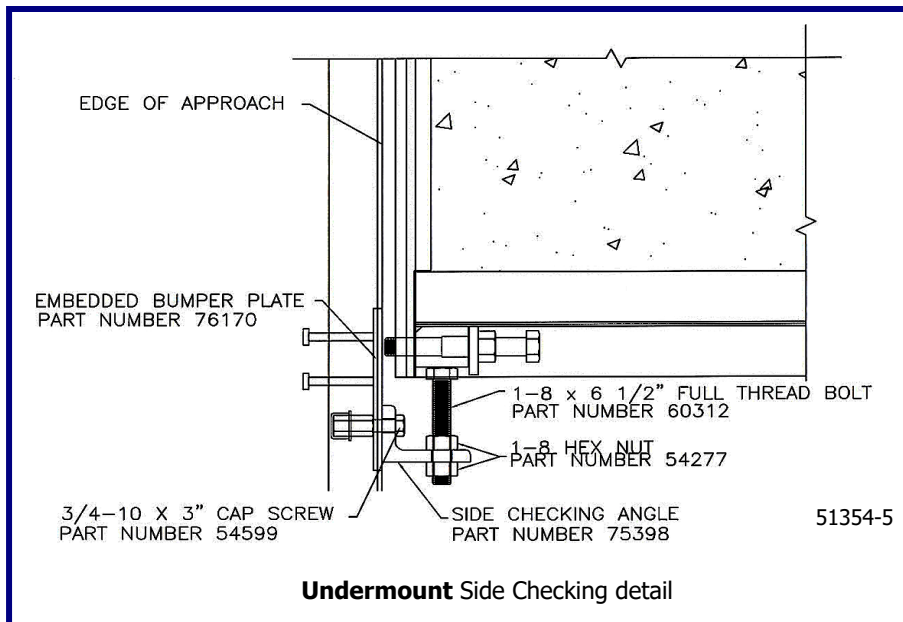
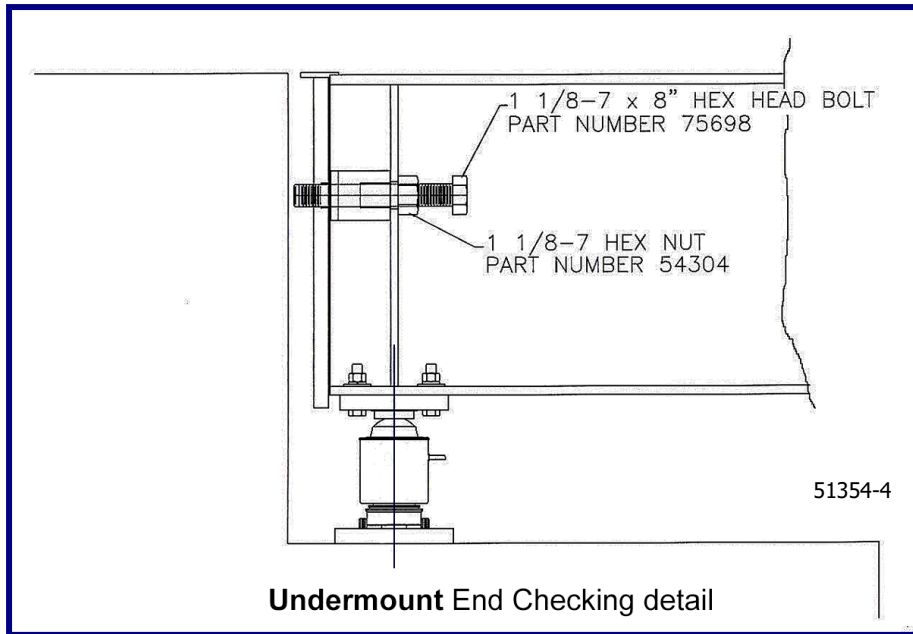

2.5. Cover Plate Model

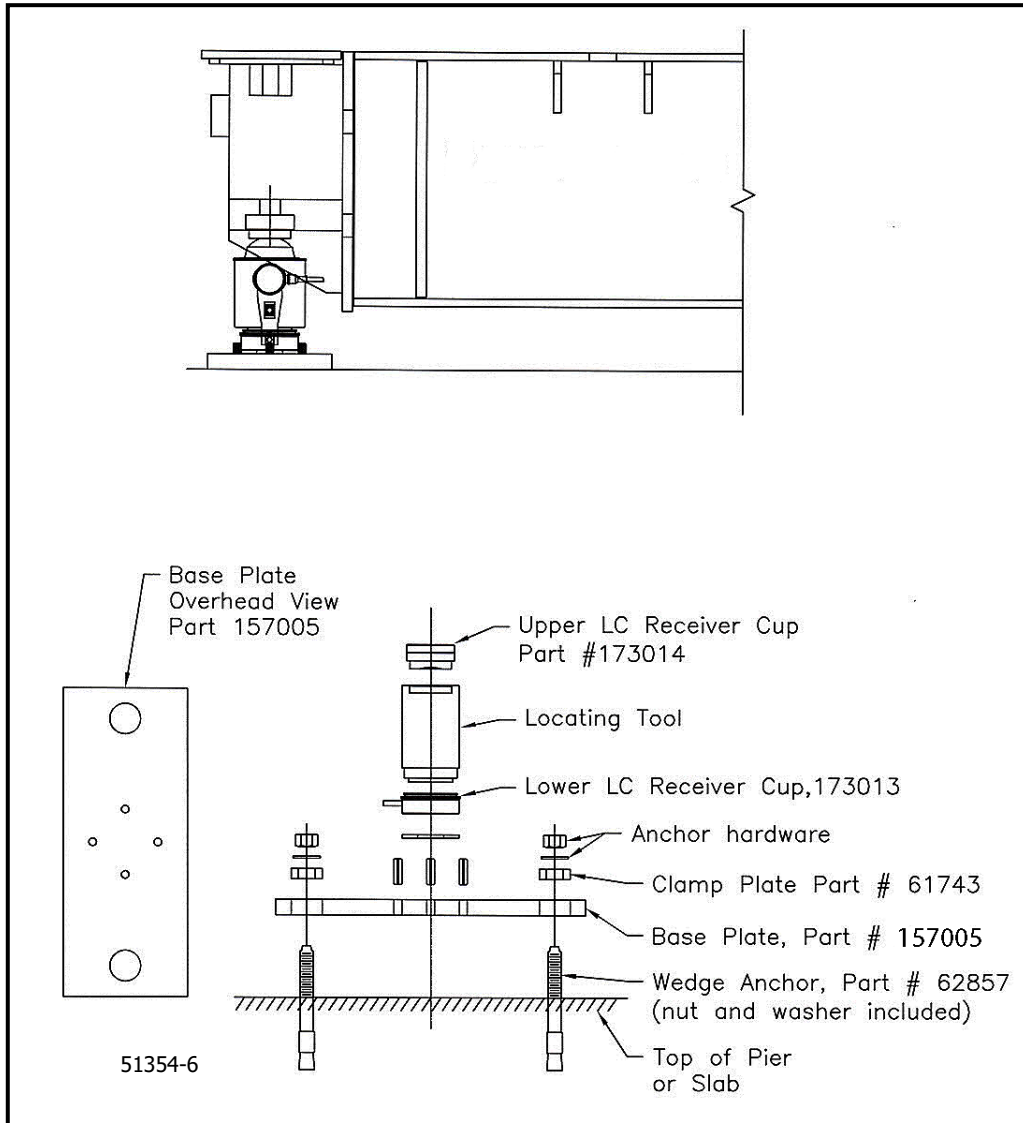

2.5.1. Preparing the Modules for Lifting (Cover Plate Model)

1. Install interlocking pin into hole on top of the load block of the panel already resting on locating tools.
2. Guide the modules into place with the deck seats on the end of the module coming to rest on the center module load block interlocking pins. Lower the other end of the module onto the load cell locating tools or blocks.
3. Before releasing tension on the cables, check the alignment of the end modules to the center module and to the end wall.

2.5.1. Preparing the modules for lifting, Continued

The Pit style modules must have lifting brackets installed at each corner before they can be lifted. Use only the high-strength bolts provided or parts from the factory. Tighten the bolts as tight as possible.

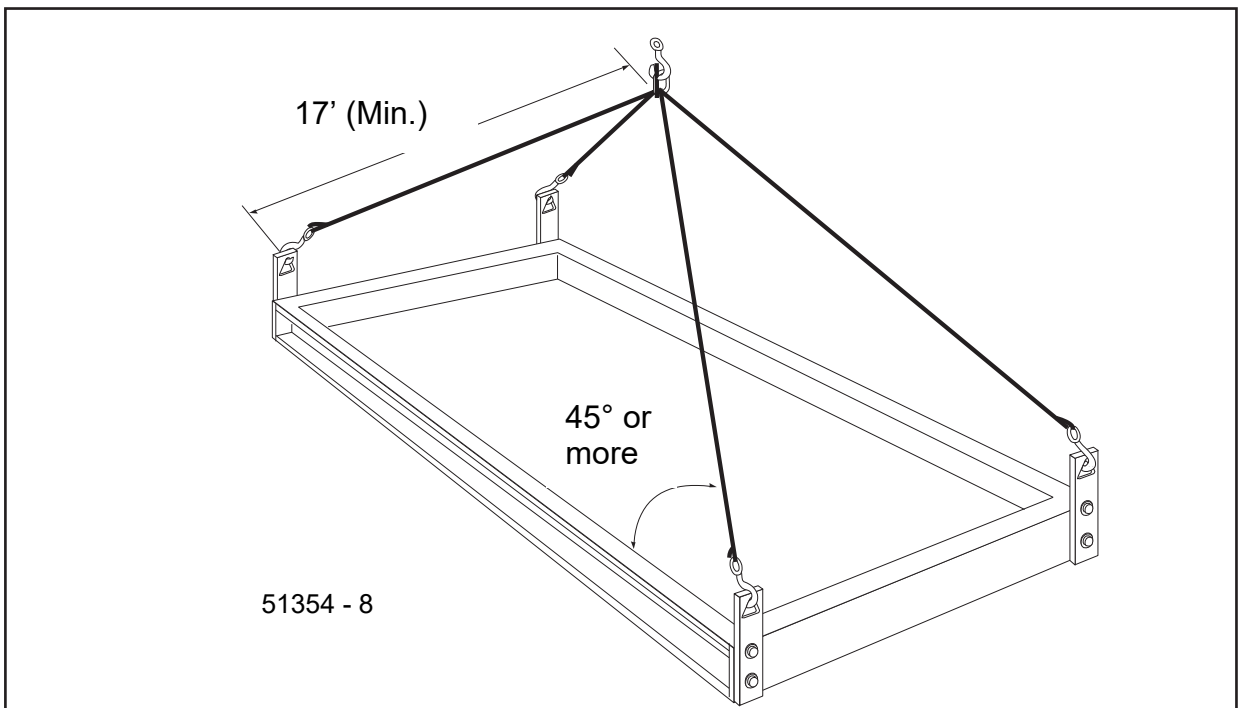
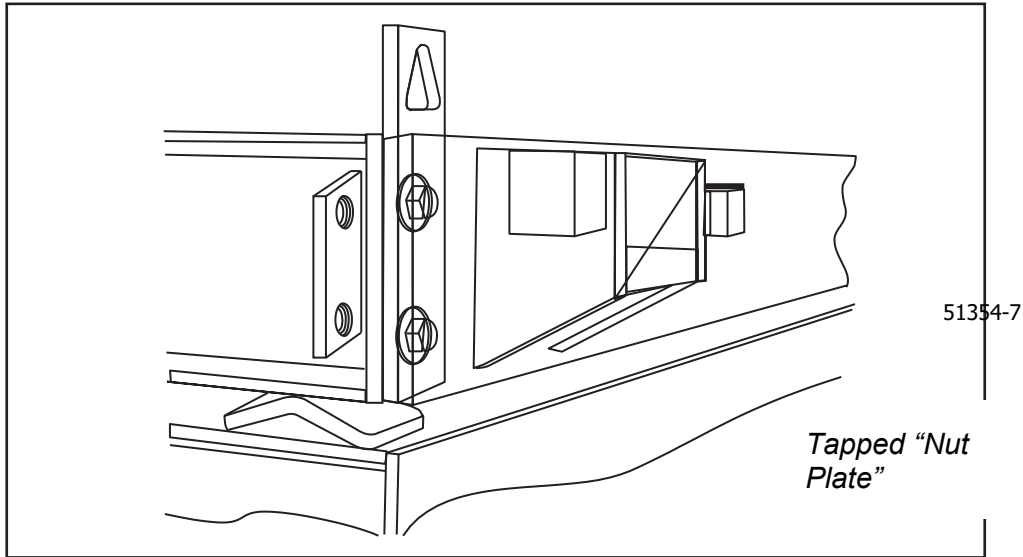

2.5.2. Setting the Center Module (Cover Plate Model)

The center module is always set first. The center module will have four load cells to install; all other modules will have two load cells. The modules must be placed in the proper order and aligned in the foundation so that all modules fit correctly.

These scales do NOT have a left-right orientation and have 'unmarked' ends. The center module may be installed facing either direction as long as it is in the center. The other modules will set upon the center module from either end.

1. Place blocks that will set the modules at a height slightly less than the finished height as safety blocks, or for setting modules on.
2. Lift the center module to a location above the four center load cell base plates.

OPTION 1: You may set the module directly on the locating tools and the blocks will act as safety stands.

- Install a Load Cell Bearing Cup with into the upper receiver of each corner, grease will help hold the cup in place.
- Insert the upper end of the locating tool over the upper cup on the module.
- Lower the module while holding the locating tool upright and guiding the bottom of the tool into the lower cup.
- When the center module is set on all four locating tools, keep tension on the cables until the module is centered and straight.
- Use hydraulic jacks to lift the unit slightly and shift the base plates to get the locating tools PLUMB and the top and bottom flanges FLUSH with the sides of the cup.

OPTION 2: Set the modules on the blocks first, then onto locating tools.

- When the module is set on the blocks, keep tension on the cables until the module is properly aligned.
 - Use hydraulic jacks to lift the unit slightly, then install the locating tools. Shift the base plates to get the tools PLUMB and FLUSH with the sides of the cup.
3. Measure from each side of each end of the module to the end walls to be certain the module is plumb and square before removing tension.

4. Once the tension on the lift cables is released, remove the lifting brackets and/or hooks.

2.5.3. Setting the End Modules (Cover Plate Model)

1. **Interlocking Pin** - Drive an interlocking pin into each load cell bracket of the center module.

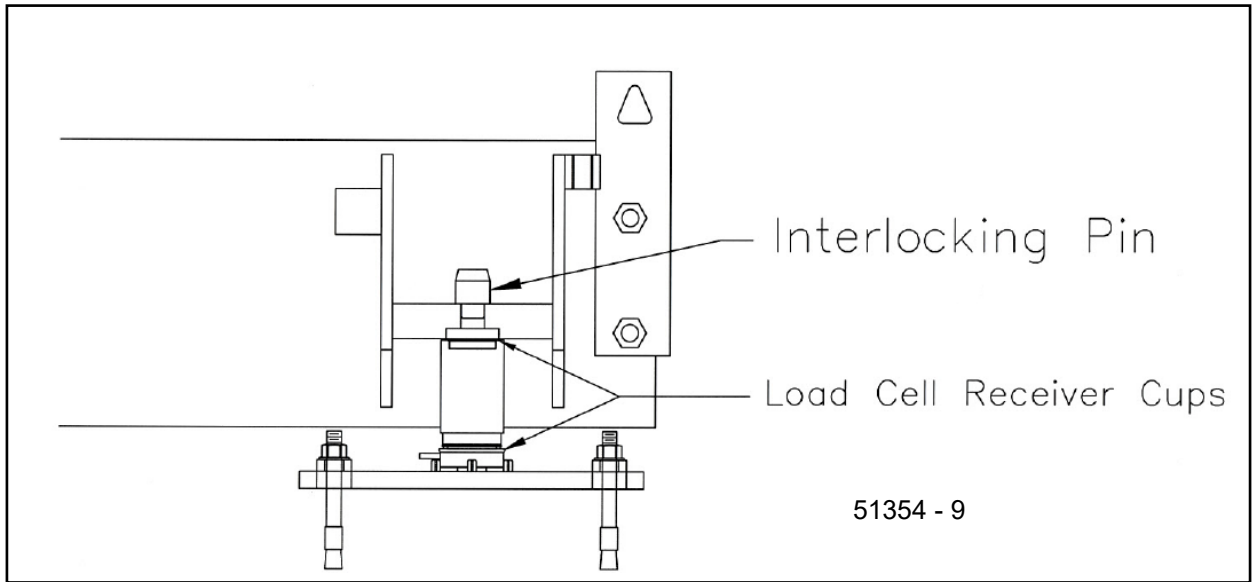

2. **Module Placement** - Guide the modules into place with the supporting blocks on the end of the module coming to rest on the center module load cell bracket interlocking pins. Lower the other end of the module onto the load cell locating tools or blocks.

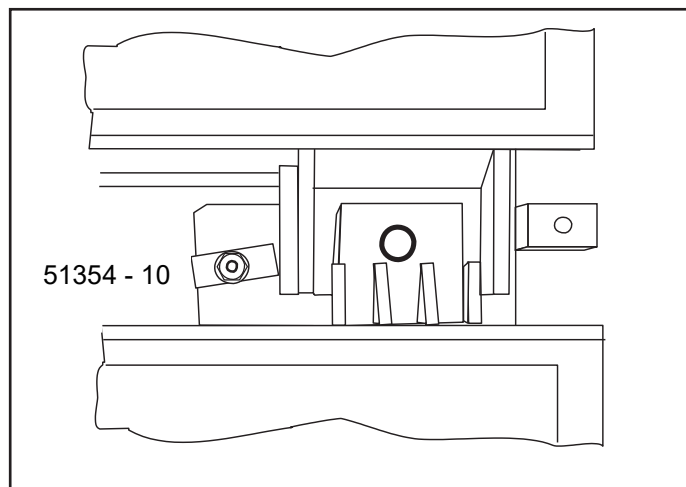

3. Before releasing tension on the cables, check the alignment of the end modules to the center module and to the end wall.

- Ensure end modules are aligned with the center module and the foundation.

2.5.4. Connecting the Modules (Cover Plate Model)

Bolt the modules' channels together using the ½" x 4" x 6" spacers and 1" x 3" bolts. Insert the ½" x 4" x 6" spacer plates between the channels. The bolts go through the back-to-back channels and the spacer. Snug the bolts, but do not tighten them yet.

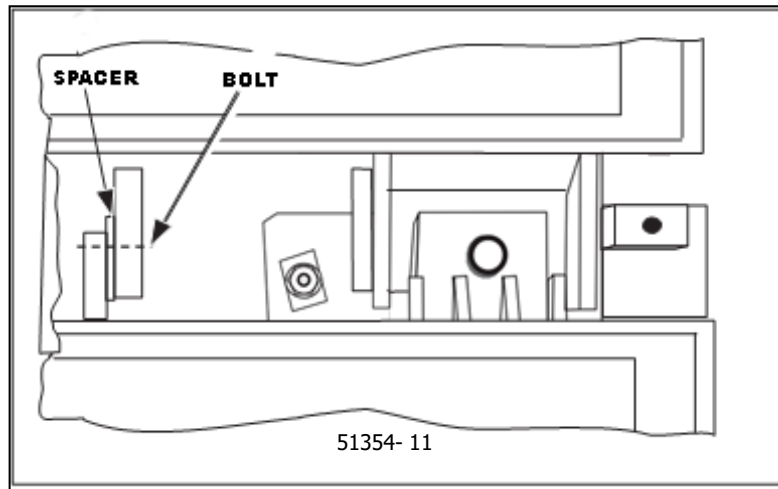

2.5.5. Checking Adjustments (Cover Plate Model)

1. **Adjust End Checking** - Use the end checking shims provided to adjust end checking so that they touch and prevent movement.

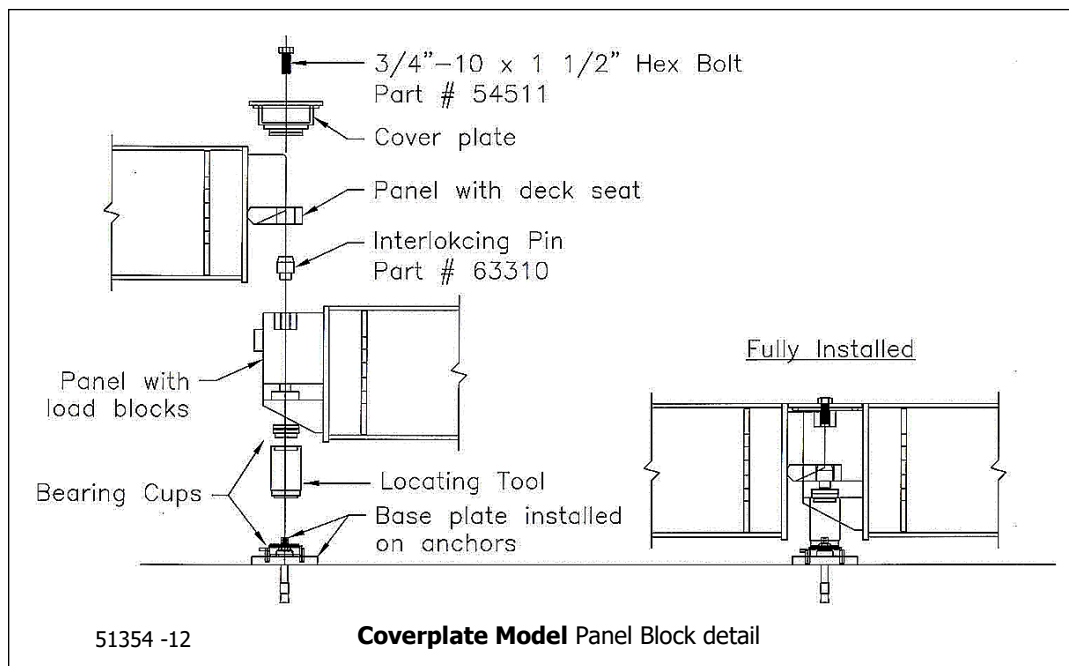

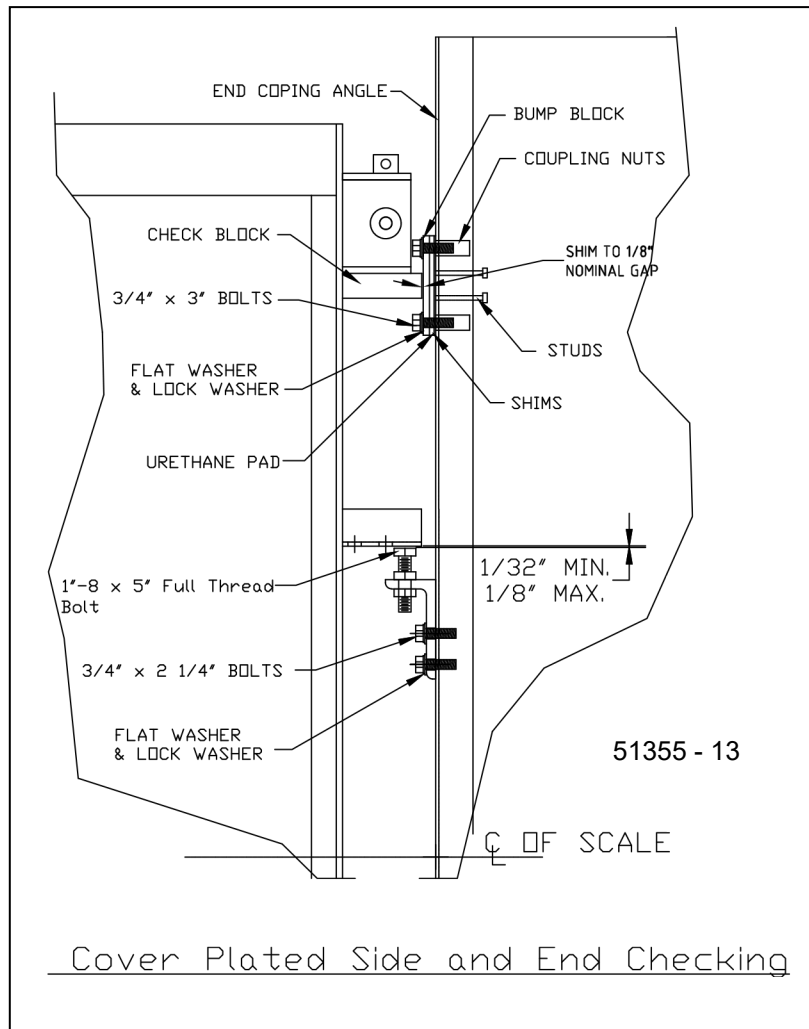

2. Install the side checking brackets:

- Bolt the brackets onto the end copings per the Certified drawings.
- Set the bolts so that they touch the channels they bump against.

3. Base Plate Completion:

- Check that all locating tools are properly aligned and flush with the receiver cups. Drill the holes for the base plate anchors using a hammer-drill and the 5/8" drill bit. Clean out the holes with compressed air. Tap the anchors into clean holes and tighten the nuts securely.

NOTE: *Field-Pour scales are poured, formed and cured with locating tools in place. Do NOT install load cells until cure strength is reached, typically 28-30 days. Use a core sample to confirm.*

4. Installing Load Cells:

- a. Unpack the load cells and mark each calibration certificate with the cell location/position.
- b. Starting at one end of the assembled platform, place hydraulic jacks at the corners so the section can be lifted off the locating tool (2 hydraulic jacks may be required).
- c. Lift the platform so the load cell locating tool can be removed from the upper and lower bearing cups. Once removed, fill both cups with grease, provided with the load cell(s).

CAUTION: *Always wear eye protection!!*

- d. The cell has must be aligned with the flats in the lower cup. Carefully lower the scale (hydraulic jacks) while seating the bottom of the cell into the lower cup.

NOTE: *Anti rotation must be positioned to the **inside** of the scale.*

Check the scale's level and height, particularly at the approaches. Use the load cell shims provided to adjust load cell cups for correct height and to ensure that all cells share the proper amount of load. Center section cells will have up to twice the deadload of end section cells.

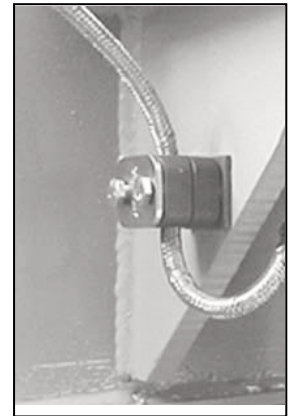

- e. Once satisfied with height and level, tighten the module-to-module bolts.
 - The bolts should be torqued to 690 ft lbs.
- f. Load cell cables:
 - Route the load cell cables through the holes in the channels to the SSC/PPS mounting bar location in the center. Install the strain relief 'clamps' for load cell cables on the strain relief base that is welded onto the scale.

5. Final Checking Adjustment:

- a. Adjust End Checking
 - Remove shims on end checking to allow $\frac{1}{16}$ " to $\frac{1}{8}$ " clearance.
- b. Adjust side checking bolts to allow $\frac{1}{16}$ " clearance from channel.

2.6. Installing Load Cells



1. Unpack the load cells and mark each calibration certificate with the load cell location/position.
2. Starting at one end of the assembled platform, place hydraulic jacks at the corners so the section can be lifted off the locating tool.
 - Two (2) hydraulic jacks may be required.
3. Lift the platform so the load cell locating tool can be removed from the upper and lower bearing cups.
4. Once removed, coat both cups with the grease provided with the cell.
5. Carefully lower the scale (hydraulic jacks) while seating the bottom of the cell into the lower cup.
 - a. Check the scale's level and height, particularly at the approaches.
 - b. Use the load cell shims provided to adjust load cell cups for correct height and to ensure that all cells share an equal amount of the load.
 - c. Center section cells will have up to twice the dead load of end section cells.
6. Once satisfied with height and level, tighten the module-to-module bolts.
 - Torque the nuts to **500 ft./lbs.**

2.6.1. Load Cell Cables

Cable protection on truck scales is extremely important to the reliability of the scale.

- It is imperative for all cables to be installed **off the ground**, and **out of sight**.
- The Trident truck scale has been designed to accommodate this type of cable protection. Route the load cell cables through the conduit that runs laterally through the webs of the stringer beams.

- Route the junction box interface cables through the conduits that run longitudinally along the inside web of main side beams.

2.6.2. Cable Hangers

Behind every SSC or PPS mounting block is a cable hanger.

- These cable hangers are used to hang excess load cell and interconnecting cables.

2.6.3. Complete Installation

1. Once all cables have been run and wiring is complete, tighten all the cables and hang them on the cable hangers to get them out of sight and off the ground.
 - For complete wiring guide, see **Section 3**
2. In a correct installation, the only cables visible are those coming out of the holes in the side beam to the SSC or PPS.

2.6.4. Installing Load Cells – Undermount Model Diagram

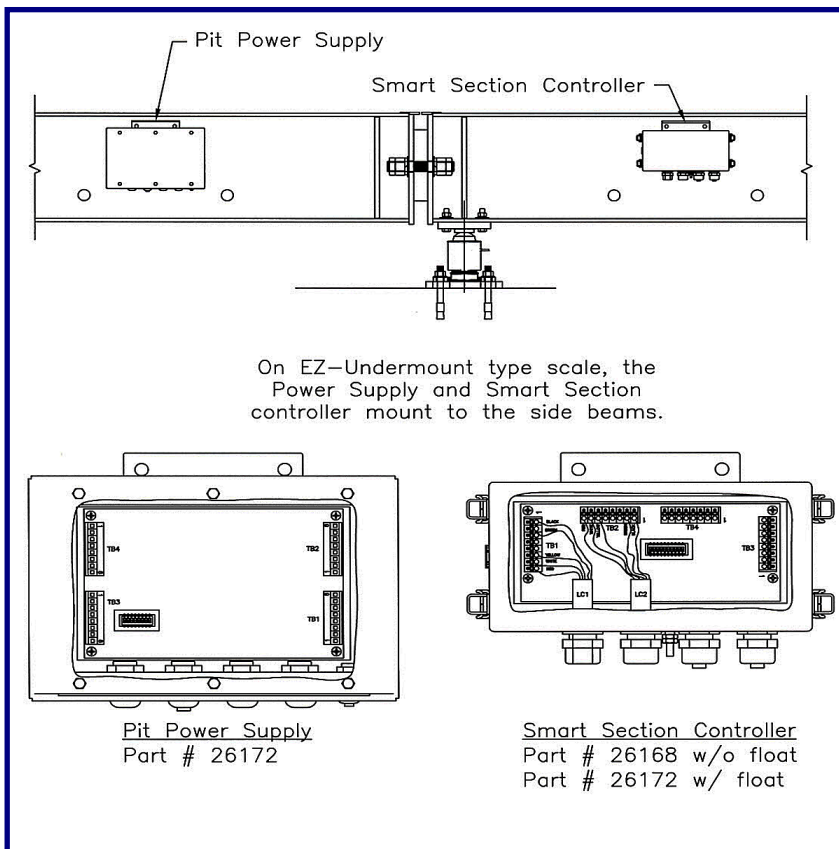

2.6.1. Installing Load Cells - Cover Plate Model Diagram

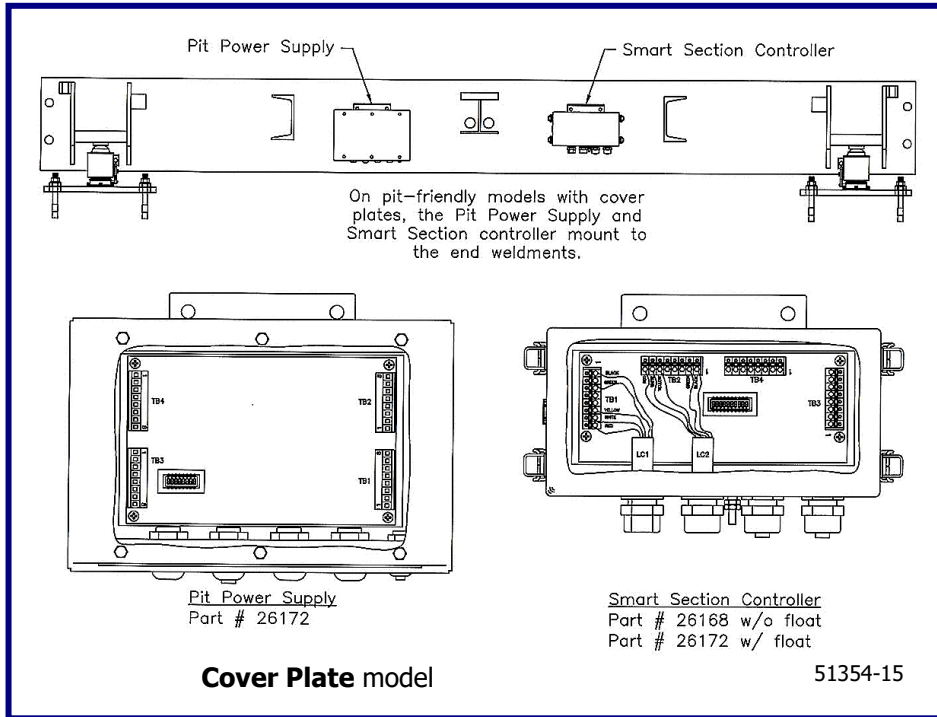

2.7. Analog Balance Box (21912) Installation

The **ANALOG BALANCE BOX** installs at the platform, one box per section.

- All Tridents Instruments come standard with Intalogix.
- Each stainless-steel balance box has four (4) terminal blocks to connect two (2) load cells. Two (2) cables connect the analog instrument.
- Load cells and sections are adjusted using adjusting potentiometers.

2.7.1. Boxes

Follow these steps to mount the **ANALOG MODEL BOX**.

- 1a. Bolt the Box thru the tabs on their side into the mounting brackets of the modules.

- See *Figure 51354-10*.

OR...

- 1b. If the Box is Cover Plated, fasten it under each sectional cover plate.

- See *Figure 51354-11 on the previous page*.

2. Attach the ground wire lug to one of the mounting bolt studs and tighten it securely to provide a good electrical ground.

2.7.2. Wiring

Cable used in all wiring must be a minimum of **18 AWG**.

- Use cable **17204** or equivalent.
3. Interconnect the Balance Boxes from **TB1-to-TB2**, or **TB2-to-TB2**.
 - Beginning at the **end section** where the interface cable conduit enters the scale. If the conduit enters the scale in the middle, an alternate method is to use **14478 INSTRUMENT SVP**.
 - This allows separate connections to go in each direction toward the ends of the scale.
 - See **Bulletin 50513** for complete wiring diagrams.
 4. Adjust the end checking bolts to $1/16$ " - $1/8$ " clearance.
 5. Adjust side checking bolts to allow $1/16$ " clearance from bumper block.

SECTION 3: ELECTRICAL INSTALLATION

3.1. Load Cell Wiring Color Codes

4 1¹/₁₆" RC 30t (66,000 lbs.) Load Cell PR6221/30t C3F (173115)

| | |
|---------------|----------------|
| BLUE | (-) EXCITATION |
| RED | (+) EXCITATION |
| GRAY | (-) SIGNAL |
| GREEN | (+) SIGNAL |
| YELLOW | SHIELD |

3.2. Wiring – 21912 Analog Junction Box

Cells to J-Box 21912 – 1 box per section

| POSITION | | TB3 | TB4 |
|----------|---------------|---------|---------|
| 1 | BLUE | (-) EXC | (-) EXC |
| 2 | RED | (+) EXC | (+) EXC |
| 3 | YELLOW | SHIELD | SHIELD |
| 4 | GREEN | (+) SIG | (+) SIG |
| 5 | GRAY | (-) SIG | (-) SIG |

J-Box to J-Box

| POSITION | | TB1 OR TB2 | TO | TB2 (second box) or TB1 |
|----------|---------------|------------|----------------|--------------------------|
| 1 | BLACK | (-) EXC | | (-) EXC |
| 2 | GREEN | (+) EXC | | (+) EXC |
| 3 | BLUE | (+) SENSE | MUST BE | (+) SENSE MUST BE |
| 4 | ORANGE | (-) SENSE | USED | (-) SENSE USED |
| 5 | N/C | N/C | | N/C |
| 6 | SHIELD | SHIELD | | SHIELD |
| 7 | WHITE | (+) SIG | | (+) SIG |
| 8 | RED | (-) SIG | | (-) SIG |

Instrument to J-Box

| POSITION | TB1 OR TB2 |
|----------|------------|
| 1 | (-) EXC |
| 2 | (+) EXC |
| 3 | (+) SENSE |
| 4 | (-) SENSE |
| 6 | SHIELD |
| 7 | (+) SIG |
| 8 | (-) SIG |

3.3. Wiring Guide

The Trident Truck Scale is designed to provide protection against moisture.

- The load cells are calibrated with the cable attached.
- The cable should **NEVER be cut**.

Load cell cables connect directly to the balance box or SSC through a sealed bushing.

- This **MUST be tightened properly** to keep water/moisture out of the box.
- All cabling should have a **drip loop** at the cell or box entry location to help prevent water entry.

On all boxes, particularly stainless steel, the black plastic fittings have connectors that can be forced out of position if the bushing itself is not tight.

- Prevent this by first tighten the inner nut securing the bushing in the hole, then insert cable and carefully tighten the gland snugly.
- Do not over-tighten where the bushings attach.
- Fasten the cover securely.

Balance boxes must have one (1) ground rod in the pit for proper grounding.



3.3.1. Instrument cable connection, balance box

The two (2) cables from the two (2) center section boxes enter the **Instrument SVP (14478)** and terminate there. The cable from the instrument connects at instrument SVP as well.

- Prepare the cable ends in the standard manner.
- Use Appendix II for wiring instructions of all pit balance boxes.
- Connect the Instrument Interface Cable to the instrument in the scale house according to the instructions in the appropriate instrument service manual.

3.3.2. Adjusting Cells/Sections

Whenever possible, install load cells of matching outputs in sections to reduce side-to-side errors.

- When calibrating, place weights directly over the cell or directly on the section being tested.
- Adjust the potentiometers for the correct cell or section to compensate for differences.

3.4. Wiring SSCs and PPSs for Intalogix systems

Intalogix™ Systems use Smart Sectional Controllers (SSCs) and Pit Power Supplies (PPSs) for load cell excitation and signal processing.

- There is one (1) SSC per section, and one (1) PPS for the entire platform.
 - This is unless the number and resistance of the cells require a second pit power supply.
- SSC boxes have four (4) terminals.
 - Two (2) are for load cells and two (2) for interconnecting to other SSC boxes or terminating to a pit power supply.
 - All cell, section, and scale adjustments are made using the Intalogix system instrument.

*Follow these tips for mounting the **PPSs** and **SSCs**.*

- Bolt the Box thru the tabs on their side into the mounting brackets of the modules.
- Cable used in all wiring must be a minimum of **18 AWG**.
 - Use cable **17204** or **17246**.
- Use appropriate service manual for the instrument being installed.
- *For further instructions, see **APPENDIX III**.*

3.4.1. Intalogix Load Cell Numbering

Intalogix installations utilize a different numbering system for load cells because of digital addressing of the SSCs. Number the load cells as described below.

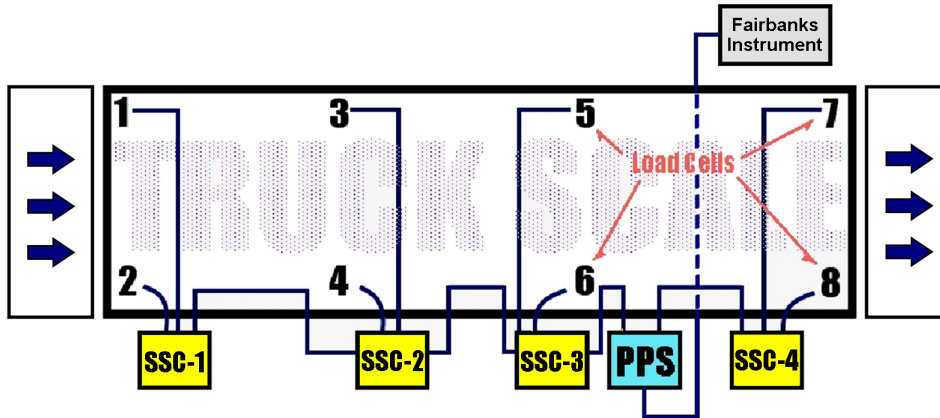

Face the platform with the **Inbound traffic** on the *left*. The cell at the **upper-left** (far side) of the platform is **Cell 1**.

- The cell positions along the far side will be odd cell number, and the near side locations will be even cell numbers.

SSCs have connections for two (2) load cells, **TB1** and **TB2**.

- The odd-numbered cell should go to the TB1 connection, and the even-numbered cell to the TB2 connection.

3.4.2. Grounding SSCs

Intalogix® systems must have **two (2) ground rods** in the pit for proper connection.

- Pit power supplies use a ground separate from the steel and SSC ground rod.

3.4.3. Instrument-to-PPS Cable Connection

Prepare the cable ends in the standard manner.

- Use the appropriate manual for wiring instructions of all pit SSCs and power supplies.
- Connect the instrument interface cable to the instrument in the in the scale house per the instructions in the appropriate indicator service manual.

3.4.4. Wiring – Intalogix Junction Box

CELLS TO SMART SECTIONAL CONTROLLER (SSC)

| POSITION | | TB1 | TB2 |
|----------|---------------|---------|---------|
| 1 | BLUE | (-) EXC | (-) EXC |
| 2 | RED | (+) EXC | (+) EXC |
| 6 | YELLOW | SHIELD | SHIELD |
| 7 | GREEN | (+) SIG | (+) SIG |
| 8 | GRAY | (-) SIG | (-) SIG |

SSC TO SSC OR SSC TO PIT POWER SUPPLY

| POSITION | | TO TB3 | FROM TB4 |
|----------|---------------|-----------|-----------|
| 1 | BLACK | (-) 8 VDC | (-) 8 VDC |
| 2 | GREEN | (+) 8 VDC | (+) 8 VDC |
| 5 | BLUE | DC RETURN | DC RETURN |
| 6 | SHIELD | SHIELD | SHIELD |
| 7 | WHITE | (+) RS485 | (+) RS485 |
| 8 | RED | (-) RS485 | (-) RS485 |

PIT POWER SUPPLY TO INSTRUMENT

| POSITION | | TB1 (PPS) | TO TB1 (INSTRUMENT) |
|----------|---------------|------------------|---------------------|
| 1 | BLACK | (-) 28 VAC | (-) 28 VAC |
| 2 | GREEN | (+) ACR | (+) ACR |
| 3 | BLUE | (+) 20 VDC | (+) 20 VDC |
| 4 | ORANGE | (-) ENABLE 5 VDC | (-) ENABLE 5 VDC |
| 6 | SHIELD | DC RETURN | DC RETURN |
| 7 | WHITE | (+) RS485 | (+) RS485 |
| 8 | RED | (-) RS485 | (-) RS485 |

SECTION 4: SERVICE & MAINTENANCE

4.1. Scale Maintenance

1. Check for accumulations of solid material under the scale, which may affect the accuracy (ice, frozen mud, debris).
2. Check to see that the customer has cleaned under the platform regularly.
3. Inspect load cells for damage to the ends/cables; check cups for damage and/or excessive or uneven wear.
4. The load cell bearing cups should be inspected, cleaned, and greased at least TWICE per year.
5. Inspect and adjust all check bolts using anti-seize on the threads.
6. Inspect and tighten all connecting and coverplate hardware for proper tightness.

4.2. Mechanical Faults

1. Check for all clearances around the scale for any obstructions or interference with the free movement of the platform.
2. Check all check bolt clearances both with and without a concentrated load over each section, one at a time.
3. Check all load cells for plumb and level.
4. Inspect the boxes for leaks; the interior should be clean and dry. If there is moisture inside, clean and dry it thoroughly. Check all connections at the terminal blocks to ensure they are tight.

4.3. Replacing a RC Load Cell

1. Remove power from the instrument.
2. Lift the scale using a proper sized and rated hydraulic jack (or jacks) at the corners closest to the defective load cell location.

WARNING!

Lift the scale platform(s) *ONLY* at the *CORNERS*!
On factory pour scales, use two (2) properly rated hydraulic jacks at opposite sides, and at the corners, lifting the scale in this manner.
 Place hydraulic jacks ***ONLY*** at the ***CORNERS*** of the modules.
 Hydraulic jacks must be placed on opposite sides to lift the module in a level position. Lifting mid-span or between load cells will cause cracks in the concrete!

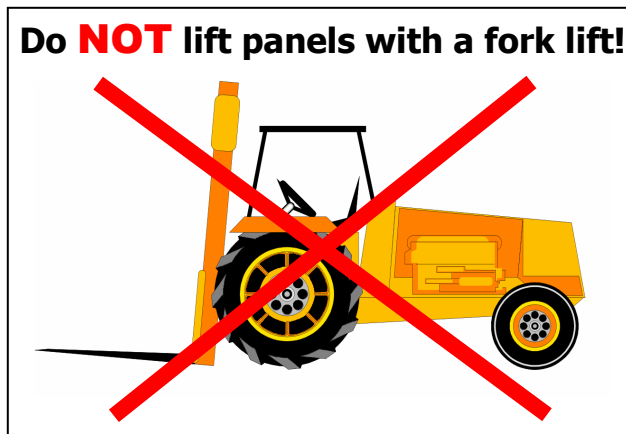

3. Check upper and lower receiving cups for damage. Replace as necessary and reapply grease.
4. Insert the new cell into the upper receiving cup and position the anti-rotation pin.
5. Carefully lower the hydraulic jack(s) until the cell is set into the lower cup.
6. Remove the cover of the SSC/J-box, then loosen the gland bushing to free the cable. Remove the old cell wires and connect new cell wires in the balance box/SSC. Secure the cover.
7. Test and adjust the scale as necessary.

4.3.1. Load Cell Specifications

Load cell part number: **173115**

Description: 4 1¹/₁₆" – 2.4mV/V, 66k or 30t, 1000 Ω

SECTION 5: PARTS

5.1. Platform Parts List

| PART NO. | DESCRIPTION |
|----------|--|
| 54511 | 3/4" – 10 x 1 1/2" hex bolt for cover plate model only |
| 63310 | Interlocking pin – cover plate model only |
| 64213 | Bumper block – cover plate model only |
| 157005 | Load cell base plate – cover plate model only |
| 61380 | Side checking – cover plate model only |
| 54304 | Hex nut, 1 1/8" – 7 – undermount model only |
| 54891 | Jam nut, 1 1/8" – 7 – undermount model only |
| 76708 | 1 1/8"-7 x 8" threaded rod, zinc (module-module) – undermount model only |
| 54788 | 1 1/8" lock washer (module-module) – undermount model only |
| 54255 | 1 1/8" flat washer (module-module) – undermount model only |
| 156965 | Load cell base plate – undermount model only |
| 75398 | Side check bracket – undermount model only |
| 61743 | Clamp bar washer (base plates) |
| 62857 | 5/8" x 6" anchor bolts (wedge type) |
| 55010 | Dual ground rod kit |
| 147922 | Lifting eye bolt |
| 54310 | 1 1/4" – 7 – hex nut for eye bolt |
| 79747 | Rub Rail PVC End Caps |
| 105297 | Rub Rail Plugs |

5.2. Load Cell Parts

| PR6221/30t C3F | |
|----------------|--|
| PART NO. | DESCRIPTION |
| 173115 * | Load cell, 4 11/16" RC, 66k, 1000 Ω, 2.4 mV/V |
| 161197 | Upper & Lower Cup (With Anti-Rotation Pin) Kit with Gasket |
| 157278 | Roll pin, 3/8" X 1-1/4", Cup Retainer |
| 157069 | Locating tool, 4 3/4" (optional) |
| 161398 ** | Shim, Upper Cup, 1/8" (2.25" OD) |
| 161397 ** | Shim, Lower Cup, 1/16" (2.75" OD) |

* Includes Upper and Lower Cups

** See image (right)

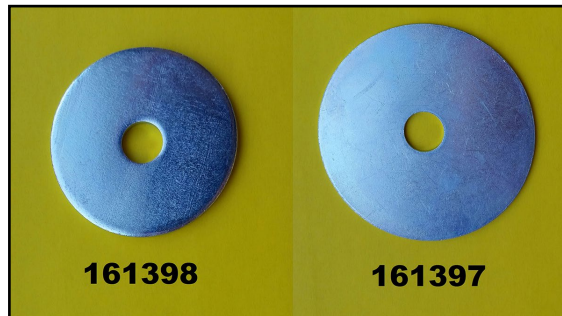

5.3. Rub Rails

Available in factory-installed and field-installed types.

Field-installed rub rail installation:

- Use the print with the accessory for actual measurements.
- Bolt the gussets to the stiffeners and end weldments.

WARNING!

Fairbanks does NOT recommend using **Foundation-Mounted Rub Rails** along the sides of this truck scale platform.

Damage may occur to the scale if a truck hits the Rub Rail, transferring damaging force to the platform and checking system.

Using these type of Rub Rails will

VOID THE PRODUCT WARRANTY!

5.4. Spare Parts

5.4.1. Recommended Spare Parts

| Part No. | Qty | Description |
|----------|-----|--|
| 173115 | 1 | Load Cell, 411/16" RC, 30t (or 66k) |
| 161197 | 1 | Upper & Lower Cup (with anti-rotation pin) kit |

5.4.2. Startup / Commissioning Spare Parts

| Part No. | Qty | Description |
|----------|-----|--|
| 173115 | 1 | Load Cell, 411/16" RC, 30t (or 66k) |

5.4.3. 2-Year Spare Parts List

| Part No. | Qty | Description |
|----------|-----|--|
| 173115 | 1 | Load Cell, 411/16" RC, 30t (or 66k) |
| 161197 | 1 | Upper & Lower Cup (with anti-rotation pin) kit |
| 79747 | 1 | Rub Rail PVC End Caps |
| 105297 | 1 | Rub Rail Plugs |

Capital Spare Parts – Not Applicable

APPENDIX I: FOUNDATION CHECKLIST



Foundation Inspection

FOUNDATION FIELD CHECK LIST (Field Form)

A Foundation Inspection **should ALWAYS** be performed prior to scale installation and to **confirm** correct foundation construction. If possible this should be done prior to scale shipment.

- Tools required:**
- Certified drawings and site plan
 - 2' to 4' level
 - 100' and 25' steel tapes
 - Hammer and concrete nails
 - Laser or builders level if possible
 - String line (construction string)
 - Straight edge for pit foundations (2 x 4, very straight and 4" wider than pit walls)
 - Construction paint (up-side-down type, for marking concrete).

Perform the following Foundation Checks. Refer to Methods and Procedures for complete description of each step. Recommended to copy check list and keep in job file. ALWAYS familiarize yourself with the **CERTIFIED** foundation prints for the job you are working on as model numbers and specifications are subject to change.

- 1. **Site Plan and Certified Prints** should be thoroughly reviewed to confirm accurate locations to the scale and all extra items (scoreboards, lights, poles, etc.) that are included in the bid or contract.
- 2. **Check for truck and crane access**, overhead wires, fences, green concrete, etc.
- 3. **Dimensional length and width check**; check all 4 sides and record on chart (other side).
- 4. **Diagonal measurements** check to verify that the foundation is square and record on chart (other side). These measurements should be equal, or within 1/2". Greater error could result in the scale not fitting in the foundation.
- 5. **Check ALL pier heights** to make sure they are the proper elevation and record on chart (other side). To high and the scale will not fit correctly, to low could result in excessive shimming..
- 6. **In pit foundations check walls to verify they are straight.** Straight walls are very important, but are even more critical for modular scales like the Rodan series.
- 7. **Verify conduit locations** and pull strings (if needed).
- 8. **Verify ground rod locations.**
- 9. **Verify that drains and sump openings** are piped correctly and are clear of debris.
- 10. **Check the end coping** to ensure they are centerline and that the coping is correct for the scale being installed (10', 11' or 12' width, etc). Check all coping, side and end, for hollow areas.
- 11. **Verify location of any and all required embeds or pre-installed baseplates** (i.e., Hwy System, RR scales, etc). All of these dimensions will be located on the Certified foundation prints.
- 12. **Layout** - To help in locating pre-installed baseplates, embeds, load-cell centerlines, etc., refer to Methods and Procedures section on Layout. **See other side for foundation & Layout charts.**

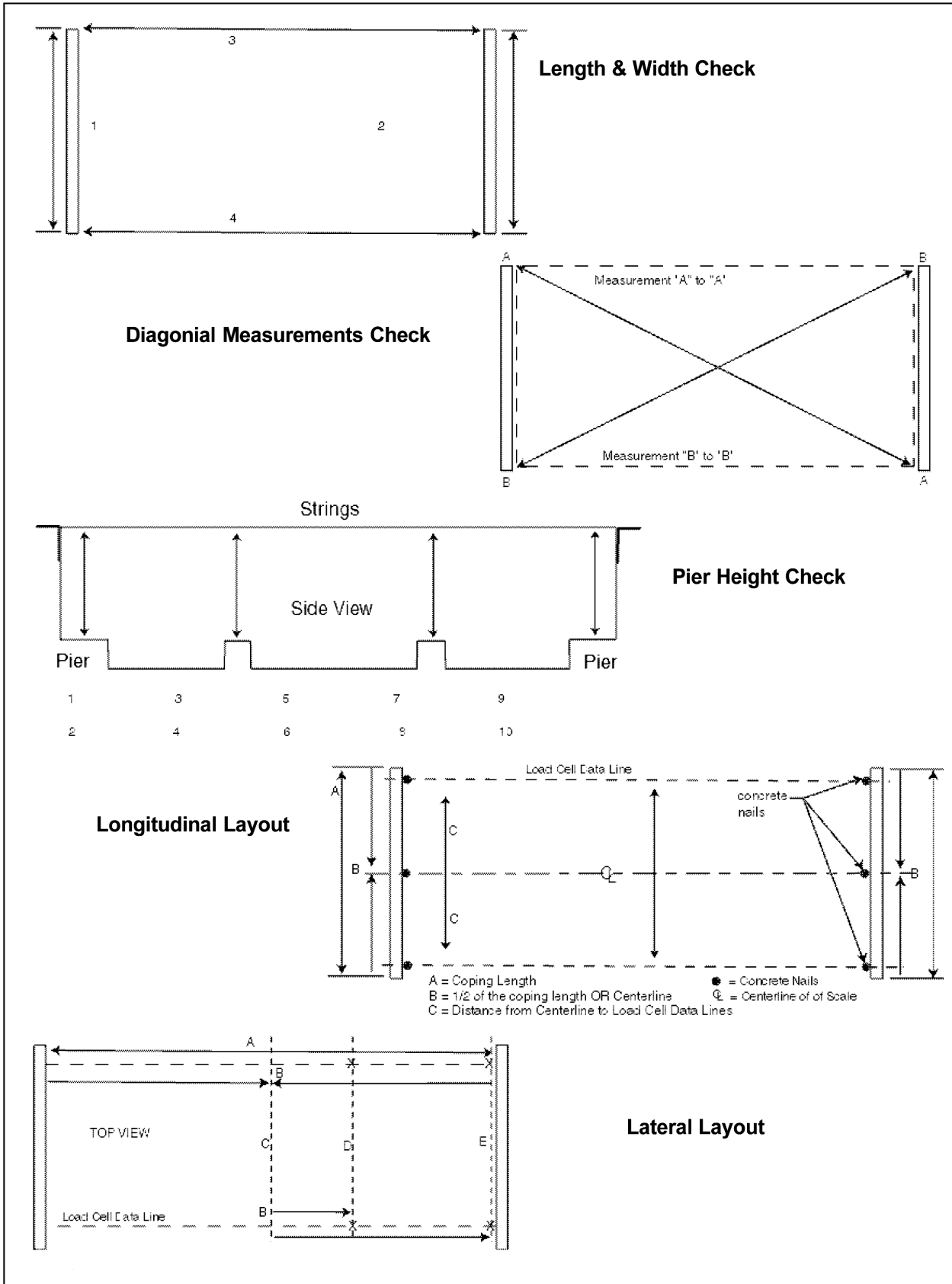

APPENDIX II: PRECAST CONCRETE DECK SPECIFICATIONS

A. Model Number 6030-PC-UM (CP)

| | E. PRODUCT NO. | F. L G. Ft. | H. W I. Ft. | J. CLC K. -lbs | L. CAP M. Tons | N. SEC |
|---------------|----------------|-------------|-------------|----------------|----------------|--------|
| 10 ft. | 163010 | 10 | 10 | 80k | 50 | 2 |
| | 163015 | 15 | 10 | 80k | 50 | 2 |
| | 163020 | 20 | 10 | 80k | 50 | 2 |
| | 163023 | 23 | 10 | 80k | 50 | 2 |
| | 163030 | 30 | 10 | 80k | 75 | 3 |
| | 163040 | 40 | 10 | 80k | 75 | 3 |
| | 163047 | 47 | 10 | 80k | 75 | 3 |
| | 163060 | 60 | 10 | 80k | 100 | 4 |
| | 163070 | 70 | 10 | 80k | 100 | 4 |
| | 163075 | 75 | 10 | 80k | 125 | 5 |
| | 163080 | 80 | 10 | 80k | 125 | 5 |
| | 163090 | 90 | 10 | 80k | 125 | 5 |
| | 163001 | 100 | 10 | 80k | 125 | 6 |
| | 163011 | 110 | 10 | 80k | 125 | 6 |
| | 163018 | 117 | 10 | 80k | 125 | 6 |
| 163021 | 120 | 10 | 80k | 125 | 7 | |
| 11 ft. | 163110 | 10 | 11 | 80k | 50 | 2 |
| | 163115 | 15 | 11 | 80k | 50 | 2 |
| | 163120 | 20 | 11 | 80k | 50 | 2 |
| | 163123 | 23 | 11 | 80k | 50 | 2 |
| | 163130 | 30 | 11 | 80k | 75 | 3 |
| | 163140 | 40 | 11 | 80k | 75 | 3 |
| | 163147 | 47 | 11 | 80k | 75 | 3 |
| | 163160 | 60 | 11 | 80k | 100 | 4 |
| | 163170 | 70 | 11 | 80k | 100 | 4 |
| | 163175 | 75 | 11 | 80k | 125 | 5 |
| | 163180 | 80 | 11 | 80k | 125 | 5 |
| | 163190 | 90 | 11 | 80k | 125 | 5 |
| | 163101 | 100 | 11 | 80k | 125 | 6 |
| | 163111 | 110 | 11 | 80k | 125 | 6 |
| | 163118 | 117 | 11 | 80k | 125 | 6 |
| 163121 | 120 | 11 | 80k | 125 | 7 | |

APPENDIX III: WIRING DIAGRAMS

A. Trident Precast Concrete Deck Typical Installation Wiring Diagram – Analog

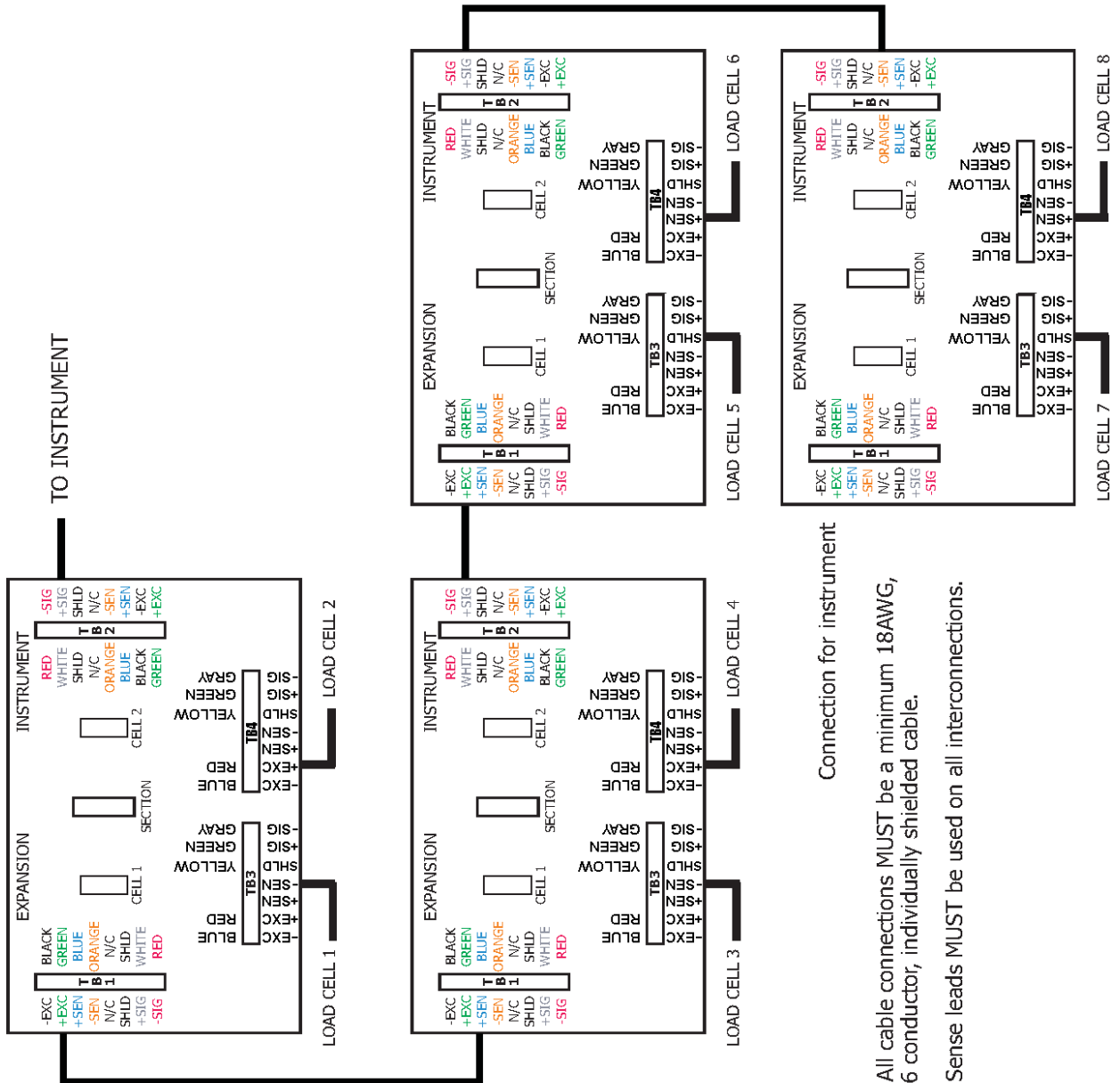

- All cable connections **MUST** be a minimum 18AWG, 6 conductor, individually shielded cable.
- Sense leads **MUST** be used on all interconnections.

B. Trident Precast Concrete Deck Typical Installation Wiring Diagram - Intalogix

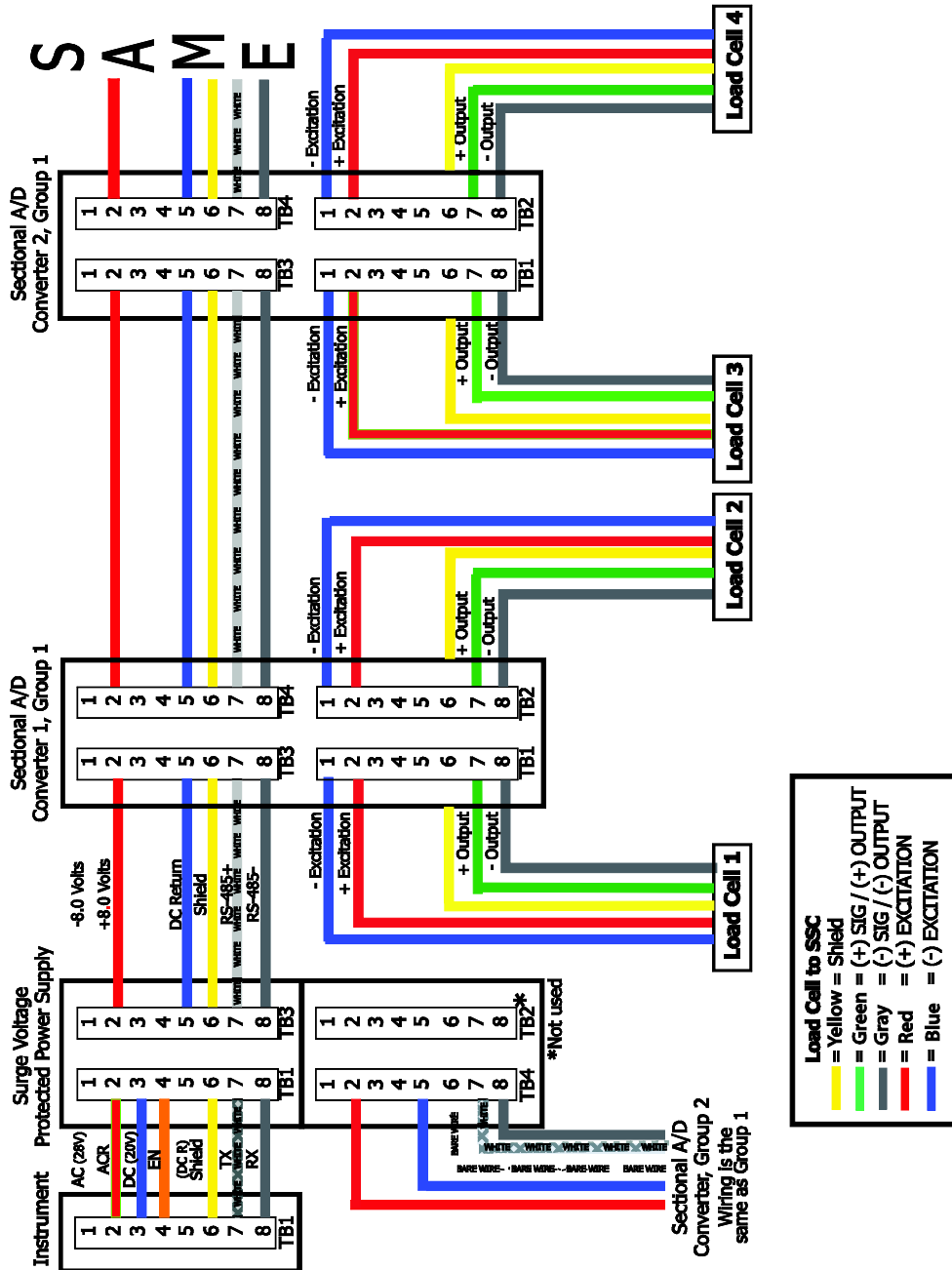



Fairbanks Scales Inc.

www.fairbanks.com

Trident Precast

Concrete Deck Truck Scale

Document 51354