

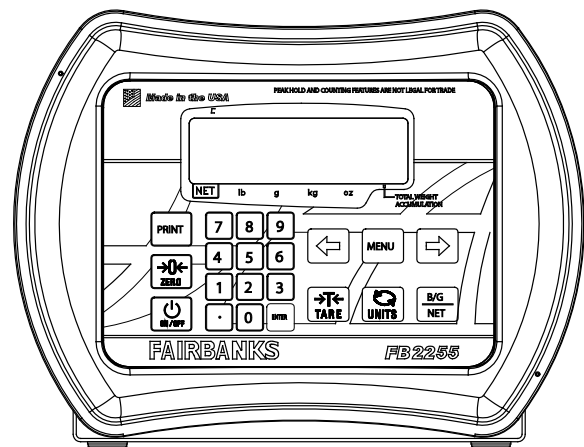

FB2255 Series Instrument

PC2255

PC Software Utility Program

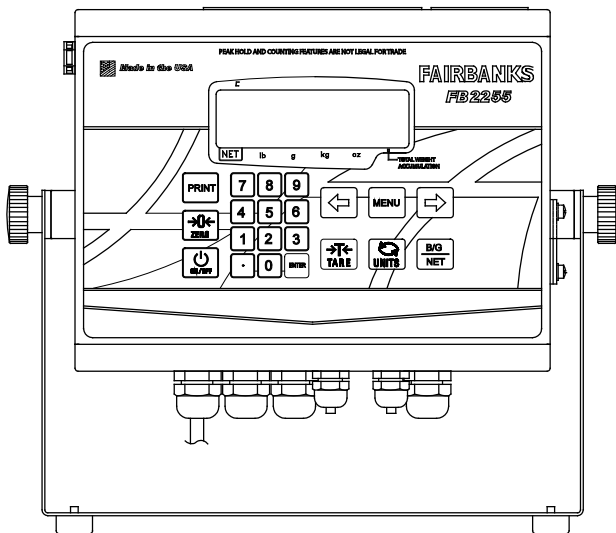

Amendment Record

FB2255 Series **Document 51297**

Manufactured by Fairbanks Scales Inc.

Created	07/2012	
Revision 1	01/2013	
Revision 2	05/2015	Updated specifications and fieldbus data. Added FB225X TCP configuration instructions.
Revision 3	08/2015	Updated Fieldbus information
Revision 4	08/2016	Added Modbus information+
Revision 5	03/2016	Updated Weight Accumulation
Revision 6	04/2016	Added TM-U220 Tape Printer Information
Revision 7	08/2017	Updated front panel programming steps
Revision 8	10/2017	Updated model descriptions in the General Information section
Revision 9	01/2019	Updated weight accumulator capacity; Updated 4-20mA programming
Revision 10	01/2019	Added instructions for a monorail feature
Revision 11	10/2019	Added 4-20mA "Warning" information
Revision 12	02/2020	Updated Fieldbus links
Revision 13	08/2020	Updated Weight Accumulations

Disclaimer

Every effort has been made to provide complete and accurate information in this manual. However, although this manual may include a specifically identified warranty notice for the product, Fairbanks Scales makes no representations or warranties with respect to the contents of this manual, and reserves the right to make changes to this manual without notice when and as improvements are made.

It is the responsibility of the requesting party to develop, maintain, install, and connect networking devices and general network connectivity as it applies to the originating party's network. No warranty or guarantee, expressed or implied, concerning the network, its design, its installation, or operational characteristics has been offered by Fairbanks Scales. Fairbanks Scales shall not be liable for any loss, damage, cost of repairs, incidental or consequential damages of any kind, whether or not based on express or implied warranty, contract, negligence, or strict liability arising in connection with the design, development, installation, or use of an intended network.

The Bluetooth® word mark and logos are owned by the Bluetooth SIG, Inc. and any use of such marks by Fairbanks Scales is under license. Other trademarks and trade names are those of their respective owners.

© Copyright 2012-2020

This document contains proprietary information protected by copyright. All rights are reserved; no part of this manual may be reproduced, copied, translated, or transmitted in any form or by any means without prior written permission of the manufacturer.

Table of Contents

SECTION 1: GENERAL INFORMATION	7
1.1. Model Descriptions	7
1.2. Main Product Features	7
1.3. Specifications	8
1.3.1. Instrument Approvals	8
1.3.2. Basic Specifications	8
1.3.3. Standard Settings	9
1.3.4. Weight Accumulator	9
1.3.5. Outputs	9
1.3.6. PC2255	9
1.3.7. Power Requirements	9
1.3.8. DC Models	10
1.3.9. Out of Range Warnings	10
1.3.10. External Printers	10
1.3.11. Environment	10
1.4. Accessories	11
1.5. AC Operation	12
1.6. Powering up the FB2255	12
SECTION 2: USER OPERATIONS	13
2.1. Front Panel Key Functions	13
2.2. Front Panel Programming Parameters	14
2.2.1. Setting and Programming the Time	14
2.2.2. Programming the Date	14
2.2.3. Checking Power Supply / Battery Voltage	15
2.2.4. Programming the Sleep Function	15
2.3. Operating Procedures	15
2.3.1. Programming Port 1	16
2.3.2. Programming the Port 1 Output Type	16
2.3.3. Programming Port 1 Baud Rate	16
2.3.4. Programming Port 1 Data Bits	17
2.3.5. Programming Port 1 Parity Setting	17
2.3.6. Programming Port 1 Stop Bits	17
2.3.7. Programming Port 2	18
2.3.8. Programming the Port 2 Output Type	18
2.3.9. Programming Port 2 Baud Rate	18
2.3.10. Programming Port 2 Data Bits	19
2.3.11. Programming Port 2 Parity Setting	19
2.3.13. Programming Port 2 Stop Bits	19
2.3.14. Programming the Back Light Options	20
2.3.15. Programming the Back Light Timing	21
2.4. Gross, Tare and Net Weight	21
2.5. Basic Weighing	21
2.6. Gross Weighing	22
2.7. Net Weighing	22
2.8. Gross/Tare/Net Weighing	22
2.9. Weight Accumulation	23
2.9.1. Weight Accumulation	23
2.9.2. Printing Weight Accumulations	23
2.10. Number of Accumulations	26



- 2.11. Clearing the Accumulators 26
- 2.12. Piece Counting 28
- 2.13. Piece Count and Total 29
- 2.14. Peak Weight 30
- 2.15. Monorail..... 30
- SECTION 3: SERIAL COMMUNICATION WIRING 31**
 - 3.1. JP3 Jumper Configuration)..... 31
 - 3.2. TB4 Wiring connections, COM1 (A), COM2 (B), and COM2 (C) 32
 - 3.3. TB5 Remote Switch Inputs 32
 - 3.4. Remote Display Active Keys 33
- SECTION 4: INPUT / OUTPUT 34**
 - 4.1. 3550 Tape Printer 34
 - 4.2. TM-U220 Tape Printer 34
 - 4.3. Okidata 186 T Form Printer 35
 - 4.4. Okidata 420 Form Printer 39
 - 4.5. TM-U295 Ticket Printer 42
 - 4.6. TM-U590 Ticket Printer 42
 - 4.7. Remote Display 43
 - 4.8. 4-20mA Analog Output Setup..... 44
 - 4.8.1. Programming the 4mA Weight Value 45
 - 4.8.2. Programming the 20mA Weight Value 45
- SECTION 5: FIELDBUS/BLUETOOTH 46**
 - 5.1. Fieldbus Installation..... 46
 - 5.2. Fieldbus Connections 47
 - 5.2.1. Overview of Terms..... 47
 - 5.2.2. DeviceNet™ (29578) 49
 - 5.2.3. ControlNet™ (31979)..... 51
 - 5.2.4. Profibus®-DP (29576) 53
 - 5.2.5. MODBUS TCP (34032) 55
 - 5.2.6. Ethernet/IP Diagnostic LEDs 57
 - 5.3. Bluetooth® Technology Device 58
- SECTION 6: PC2255 UTILITY SOFTWARE 61**
 - 6.1. Introduction..... 61
 - 6.2. Communication Settings 61
 - 6.3. Communication Files..... 63
 - 6.4. Menu Bar 63
 - 6.5. Configuration..... 65
 - 6.6. Calibration..... 66
 - 6.7. First time connection using PC225X PC Utility and FB225X Ethernet TCP/IP option. 66
 - 6.8. Fieldbus..... 71
 - 6.9. 4-20mA..... 74
 - 6.10. Custom Output – Settings 75
 - 6.11. Custom Output – Load 76
 - 6.12. Custom Output – Build..... 76
 - 6.13. Custom Output – Tokens 77
 - 6.14. Custom Output – Weights..... 79
 - 6.15. Formatting Tickets 80
 - 6.16. Printed Examples 81



SECTION 7: SERVICE AND MAINTENANCE 84

 7.1. Troubleshooting the Instrument..... 84

 7.2. Battery Installation 84

APPENDIX I: DATA OUTPUT FORMATS 85

 A. General Notes 85

 B. Fairbanks/ Toledo Continuous Output..... 85

 C. Cardinal 738 Continuous Scoreboard Output..... 88

 D. Weightronics WI-120 Continuous Output..... 88

 E. Condec Continuous Output..... 89

 F. Demand Output - DEFAULT 89

 G. Continuous Output - DEFAULT..... 90

 H. PLC (DO NOT USE)..... 91

 I. UPS 92

 J. P Ship..... 93

APPENDIX II: REMOTE PC COMMANDS 95

APPENDIX III: FB2255 REMOTE DISPLAY WIRING 97

APPENDIX VI: FB2255 REMOTE DISPLAY ACTIVE KEYS 98

APPENDIX VII: FB2255 PANEL MOUNT DIMENSIONS 99

Section 1: General Information

1.1. Model Descriptions

The FB2255 is a general-purpose weighing instrument that can be used with a wide variety of platforms and load receivers, and is available in eight (8) different configurations.

MODEL	PART NO.
FB2255 Series ABS, AC Power	32351
FB2255 Series ABS, AC/Battery Power	32449
FB2255 Series SS, AC Power	32352
FB2255 Series SS, AC/Battery Power	32450
FB2255 Series SS, AC Power, No Bracket	32451
FB2255 Series SS, AC/Battery Power, No Bracket	32452
FB2255 Series SS, AC Power, No Bracket, IP69K	32453
FB2255 Series SS, AC Power, IP69K	32353
FB2255 Series AC Power, Panel Mount	32581

1.2. Main Product Features

Major features of the Instrument include the following.

- ✓ Push-button programming and calibration.
- ✓ Program data is stored in battery supported RAM and backed up in flash memory. The battery should be replaced every twelve (12) months.
- ✓ The FB2255 series instrument features a large one inch (1") green backlit LCD weight display, which can be tilted up or down to accommodate different lighting conditions.
- ✓ Microprocessor controlled design allows the instrument to be rapidly programmed at installation to meet the specific requirements of the application.
- ✓ The obtainable accuracy meets Handbook 44 requirements, and the instrument is approved for **commercial application up to 10,000 divisions**.
- ✓ A **maximum of 100,000 displayed divisions** can be programmed for non-commercial applications.
- ✓ A computer utility software program PC2255 is available, downloaded from Fairbanks Intranet for programming using the computer, and is required for certain features such as custom ticket formatting.

1.2. Main Product Features, Continued

- ✓ The PC2255 software utility program can also upload and modify the instruments set-up, configuration, and calibration.
- ✓ Saved information can be downloaded from a computer to the FB2255 Series in the event of a catastrophic failure.
- ✓ The instrument provides two (2) serial communication ports to provide communication to various types of peripheral devices for RS232, RS422, RS485, and 20mA data outputs.
- ✓ Optional accessories include a 4-20mA analog output, Bluetooth® serial adapter, and five different fieldbus devices; Profibus®, DeviceNet™, ControlNet™, Modbus® and Ethernet/IP.

1.3. Specifications

1.3.1. Instrument Approvals

CC	09-023
MC	AM-5720
ETL	ETL Listed
Conforms to ANSI/UL STD 60950-1	
Certified to CAN/CSA C22.2 STD NO. 60950-1-03	

1.3.2. Basic Specifications

ENCLOSURE	ABS, Black NEMA 1, Stainless Steel NEMA 4X Desk and Wall Mount
DISPLAY	6-digits, One inch (1") LCD, Green Backlight
FRONT PANEL KEYS	On/Off, Units, Zero, B/G, Net, Tare and Print
UNITS	lbs., oz, kg, g and lbs/oz, or custom
GRADUATION SIZE	0.0001 to 50
AD CONVERSION	66 per second
LOAD CELL EXCITATION	5 Volts DC
SENSITIVITY	1µv/d (microvolt/division)
LOAD CELLS	Eight (8) 350 ohm or Sixteen (16) 1000 ohm
DISPLAYED DIVISIONS	10,000d Commercial and 100,000d Non-Commercial
CAPACITIES	Programmable to 999999

1.3. Specifications, Continued

1.3.3. Standard Settings

Zero Range	, 2 % or 100%
Auto Zero Tracking	F, 0.5, 1 or 3 divisions
Balance	F, 0.5, 1 or 3 divisions
Filter	w, Animal, Standard, and Fast
Display Update Rate	, 0.4, and 0.8 seconds

1.3.4. Weight Accumulator

Capacity	999,999 Weight Units – Printed or viewed.
----------	---

1.3.5. Outputs

PORT 1	Bidirectional Serial Port. Settings include OFF , RS232 , RS422, and RS485 . RS232 has 30+ updates a second
PORT 2	Port 2 is used to interface to the PC2255 program , OR, Provide 20mA passive , RS232 , RS422 , or RS485 .

1.3.6. PC2255

<ul style="list-style-type: none"> • Computer software utility program is available for your local Fairbanks Representative. • PC2255 is required for setting certain aspects of programming, such as custom Units and custom ticket formatting.
--

1.3.7. Power Requirements

<ul style="list-style-type: none"> • 117 volts AC +/- 10 % • 220 volts AC +/- 10 % • $\leq 0/2$ volts AC between Neutral and Ground
<ul style="list-style-type: none"> • 1.5 watts maximum • The FB2255 is designed to operate from 80 to 260 volts AC, 50 to 60 Hertz

1.3. Specifications, Continued

1.3.8. DC Models

Batteries	Five (5) Size "D" Alkaline batteries @ 1.5 Volts DC each.
Battery Life	<p>Battery usage time can be adversely affected by battery storage, battery capacity and battery brand.</p> <p>To maximize battery life, serial Ports 1 and 2 should be switched OFF, if not used.</p> <p>(1) 350Ω load cell, Back Light = OFF, RS232 ports = OFF.....55 hours</p> <p>(4) 350Ω load cell, Back Light = ON, RS232 ports = OFF.....16 hours</p> <p>(4) 350Ω load cell, Back Light = OFF, RS232 ports = OFF.....33 hours</p>
Internal Battery	<ul style="list-style-type: none"> Should be replaced every 12 months using Panasonic CR 1220 3V or equivalent.

1.3.9. Out of Range Warnings

HiCAP	Scale input is over capacity
-----	Displayed weight exceeds 6 digits
Sleep Mode	Settings include OFF, 1, 2, 5, 10, 20, and 30 minutes
Time and Date	Battery Maintained

1.3.10. External Printers

Tape Printers	Citizens IDP 3550 and Epson Model TM-U220 Tape Printers
Serial Form Printers	Okidata 184 & 186 Serial Form Printer
	Okidata 420 Serial Form Printer
Ticket Printers	Epson Models TM-U295, TM-U590 Ticket Printers

1.3.11. Environment

Temperature	-10°C to + 40°C (+14°F to + 104°F)
Storage Temp.	-40°C to + 60°C (-40°F to + 140°F)

1.4. Accessories

Optional accessories include the following.

FIELDBUS DEVICES				
DeviceNet™	ControlNet™	PROFIBUS®-DP	Modbus®	Ethernet/IP

4-20MA ANALOG CURRENT LOOP OUTPUT	
<ul style="list-style-type: none"> 16 bit Resolution and Monotonicity 	<ul style="list-style-type: none"> 0.01% Non-Linearity
<ul style="list-style-type: none"> Isolated 4mA to 20mA 	<ul style="list-style-type: none"> Front Panel Programmable or via PC2255 utility software program

BLUETOOTH® TECHNOLOGY INTERFACE
<ul style="list-style-type: none"> Utilizes either Port 1 or Port 2 Serial Output. RS232 serial Interface to Bluetooth Interface. Range 100 meters (328 feet). The Bluetooth option will operate either as a Client or Server depending on which device the FB2255 is connected. <ul style="list-style-type: none"> If connected to a printer, the FB2255 will be a Server. If connected to a PC, the Instrument will be a Client.

WARNING!

Absolutely no physical, electrical or program modifications other than selection of standard options and accessories can be made by customers to this equipment

Repairs are performed by Fairbanks Scales Service Technicians and Authorized Distributor Personnel ONLY!

Failure to comply with this policy voids all implied and/or written warranties

1.5. AC Operation

The FB2255 is designed to operate from **80 to 260 volts AC, 50 to 60 Hertz** with **Auto Switching** capability.

- 110 Volt AC Operation
 - The FB2255 is factory wired for 110 VAC and requires a three-prong grounded outlet.

FB2255 TB3	FB2255 Power Cord	Connection
1	Brown/Black	AC (HOT) 117 VAC
2	Blue/White	ACC (Neutral)
3	Green/Green-Yellow	Ground

- 220 Volt AC Operation
 - Rewire the power cord according to the following diagram:

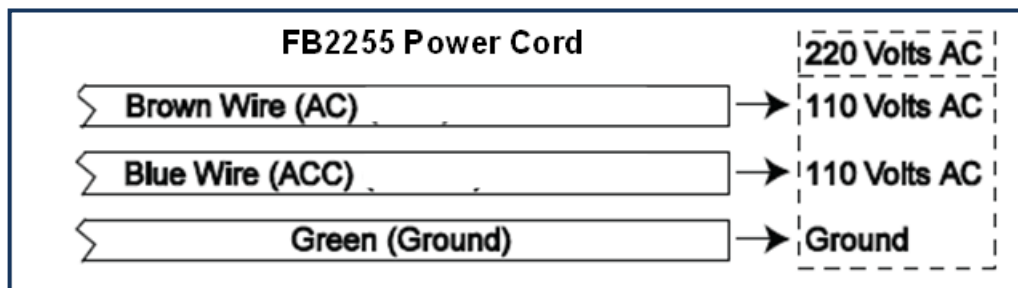

1.6. Powering up the FB2255

1. Press and hold the **ON / OFF Key** for one to two (1 – 2) seconds.
 - ✓ The Instrument will display “888888”, then a “1234567890” character display moving from right to left, followed by the revision of software.
 - ✓ Upon completing the warm-up, the FB2255 will display the actual weight on the scale.
2. Press and hold the **ON/OFF Key** for one to two (1 – 2) seconds to turn off the FB2255.

Section 2: User Operations

2.1. Front Panel Key Functions

ON/OFF	Turns the Instrument on or off.
UNITS	Switches between pre-programmed selectable weight units.
ZERO	Sets the display to zero, programmable: 2% or 100% of capacity.
B/G – NET	Toggles between Gross and Net weights <ul style="list-style-type: none">This only applies if a Tare Value has been entered greater than ZERO.
TARE	Automatically tares off displayed weight when key is pressed.
PRINT	Simple RS232 output when key is pressed.
0-9	Used for Programming and inputting manual tares.
MENU	Gains access to the sub-menus in the Configuration Mode .
Arrow Keys	Used for scrolling through the menu selections.

Depending on programmed selection, **Tare Weight** amount will do one of the following.

- ✓ Be retained for reuse until changed, or if power is removed.

OR...

- ✓ Automatically clear when **Gross Weight** returns to **ZERO**.



2.2. Front Panel Programming Parameters

Follow these steps to program the Instrument.

2.2.1. Setting and Programming the Time

1. Press and hold the **PRINT** key for 3 seconds; **Set-ti** displays, followed by the current time setting in **HHMMSS** format.
2. Press the **MENU** key to edit or **RIGHT ARROW KEY** to skip.
 - The first digit will blink.
 - Key the new time setting with the **0-9** keys.
3. When complete, the program will advance to the current display format setting.
 - **12hr A** – 12 hour clock, currently AM.
 - **12hr P** – 12 hour clock, currently PM.
 - **24 hour** – Military time (1:00 PM = 1300 hours).
4. Press the **MENU** key to edit, or **RIGHT ARROW KEY** to skip.
 - Use the **ARROW KEYS** to toggle through the options.
 - Press **ENTER** to save the setting.
5. When complete, the program will advance to Programming the Date.

2.2.2. Programming the Date

1. **Set-dA** displays, followed by the current date setting in **MM-DD-YY** format.
2. Press the **MENU** key to edit or **RIGHT ARROW KEY** to skip.
 - The first digit will blink.
 - Key the new date setting with the **0-9** keys.
3. When complete, instrument will return to weigh mode.

NOTE: See [Section 3.2: TB4 Wiring connections](#) and [Section 4: INPUT/OUTPUT](#) for information on configuring Port 1 and Port 2 parameters.

2.2.3. Checking Power Supply / Battery Voltage

1. Press the **TARE** key for **three (3) seconds**.
 - The battery current or power supply voltage displays
 - 8.3 VDC nominal.

2.2.4. Programming the Sleep Function

1. Press and hold the **BG/Net** key for three (3) seconds.
 - The display will indicate **SLEEP**, and then display the current setting.
 - This function serves to prolong battery life by turning off the Instrument.
 - When there is no activity, the **Sleep Mode** activates according to the programmed time frame.
 - Activity is when weight is applied to the scale exceeding the balance setting, pressing a key, and receiving a polling request on a communication port.
2. Press **MENU**.
3. Use the **Arrow Keys** to toggle between the available options.
 - Selections in minutes include **OFF, 1, 2, 5, 10, 20, 30**.
4. Press **ENTER** to save the setting.

2.3. Operating Procedures

1. Press and hold the **ON / OFF** Key for two (2) seconds.
 - ✓ The Instrument will display “**888888**”, followed by “**1234567890**” character display moving from right-to-left, then the revision of software.
 - ✓ Once the warm-up is complete, the FB2255 displays the actual weight on the scale.
2. To turn the **FB2255** off, press the **ON / OFF** key for two (2) seconds
 - ✓ The **Zero. Tare** and the **AZT** functions require the displayed weight to be stable before these functions will operate.
 - ✓ The weight reading is stable if the variation in weight is less than the programmed **BAL RANGE**.

2.3.1. Programming Port 1

1. **Port 1** displays, followed by the current protocol setting.
 - **OFF** – com port is not active.
 - **rS232** – using RS232 protocol
 - **rS485** – using RS485 or RS422 protocol
2. Press **MENU** key to edit, or **RIGHT ARROW KEY** to skip.
 - Press the **RIGHT ARROW** key to scroll through available settings.
 - Press **ENTER** to select an option.
3. When complete, the program will advance to output.

2.3.2. Programming the Port 1 Output Type

1. Output displays, followed by the current output type setting:
 - **Button** -Using the Print key.
 - **Auto**- Activated by stable weight above 10d, reset by return to half of printed weight.
 - **Contin** -Continuous Output. Once every display update rate.
 - **Poll** -Demand Output by receipt of CR or programmed poll character
 - **Rd2200** -Remote Display for FB2200
 - **Rd2250** -Remote Display for FB2250/55
 - **Rd2300** -Remote Display for 2300
 - **Rd2500** -Remote Display for 2500
 - **Rd2800** -Remote Display for 2800
 - **Rd5200** -Remote Display for 5200
 - **P Ship** -Used for FedEx Shipping Software
 - **UPS** -Used for UPS Shipping Software
 - **OFF** -Output is not active
2. Press **MENU** key to edit, or **RIGHT ARROW KEY** to skip.
 - Press the **RIGHT ARROW KEY** to scroll through available settings.
 - Press **ENTER** to select an option.
3. When complete, the program will advance to Port 1 Baud Rate.

2.3.3. Programming Port 1 Baud Rate

1. **Baud 1** displays, followed by the current baud rate setting.



- 2400
- 4800
- 9600
- 19200
- 38400
- 57600
- 115200

2. Press **MENU** key to edit, or **RIGHT ARROW KEY** to skip.
 - Press the **RIGHT ARROW KEY** to scroll through available settings.
 - Press **ENTER** to select an option.
3. When complete, the program will advance to Port 1 Data Bits.

2.3.4. Programming Port 1 Data Bits

1. **d-bitS** displays, followed by the current data bits setting:
 - 8
 - 7
2. Press **MENU** key to edit, or **RIGHT ARROW KEY** to skip.
 - Press the **RIGHT ARROW KEY** to scroll through available settings.
 - Press **ENTER** to select an option.
3. When complete, the program will advance to Port 1 Parity Setting.

2.3.5. Programming Port 1 Parity Setting

1. **Parity** displays, followed by the current parity bit setting:
 - **P None** – no parity bit
 - **P Odd** - odd parity bit
 - **P Even** – even parity bit
2. Press **MENU** key to edit, or **RIGHT ARROW KEY** to skip.
 - Press the **RIGHT ARROW KEY** to scroll through available settings.
 - Press **ENTER** to select an option.
3. When complete, the program will advance to Port 1 stop bits.

2.3.6. Programming Port 1 Stop Bits

1. **Stop** displays, followed by the current stop bits setting:
 - 1

- 2
- 2. Press **MENU** key to edit, or **RIGHT ARROW KEY** to skip.
 - Press the **RIGHT ARROW KEY** to scroll through available settings.
 - Press **ENTER** to select an option.
- 3. When complete, the program will advance to Port 2.

2.3.7. Programming Port 2

1. **Port 2** displays, followed by the current protocol setting:
 - **OFF** - com port is not active
 - **rS232** - Using RS232 protocol
 - **rS485** - Using RS485 or RS422 protocol
 - **Cloop** Using 20mA Current Loop (passive)
2. Press **MENU** key to edit, or **RIGHT ARROW KEY** to skip.
 - Press the **RIGHT ARROW KEY** to scroll through available settings.
 - Press **ENTER** to select an option.
3. When complete, the program will advance to Port 2 Output.

2.3.8. Programming the Port 2 Output Type

1. **Output** displays, followed by the current output type setting:
 - **Auto** - Activated by stable weight above 10d, reset by return to half of printed weight.
 - **Contin** - Continuous Output. Once every display update rate.
 - **Poll** - Demand Output by receipt of CR from external source.
 - **r Disp** - 1600 Series Remote Display output format
 - **P Ship** - Used for FedEx Shipping Software
 - **UPS** - Used for UPS Shipping Software
 - **OFF** - output is not active.
2. Press **MENU** key to edit, or **RIGHT ARROW KEY** to skip.
 - Press the **RIGHT ARROW KEY** to scroll through available settings.
 - Press **ENTER** to select an option.
3. When complete, the program will advance to Port 2 baud rate.

2.3.9. Programming Port 2 Baud Rate

1. **Baud 2** displays, followed by the current baud rate setting.

- 2400
- 4800
- 9600
- 19200
- 38400
- 57600
- 115200

2. Press **MENU** key to edit, or **RIGHT ARROW KEY** to skip.
 - Press the **RIGHT ARROW KEY** to scroll through available settings.
 - Press **ENTER** to select an option.
3. When complete, the program will advance to Port 2 Data Bits.

2.3.10. Programming Port 2 Data Bits

1. **d-bitS** displays, followed by the current data bits setting:
 - 8
 - 7
2. Press **MENU** key to edit, or **RIGHT ARROW KEY** to skip.
 - Press the **RIGHT ARROW KEY** to scroll through available settings.
 - Press **ENTER** to select an option.
3. When complete, the program will advance to Port 2 Parity Setting.

2.3.11. Programming Port 2 Parity Setting

1. **Parity** displays, followed by the current parity bit setting:
 - **P None** – no parity bit
 - **P Odd** - odd parity bit
 - **P Even** – even parity bit
2. Press **MENU** key to edit, or **RIGHT ARROW KEY** to skip.
 - Press the **RIGHT ARROW KEY** to scroll through available settings.
 - Press **ENTER** to select an option.
3. When complete, the program will advance to Port 2 stop bits.

2.3.13. Programming Port 2 Stop Bits

1. **Stop** displays, followed by the current stop bits setting:



- 1
- 2
- 2. Press **MENU** key to edit, or **RIGHT ARROW KEY** to skip.
 - Press the **RIGHT ARROW KEY** to scroll through available settings.
 - Press **ENTER** to select an option.
- 3. When complete, the program will advance to Back light options.

2.3.14. Programming the Back Light Options

1. The current setting displays:
 - **bL On** - Back light always **ON**.
 - **bL POS** - Back light only on with a positive weight on the scale, otherwise off.
 - **bL tr1** - Back light **ON** with a positive weight on the scale until weight has been stable for the amount of time selected at the following program step.
 - **bL tr2** - Back light **ON** with a positive weight until returned to zero and stable for time selected at the following program step.
 - **bL OFF** - Back light always **OFF**.
2. Press **MENU** key to edit, or **RIGHT ARROW KEY** to skip.
 - Press the **RIGHT ARROW KEY** to scroll through available settings.
 - Press **ENTER** to select an option.
3. When complete, the program will advance to Back light timing.

2.3.15. Programming the Back Light Timing

1. The current setting displays:
 - **bLt 15** - back light remains illuminated 15 seconds
 - **bLt 30** - back light remains illuminated 30 seconds
 - **bLt 60** - back light remains illuminated 60 seconds
 - **bLt 300** - back light remains illuminated 300 seconds
2. Press **MENU** key to edit, or **RIGHT ARROW KEY** to skip.
 - Press the **RIGHT ARROW KEY** to scroll through available settings.
 - Press **ENTER** to select an option.
3. When complete, the program will advance to Configuration Menu.

2.4. Gross, Tare and Net Weight

There are three terms used when weighing an object's or load's amount.

The **NET WEIGHT** (*product only*) is the **GROSS WEIGHT** (*total amount*) minus the **TARE WEIGHT** (*container only*).

$$\text{NET WEIGHT} = \text{Gross Weight} - \text{Tare Weight}$$

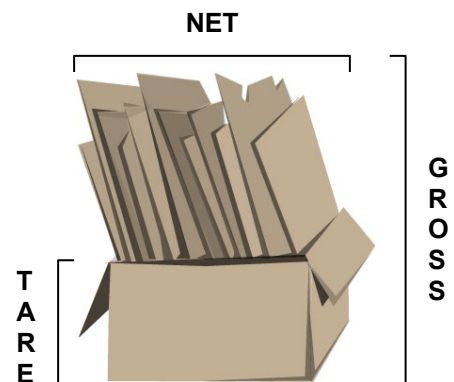

WORKING EXAMPLE

A full can of house paint is an object to be weighed. The empty can is the **TARE** weight. The paint is the **NET** weight. Together they equal the **GROSS** weight.

2.5. Basic Weighing

Follow these steps for **Basic Weighing**.

1. Empty the platform.
2. Turn the scale **ON**.
3. Press **ZERO**.
 - ✓ When the display indicates "0", it is ready for use.

2.6. Gross Weighing

Follow these steps for Gross Weighing.

1. Unload the Scale.
2. Press the **ZERO** key, if required, to set scale to “0”.
3. Place container/object on scale.
4. Read the **Gross Weight** on the display.

2.7. Net Weighing

Follow these steps for Net Weighing.

1. Unload the Scale.
2. Press the **ZERO** key, if required, to set scale to “0”.
3. Place container/object on scale (Tare weight).
4. Press the **TARE** key.
5. Place material in container or add objects (Net weight).
6. Read the **Net Weight** on the display. The caret (v) above the printed NET legend of the display will be seen.
7. To Exit; unload the scale and press the **TARE** key.

2.8. Gross/Tare/Net Weighing

1. Unload the Scale.
2. Press the **ZERO** key, if required, to set scale to “0”.
3. Place container/object on scale.
4. Press **TARE** key.
5. Place material in container or add objects.
6. Note the Net Weight on the display. The caret (v) above the printed NET legend of the display will be seen.
7. Press the **GROSS/NET** key to switch to read the Gross Weight on the display.
8. Press the **GROSS/NET** key to toggle back and forth between **Gross & Net** weight.
9. To Exit; unload the scale and press the **TARE** key.

2.9. Weight Accumulation

Note: For the following operations to function:

- The Accumulator parameter “ACC” must be set to “Y”
 - When using the PC2255 utility program, Operating Mode must be set to “*Accumulation*”
-

2.9.1 Weight Accumulation

1. Unload the Scale.
2. Press the **ZERO** key, if required, to set scale to “0”.
3. (optional) If the weighment is going to require a Tare, place the object or container on the scale and press the **TARE** key.
4. Place material on the scale.
5. When the weight is stable, press the **B/G NET** key. The display alternates between the number of Accumulations “n” and the total weight Accumulated, either NET or Gross.
 - The caret will appear above *Total Weight Accumulated*. A caret will also appear above NET if a tare was entered.
6. Press the **UNITS** key to accept the weight, display will momentarily indicate “**ACCEPT**”, and return to the weigh screen.

OR

Press the **B/G NET** key to skip and return to the weigh screen.

7. The scale must return to “0” **Gross Mode** before another accumulation can occur.
8. Repeat steps 3 through 7 for additional accumulations, up to 99,999 accumulations, or 999,999 totaled weight units.

NOTE: Gross and Net accumulations are stored and reported separately in the 2255, and the status of each weighment is determined by whether a Tare was initially entered.

2.9.2 Printing Weight Accumulations

1. Ticket formats can be edited through the PC225X web utility through COM 2 of the instrument.
2. If the desired print is a continuous output of the accumulating weights, the standard GNT ticket format can be used for a given printer. Autoprint can be



used with this format, or the PRINT key can be pressed during each weighing. The ticket examples below demonstrate this format.

```
10:33AM  
12-04-19  
11 1b GR  
  
10:33AM  
12-04-19  
12 1b GR  
  
10:33AM  
12-04-19  
13 1b GR  
  
10:33AM  
12-04-19  
17 1b GR
```

```
10:36AM  
12-04-19  
22 1b GR  
6 1b TA  
16 1b NT  
  
10:37AM  
12-04-19  
19 1b GR  
6 1b TA  
13 1b NT  
  
10:37AM  
12-04-19  
13 1b GR  
3 1b TA  
10 1b NT
```

3. If it is necessary to print a Total Accumulation on the ticket, the following settings can be activated in the ticket format section of the web utility, based on the desired printout:



- CNT GR: The number of Gross accumulations stored in the instrument.
- CNT NT: The number of Net accumulations stored in the instrument.
- GR Acc: The total accumulated gross weight.
- NT Acc: The total accumulated net weight.

NOTE: Autoprint is not compatible with printing accumulated totals.

4. If a running total is required with a GNT ticket for each weighment, enable either **CNT GR** and **GR ACC** or **CNT NT** and **NT ACC**, depending on the type of weighment.
5. After completing *Step 6* of the weight accumulation procedure, press the **PRINT** key before removing objects from the scale. The full GNT ticket will print with the accumulated totals.

```
09:43AM
12-04-19
      80 lb GR

1 Items GR
      80 lb GR Total

09:44AM
12-04-19
      125 lb GR

2 Items GR
      205 lb GR Total

09:44AM
12-04-19
      95 lb GR

3 Items GR
      299 lb GR Total
```

```
10:28AM
12-04-19
      102 lb GR
       16 lb TA
       86 lb NT

1 Items NT
       86 lb NT Total

10:29AM
12-04-19
      103 lb GR
       12 lb TA
       91 lb NT

2 Items NT
      177 lb NT Total

10:30AM
12-04-19
      116 lb GR
       13 lb TA
      103 lb NT

3 Items NT
      281 lb NT Total
```

6. To print total accumulation only, deactivate the **Time**, **Date**, **Gross**, **Tare**, and **Net** fields in the web utility.
7. Press the **PRINT** key to print accumulated totals after completing the accumulation.

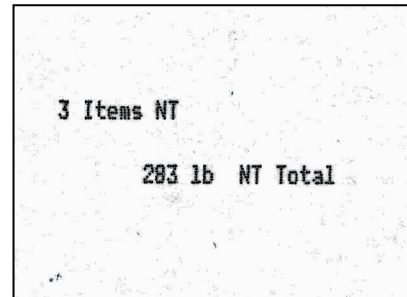
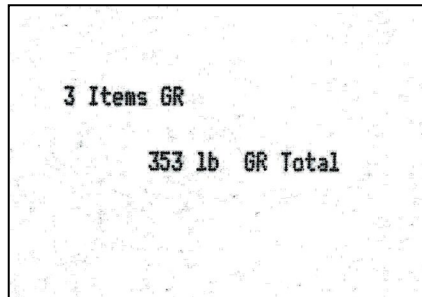

2.10. Number of Accumulations

1. Press and hold the **ZERO** key for three (3) seconds.
 - The display will alternate between the number of Gross weight Accumulations "**n**" and the total Gross weight Accumulated for thirty (30) seconds, then return to the **Weigh Mode**.
 - The caret (v) above the printed Total Weight Accumulated legend of the display will be seen.
2. Press the **B/G NET** key
 - The display will alternate between the number of Net weight Accumulations "**n**" and the total Net weight Accumulated for thirty (30) seconds, then return to the **Weigh Mode**.
 - The caret (v) above the printed Total Weight Accumulated and NET legends of the display will be seen.
3. Press the **B/G NET** key to alternate between Gross and Net accumulations or press the **UNITS** key at any time to exit immediately to the **Weigh Mode**.

2.11. Clearing the Accumulators

The Accumulator(s) to be cleared depend on whether the **Operating Mode** is programmed to **Accumulation**, **Peak Weight**, or **Piece Count and Total**.

- Press and hold the **BG/NET** key for three (3) seconds.
- **SLP.OFF** is displayed, press the right arrow key.
- **CLr.Acc** is displayed, press the MENU key,
- **CLr.YES** is displayed, press the left or right arrow keys to toggle between **Yes** or **No**.



- **Clr.YES** (Clear the Accumulator)
- **CLr.NO** (Do NOT Clear the Accumulator)
- Press the **ENTER** key to enter the selection.
- When complete, the FB2255 will return to the weight mode.

2.12. Piece Counting

Note: For the following operation to function:

- The Piece Count parameter “PCt”, the Accumulator parameter “ACC”, and the Peak Hold parameter “P-Hold” must be configured during initial installation.
 - When using PC2255 utility program, Operating Mode must be set to “*Piece Count*” (See [Section 6.5.](#)).
-

1. Unload the Scale.
2. Press the **ZERO** key, if required, to set scale to “0”.
3. Place the empty weighing container on the Scale Platform.
4. Press the **TARE** key.
 - ✓ This stores the container weight only, placing the scale in the **Net Mode**.
 - ✓ “0” should display on the instrument and the caret (v) above the printed NET legend of the display will be seen.
5. Press the **B/G NET** key.
 - ✓ The Display prompts to “Add 1” number of sample parts to the container.
6. Pressing the **B/G NET** key repeatedly will prompt the user to;
“Add 1”, “Add 5”, “Add 10”, “Add 25”, “Add 50”, or “Add 100” sample pieces.
7. Add the required sample pieces to the container, then press the **UNITS** key.
 - ✓ The Display will alternate between indicating the net weight and the number of sample pieces.
8. Continue to add the remaining pieces to the container.
 - ✓ The display will update and continue to alternate between the net **Weight** and **Number of Pieces**, including the original sample.
9. To Exit to the NET Weigh Mode, press the **B/G NET** key.
 - ✓ When in the NET Weigh Mode, if the **ZERO** key is held for 3 seconds, the number of pieces on the scale (with container) at the time the key is pressed will be displayed for 30 seconds, or until the **UNITS** key is pressed.

2.13. Piece Count and Total

Note: For the following operation to function:

- The Piece Count parameter “Pct”, the Accumulator parameter “ACC”, and the Peak Hold parameter “P-Hold” must be configured during initial installation.
- When using PC2255 utility program, Operating Mode must be set to “*Piece Count and Total*” (See Section 6.5).

This feature enables the FB2255 to display the Count and **Net Weight** of the counted items, and to display the Total Count of accumulated items.

1. Unload the Scale.
2. Press the **ZERO** key, if required, to set scale to “0”.
3. Place the empty weighing container on the Scale Platform.
4. Press the **TARE** key.
 - ✓ This stores the container weight only, placing the scale in the **Net Mode**.
 - ✓ “0” should display on the instrument and the caret (v) above the printed NET legend of the display will be seen.
5. Press the **B/G NET** key.
 - ✓ The Display prompts to “**Add 1**” number of sample parts to the container.
6. Pressing the **B/G NET** key repeatedly will prompt the user to;
“**Add 1**”, “**Add 5**”, “**Add 10**”, “**Add 25**”, “**Add 50**”, or “**Add 100**” sample pieces.
7. Add the required sample to the container, then press the **UNITS** key.
 - ✓ The Display alternates between indicating the net weight and the number of sample pieces.
8. Continue to add the remaining pieces to the container.
 - ✓ The display will update and continue to alternate between the net **Weight** and **Number of Pieces**, including the original sample.
9. Press the **B/G NET** key.
 - ✓ The Display will alternate between the “**Total**” legend and the total **Number of Pieces Accumulated** plus the current **number of pieces**.
 - ✓ Press the **B/G NET** key to return to step 6.
10. Press the **UNITS** key to save the new Total in the accumulator and return to the **NET Weigh Mode**.
 - ✓ To continue adding to the Total, repeat steps 1-10.
 - ✓ To reset the Total see “Clearing the Accumulators” (Section 2.11)

- ✓ When in the NET Weigh Mode, if the **ZERO** key is held for 3 seconds, the number of pieces on the scale (with container) at the time the key is pressed will be displayed for 30 seconds, or until the **UNITS** key is pressed.

2.14. Peak Weight

Note: For the following operation to function:

- Peak Hold parameter “P-Hold”, the Piece Count parameter “Pct”, and the Accumulator parameter “ACC” must be configured during initial installation.
 - When using PC2255 utility program, Operating Mode must be set to “*PEAK HOLD STABLE*” or “*PEAK HOLD UNSTABLE*.” (See [Section 6.5.](#))
-

The **Peak Weight** feature records the heaviest stable or unstable load placed on the scale, and the time and date it occurred. To display the current Peak Weight perform the following:

1. Press and hold the **ZERO** key for three (3) seconds.
 - The display will show the **time** and then alternate between the **date** and **Peak Weight Value**, for thirty (30) seconds, then return to the **Weigh Mode**.
2. Press the **UNITS** key to end the process and immediately exit to the **Weigh Mode**.
 - To reset the Peak Weight value see “Clearing the Accumulators” ([Section 2.11.](#)).

2.15. Monorail

The Monorail feature provides the ability to manually Tare values that are smaller than the standard division size. This allows the user to Tare off smaller items, such as: trolley hook, banding materials, ect.

NOTE:

- Pounds and kilograms are the only available units of measure.
 - This setting is designed for a 1000 lb capacity and a 0.5 lb division size scale.
 - Auto Tare is disabled in this mode. All Tare values must be manually entered.
 - Manual Tare values of 0.1 lb and 0.2 lbs (pound mode); and 0.1 kg (kilogram mode) will not be accepted. Values must be greater than 50% of standard division size.
-

Section 3: Serial Communication Wiring

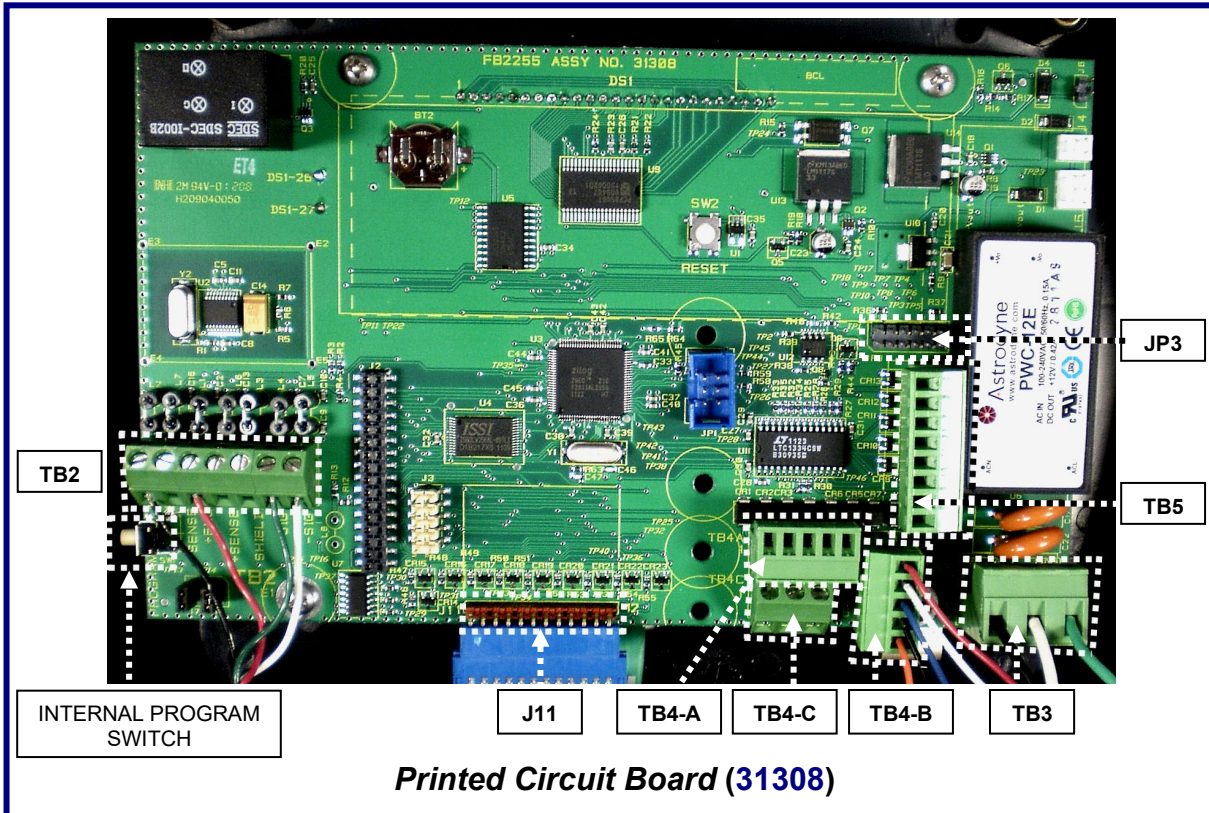

3.1. JP3 Jumper Configuration

JP3	RS232	RS485	RS422*	PORT
1-2	Out	120 Ohm Resistor	120 Ohm Resistor	COM1
3-4	Out	In	Out	COM1
5-6	Out	In	Out	COM1
7-8	Out	In	Out	COM2
9-10	Out	In	Out	COM2
11-12	Out	120 Ohm Resistor	120 Ohm Resistor	COM2

*Port should be set to RS485.

NOTE: 120 ohm Termination Resistors are required if the receiver is the last node on the network.

3.2. TB4 Wiring connections, COM1 (A), COM2 (B), and COM2 (C)

TB4 (A)	RS232		RS485	RS422*	PORT
1	Rx – Receive Data		(-) RS485	RS422 (-) Rx	COM1
2	Tx – Transmit Data		(-) RS485	RS422 (-) Tx	COM1
3	CTS – Clear-to-Send		(+) RS485	RS422 (+) RX	COM1
4	GND -- Ground		GND	GND	COM1
5	RTS – Ready-to-Send		(+) RS485	RS422 (+) Tx	COM1

TB4 (B)	RS232	DB9 ABS ONLY	RS485	RS422*	PORT
1	Rx – Receive Data	2	(-) RS485	RS422 (-) Rx	COM2
2	TX – Transmit Data	3	(-) RS485	RS422 (-) Tx	COM2
3	CTS – Clear-to-Send	8	(+) RS485	RS422 (+) Rx	COM2
4	GND – Ground	5	GND	GND	COM2
5	RTS – Ready-to-Send	7	RS485	RS422 (+) Tx	COM2

TB4 (C)	20MA		RS485	RS422	PORT
1	(+) TX – Remote Display Passive, 20mA Output				COM2
2	(-) TX – Remote Display Passive, 20mA Output				COM2
3		(+) 7.5V Bluetooth® Technology Supply			

*Port should be set to RS485.

3.3. TB5 Remote Switch Inputs

1	Ground	
2	Ground	
3	Ground	
4	Print	Connect to ground to perform programmed Print function
5	Tare	Connect to ground to Tare off Gross weight
6	B/G Net	Connect to ground to Select Gross/Tare displays
7	Zero	Connect to ground to Zero Platform Weight
8	Units	Connect to ground to change to alternate weight units



3.4. Remote Display Active Keys

INSTRUMENT	FB2255 ACTIVE FRONT PANEL KEYS
FB2200	No Active Keys
FB2255	Units, Zero, Gross Net, Auto Tare, Print *
FB2255	Units, Zero, Gross Net, Auto Tare, Print *
2300	No Active Keys
2500/FB2550	No Active Keys
2800	No Active Keys
5200A	Units, Gross Net

* The “master” FB225X must have the printer on COM 1 and COM 1 must be configured for **Button**. COM 2 of the “master FB225X must be configured for **Poll** and the FB225X acting as the remote display must be connected to COM 2 of the “master”.

Section 4: Input / Output

4.1. 3550 Tape Printer

Transmission	RS232
Baud Rate	9600
Data Bits	8
Stop Bit	1
OUTPUT	"BUTTON" for Print Key

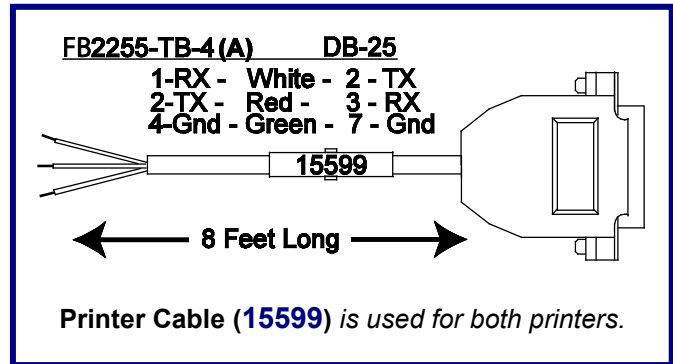
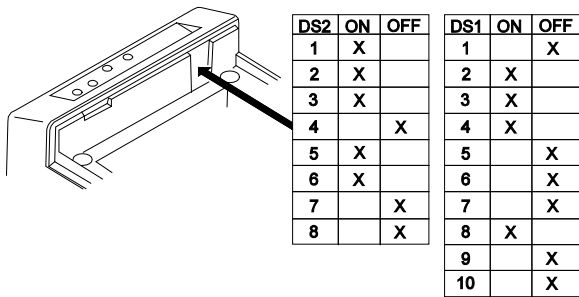

4.2. TM-U220 Tape Printer

✓ This is the TM-U220 Tape Printer (non-DAT, white case).

Transmission	RS232
Baud Rate	9600
Data Bits	8
Stop Bit	1
OUTPUT	"BUTTON" for Print Key

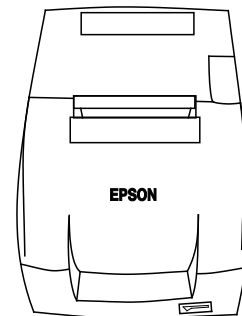

Bottom of TM-U220 Tape Printer

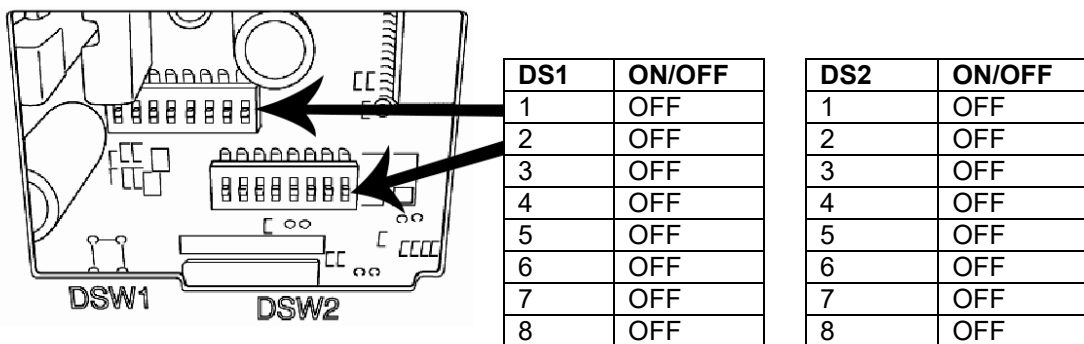

4.3. Okidata 186 T Form Printer

Transmission	RS232
Baud Rate	9600
Data Bits	8
Stop Bit	1
OUTPUT	“BUTTON” for Print Key

Switch 7 (SW2)	DTR Signal
** Space after power on	ON
Space when printer is selected	OFF
Switch 8 (SW2)	Not Used

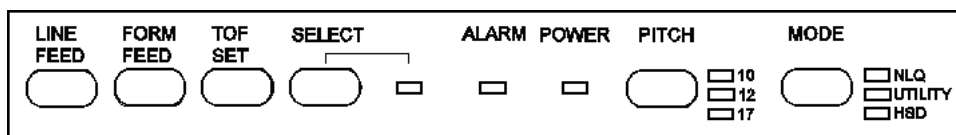

Follow these steps to change **Menu Settings**.

- To enter MENU MODE, press and hold **SELECT** while turning on the printer.
 - ✓ The “12” and “UTILITY” LEDs will blink.
- With the printer in the **Menu Mode**, press **SELECT** to print the complete menu.
 - ✓ The current default settings print out.
 - ✓ It is recommended to use tractor fed paper.

NOTE: *The Printed Menu selections are different for each Emulation Mode.*

- Press **LINE FEED** to select the relevant group to be changed.
 - ✓ The group is the left-hand column on the **Menu Printout**.
- Press **FORM FEED** to select the relevant item within the selected group.
 - ✓ The Item is the center column on the **Menu Printout**.
- Press **TOF SET** to cycle through the settings available for the item to change.

4.3. Okidata 186 Form Printer, Continued

- ✓ The settings are the right-hand column on the **Menu Printout**.
6. To continue making changes: press **LINE FEED** for the next group or press **FORM FEED** for the next item.
 - ✓ Repeat as needed until finished changing settings.
 7. Press **PITCH** and **MODE** together to save the changes and exit the **Menu Mode**.

NOTES: *Exiting the **Menu Mode** by turning off the printer will cancel any changed settings.*

- ✓ Printed menu's changes according to the **Printer Emulation Mode**.
- ✓ If printer emulation mode is not set to **ML**, set this first, then reprint the menu.

GROUP (Press LINE FEED to change)	ITEM (Press FORM FEED to change)	SET (Press TOF SET to change)
Printer Control	Emulation Mode	ML
Font	Print Mode	Utility
Font	DRAFT Mode	SSD
Font	Pitch	10 CPI
Font	Proportional Spacing	No
Font	Style	Normal
Font	Size	Single
Symbol Sets	Character Set	Standard
Symbol Sets	Language Set	American
Symbol Sets	Zero Character	Slashed
Symbol Sets	Code Page	USA
Vertical Control	Line Spacing	6 LPI
Vertical Control	Skip Over Perforation	No
Vertical Control	Page Length	11"
Set-Up	Graphics	Bi-directional
Set-Up	7 or 8 Bits Graphics	7
Set-Up	Receive Buffer Size	128K
Set-Up	Paper Out Override	No
Set-Up	Paper Registration	0
Set-Up	7 or 8 Bits Data Word	8

4.3. Okidata 186 Form Printer, Continued

Set-Up	Operator Panel Function	Full Operation
Set-Up	Reset Inhibit	No
Set-Up	Print Suppress Effective	Yes
Set-Up	Auto LF	No
Set-Up	Print DEL Code	Yes
Set-Up	Time Out Print	Invalid
Set-Up	Auto Select	No
Set-Up	Impact Mode	Normal

GROUP	ITEM	SET
Parallel I/F	I-Prime	Buffer Print
Parallel I/F	Pin 18	+5v
Parallel I/F	Bi-Direction	Enable

Serial PCB Assy Switch Settings: (SW1) (** indicates typical Fairbanks setting)

Parity Type	Switch 1 (SW1)
** Odd parity	ON
Even parity	OFF

Parity	Switch 2 (SW1)
** No parity	ON
With parity	OFF
Data Bits	Switch 3 (SW1)
** 8 Bits	ON
7 Bits	OFF

Protocol	Switch 4 (SW1)
Ready/Busy	ON
** X-ON, X-OFF	OFF

Test Select	Switch 5 (SW1)
** Circuit	ON
Monitor	OFF
Mode Select	Switch 6 (SW1)
** Print mode	ON
Test mode	OFF

4.4. Okidata 420 Form Printer

Program the FB2255 the following settings.

Transmission	RS232
Baud Rate	9600
Data Bits	8
Stop Bit	1
OUTPUT	"BUTTON" for Print Key

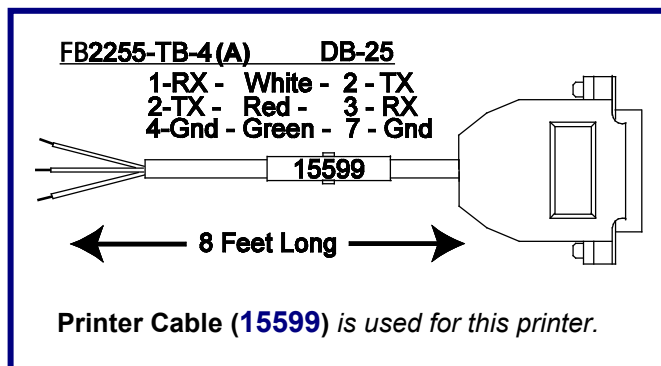

NOTE: Always restart the printer after making any switch changes.

SEL						
SEL		LF	FF/LOAD	TEAR	PARK	QUIET
MENU	SHIFT	Micro Feed Down	Micro Feed Up			TOF
EXIT		GROUP	ITEM	SET	PRINT	
POWER	ALARM		MENU			

- To enter **MENU MODE**, press and hold the **SHIFT** key while pressing the **SELECT** key.
 - ✓ The **MENU** legend will be illuminated while in the Menu Mode.
- With the printer in the **Menu Mode**, press **PRINT** to print the complete menu.
 - ✓ The current default settings print out.
 - ✓ It is recommended to use tractor fed paper.

NOTE: The Printed Menu selections are different for each Emulation Mode.

- Press **GROUP** to select the relevant group that needs to be changed.
 - ✓ Found on the left-hand column on the **Menu Printout**.
- Press **ITEM** to select the relevant item within the selected group.
 - ✓ Found on the Item is the center column on the **Menu Printout**.
- Press **SET** to cycle through the settings available for the item to change.
 - ✓ The settings are the right-hand column on the **Menu Printout**.
- Press and hold the **SHIFT** key while pressing the **SELECT** key to exit the **Menu Mode**.

4.4. Okidata 420 Form Printer, Continued

NOTE: *If the printer is turned off before exiting the **MENU MODE**, all changes will be lost.*

GROUP (Press LINE FEED to change)	ITEM (Press FORM FEED to change)	SET (Press TOF SET to change)
Printer Control	Emulation Mode	IBM PPR
Font	Print Mode	Utility
Font	DRAFT Mode	HSD
Font	Pitch	10 CPI
Font	Proportional Spacing	No
Font	Style	Normal
Font	Size	Single
Symbol Sets	Character Set	Set 1
Symbol Sets	Language Set	American
Symbol Sets	Zero Character	Slashed
Symbol Sets	Code Page	USA
Rear Feed	Line Spacing	6 LPI
Rear Feed	Form Tear-off	Off
Rear Feed	Skip Over Perforation	No
Rear Feed	Page Length	11"
Bottom Feed	Line Spacing	6 LPI
Bottom Feed	Form Tear-off	Off
Bottom Feed	Skip Over Perforation	No
Bottom Feed	Page Length	11"
Top Feed	Line Spacing	6 LPI
Top Feed	Form Tear-off	Off
Top Feed	Skip Over Perforation	No
Top Feed	Page Length	11"

4.4. Okidata 420 Form Printer, Continued

GROUP	ITEM	SET
Set-Up	Graphics	Uni-directional
Set-Up	Receive Buffer Size	64K
Set-Up	Paper Out Override	No
Set-Up	Print Registration	0
Set-Up	Operator Panel Function	Full Operation
Set-Up	Reset Inhibit	No
Set-Up	Print Suppress Effective	Yes
Set-Up	Auto LF	No
Set-Up	Auto Select	No
Set-Up	SI Select Pitch (10CP)	17.1 CPI
Set-Up	SI Select Pitch (12CPI)	12 CPI
Set-Up	Time Out Print	valid
Set-Up	Auto Select	No
Set-Up	Centering Position	DEFAULT
Set-Up	ESC SI Pitch	17.1 CPI
Set-Up	Power Saving	Enable
Set-Up	Power Save Time	5 Min
Parallel I/F	I-Prime	Buffer Print
Parallel I/F	Pin 18	+5v
Parallel I/F	Bi-Direction	Enable
Serial I/F	Parity	None
Serial I/F	Serial Data 7/8 Bits	8 Bits
Serial I/F	Protocol	X-On/X-Off
Serial I/F	Diagnostic Test	No
Serial I/F	Busy Line	SSD-
Serial I/F	Baud Rate	9600 BPS
Serial I/F	DSR Signal	Invalid
Serial I/F	DTR Signal	Ready on Pwr up
Serial I/F	Busy Time	200 ms

4.5. TM-U295 Ticket Printer

Transmission	RS232
Baud Rate	9600
Data Bits	8
Stop Bit	1
OUTPUT	"BUTTON" for Print Key

Set the dip switches to the following.

- 1 and 3 are **ON**.
- The rest are **OFF**.

NOTE: Always restart the printer after making any switch changes.

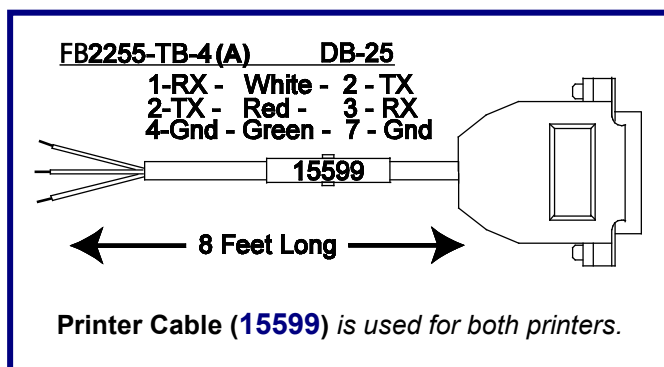

4.6. TM-U590 Ticket Printer

Transmission	RS232
Baud Rate	9600
Data Bits	8
Stop Bit	1
OUTPUT	"BUTTON" for Print Key

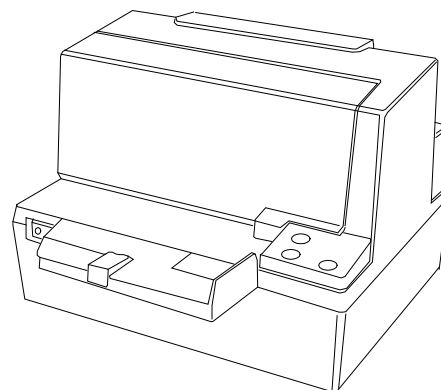

Set the dip switches to the following.

- DSW 1
- DSW 2
- 1, 3 and 7 are **ON** only.
- All are **OFF**.

4.7. Remote Display

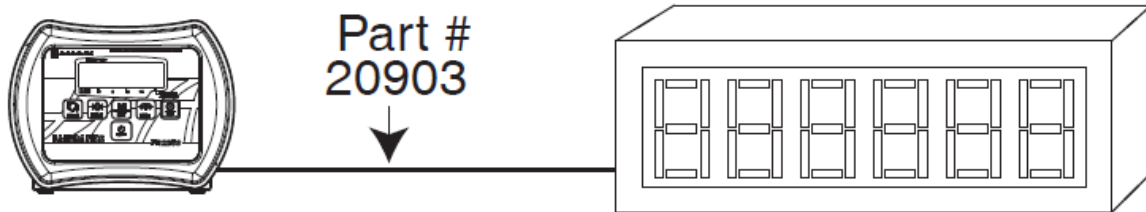

Using the **20mA Serial Current Loop Output** will allow transmission distances up to **1000 cable feet**.

✓ **Interface Cable (20903)** is recommended.

	Port 2
Protocol	C-Loop
Baud Rate	9600
Data Bits	8
Parity	None
Stop Bit	1
Output Type	rDisp

The 1600 Series remote display must be wired for **20mA Active**, and programmed to match the FB2255.

– Wiring to the FB2255: **TB4 (C)** to the **Remote Display** (see section 4.6).

1	Tx + Passive 20mA Output
2	Tx – Passive 20mA Output

Wire the 1600/1500 Series **Remote Display** to the FB2255 as shown in this diagram.

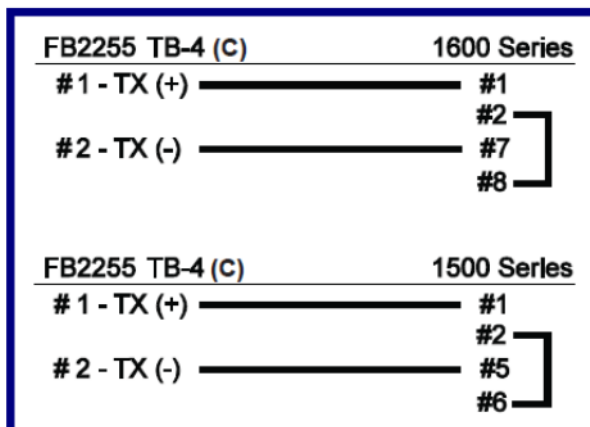

4.8. 4-20mA Analog Output Setup

WARNING: Do not physically install the 4-20mA card until the instrument is configured and calibrated (weight) to the platform.

Access to this feature is conditional, and depends upon whether it is enabled in the **FB2255 Internal Programming**.

The 4-20mA analog output is passive, so therefore it requires the receiving element to supply the loop with a dedicated, isolated power source from 7-24V DC. The output is linear throughout the range from 4mA to 20mA, and can be programmed to increase (upweigh) or decrease (downweigh) as weight is increased.

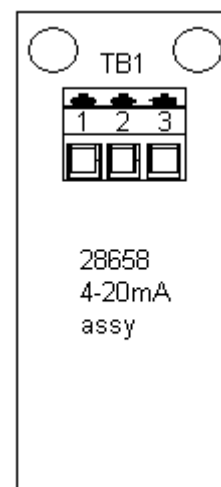
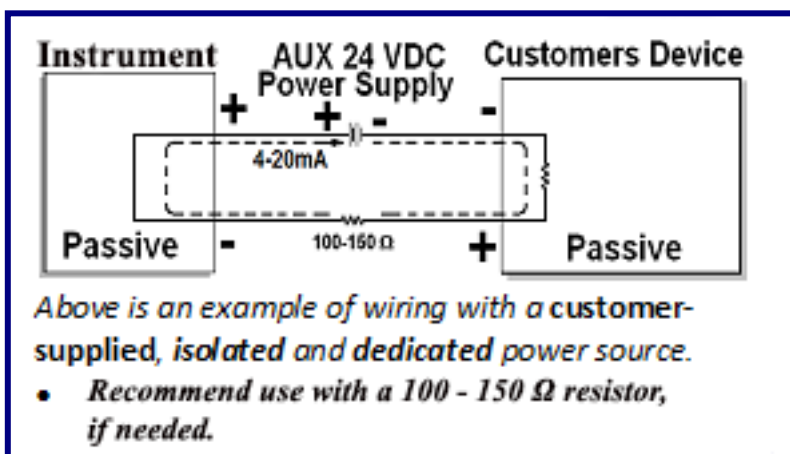

Connections are as follows:

Pin 1	+ 4-20mA
Pin 2	- 4-20mA

1. Press and hold the **UNITS** key for three (3) seconds

NOTE: If 4-20mA Analog Output has been installed and programmed, setting 4-20 to **NO** in the **APPS Menu** will prevent access to it from the front panel while the analog output continues to operate.

2. Select **GROSS** or **NET**.

- ✓ The **4-20mA Analog Output** will continue to track the selection regardless of the currently selected Weigh Mode.

3. Press **MENU**.
4. Press the **right arrow** key to toggle the available settings.
5. Press **ENTER** to select an option.

Available selections include the following.

- Gross
- Net

4.8.1. Programming the 4mA Weight Value

4.20 Lo displays, followed by the weight setting.

1. If the output needs fine-tuned, use the left or right arrows to adjust. **Adj Lo** will display.
2. Press **ENTER**
3. Key in the desired Weight Value with the 0-9 keys. This weight value will result in a 4mA output.
4. Press **ENTER**

When complete, the program will advance to the 20mA menu.

4.8.2. Programming the 20mA Weight Value

4.20 Hi displays, followed by the weight setting.

1. If the output needs fine-tuned, use the left or right arrow keys to adjust. **Adj Hi** will display.
2. Press **ENTER**
3. Key in the desired Weight Value with 0-9 keys. This weight value will result in a 20mA output.
4. Press **ENTER** The program will advance to the 20mA menu.

When complete, the FB2255 will return to weigh mode.

NOTE: Fine tune adjustment is available in firmware version 2.04 and after.

Section 5: Fieldbus/Bluetooth

5.1. Fieldbus Installation

Fieldbus is a general term that describes an all-digital two-way communications system that interconnects measurement and control equipment such as sensors, actuators and controllers.

- ✓ Fieldbus traces its beginnings in the automotive industry, where efforts to simplify and reduce wiring resulted in a multiplexed **Controller Area Network (CAN)** system of modules installed at various points of a car

For example, many cars have multiple controls on the door, such as power-window, power-mirror, power-lock and power-seat controls.

- ✓ To eliminate the thick bundle of wires of the older method, a driver's-door module monitors all of the switches.
- ✓ If the driver presses the window switch, the door module closes a relay that provides power to the window motor.
- ✓ If the driver presses the switch to adjust the passenger-side mirror, the driver's door module sends a packet of data onto the communication bus of the car.
- ✓ This packet tells a different module to energize one of the power-mirror motors. In this way, most of the signals that leave the driver's door are consolidated onto the two wires that form the communication bus.

As time has progressed, many different Fieldbus types have been developed, each with different characteristics and specifications.

- ✓ Very simply, they serve as a Local Area Network (LAN) for instrumentation used in automatic process control and manufacturing applications.
- ✓ The LAN is a digital, bi-directional, multi-drop, serial-bus communications network used to link field devices (often referred to as "Nodes"), such as controllers, transducers, actuators and sensors.

There are a number of different manufacturers that produce Fieldbus devices.

- ✓ Each produces different hardware interfaces, wiring and connector types, speed, and the amount of bytes of data that can be exchanged on the network, among other things.

Additionally, the current Fieldbus communications network is replacing the older 4-20mA Analog Signal.

- ✓ The older 4-20mA analog signal requires each device to have its own set of wires and its own connection points.
- ✓ A Fieldbus eliminates this need as, generally, twisted pair wiring is used.
- ✓ All devices on the network are now connected together.
- ✓ Fairbanks Scales offers five different fieldbus devices modules; PROFIBUS®-DP, ControlNet®, DeviceNet™, Modbus®, and Ethernet/IP.

For more information and EDS files, see <http://www.hms.se/default.shtml>.

5.2. Fieldbus Connections

The term **FIELDBUS** usually describes an all-digital two-way communications system that interconnects measurement and control equipment such as sensors, actuators and controllers.

The **Fieldbus** assembly connects to the 32-pin header on the FB2255 main PCB Assembly.

It is provided with **two (2) standoffs** which support the right side of the card.

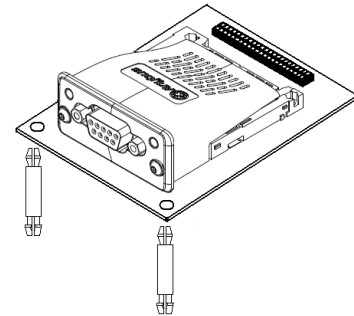

5.2.1. Overview of Terms

There are currently **five (5) different of Fieldbus Interfaces** listed as standard accessories for the FB2550 Instrument.

- ✓ **DEVICENET™ (29578)**
 - A network system to interconnect control devices for data exchange.
 - It uses a differential serial bus, called **Controller Area Network (CAN)**, as the backbone technology and defines an application layer to cover a range of device profiles.
- ✓ **CONTROLNET™ (31979)**
 - An open control network in real-time, for high-throughput applications.

5.2.1. Overview of Terms, Continued

PROFIBUS®-DP (29576)

- Non-powered two-wire (RS485) network, with **up to 126 nodes**, transferring a maximum of 244 data bytes per node per cycle.

MODBUS-TCP (34032)

- Serial network communications in a master/slave (request/response) type relationship using either ASCII or RTU (Remote Terminal Unit) modes.
- Non-powered two-wire (RS485) network, with **up to 126 nodes**, transferring a maximum of 244 data bytes per node per cycle.

ETHERNET/IP (29873)

- Dynamic Host Configuration Protocol (DHCP) is used for address requests.
- The data is transmitted continuously from this module.
- The IP address may be made static by downloading the **IP Configuration Tool Software**.

ETHERNET/IP can be easily confused as a simple combination of EtherNet and the Internet Protocol. Instead, it is an **Industrial Application Layer Protocol** used for communication between industrial control systems and their components.

- Such components include Programmable Automation Controller, Logic Controller, or an I/O System.
- The “IP” in EtherNet/IP is not an abbreviation for “Internet Protocol”, but instead, it stands for “**Industrial Protocol**”.

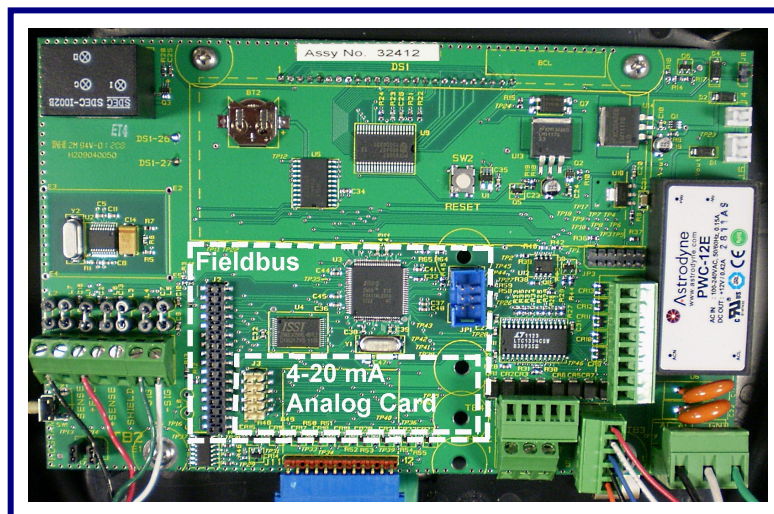

5.2.2. DeviceNet™ (29578)

DEVICENET is a low-cost communications link that connects industrial devices to a network, eliminating expensive hardwiring.

- It is based on a broadcast-oriented, communications protocol the **CAN**.
- The **CAN Protocol** was originally developed by BOSCH for the European automotive market for replacing expensive wire harnesses with low-cost network cable.
- The **CAN Protocol** has fast response and high reliability for applications like anti-lock brakes and air bags.

DEVICENET™ also provides power to the network. This allows devices with limited power requirements to be powered directly from the network.

- This reduces connection points and physical size.
- The maximum network size is **up to 64 Nodes**, with message data packets **up to 8 bytes**.

Wire	SIGNAL	DESCRIPTION
1	V	Negative bus supply voltage
2	CAN_L	CAN low bus line
3	SHIELD	Cable shield
4	CAN_H	CAN high bus line
5	V+	Positive bus supply voltage



Additional information available for DeviceNet™ information and EDS files:
<https://www.anybus.com/support/file-doc-downloads/anybus-compactcom-30-series>

5.2.2. DeviceNet™ (29578), Continued

NETWORK STATUS LED

STATE	INDICATION
OFF	Not online/ No power
GREEN	Online, one or more connection established
FLASHING GREEN (1 Hz)	Online, no corrections established
Red	Critical link failure
Flashing Red (1 Hz)	One or more connections timed out
Alternating Red/Green	Self-test

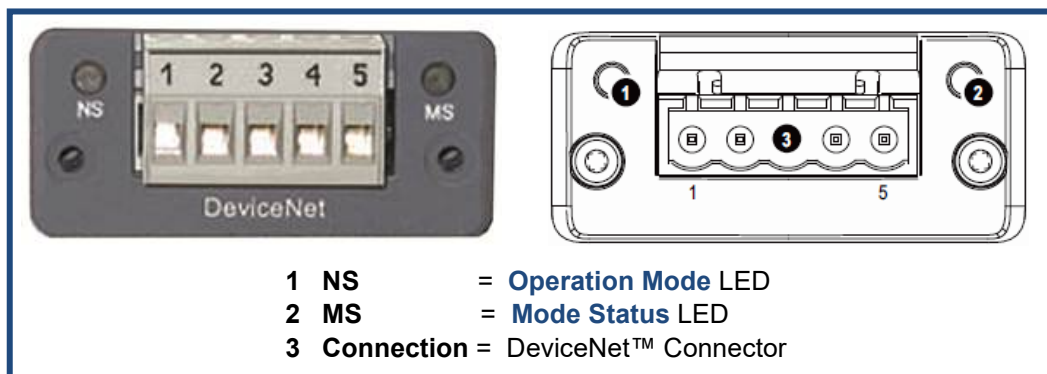

MODULE STATUS LED

STATE	INDICATION
OFF	No power
GREEN	Operating in normal condition
FLASHING GREEN (1 Hz)	Missing/Incomplete configuration/ Device needs commissioning
Red	Unrecoverable fault(s)
Flashing Red (1 Hz)	Recoverable fault(s)
Alternating Red/Green	Self-test

5.2.3. ControlNet™ (31979)

CONTROLNET™ is an open control network running in “real-time”, for high-throughput applications.

- It uses a **Control and Information Protocol (CIP)**, combining the functionality of an I/O Network and a Peer-to-Peer Network.
- **CONTROLNET** is based on the **Producer/Consumer Model**, permitting all nodes on the network to simultaneously access the same data from a single source.
- Maximum of **99 nodes**, with no minimum distance between nodes
- The Control net card uses BNC connectors.



SPECIAL NOTES

For **signal redundancy**, both connectors should be used.

- If not, use either **Connector A** or **B**.

Network Status LED A and **Module Status LED** correspond to **LED 1** and **LED 2** in the instance attributes of the **Anybus Object**.

- They are available in the application interface, but the LED placement on the front does not conform to the standard **Anybus CompactCom** placement of **LED 1** and **LED 2**.

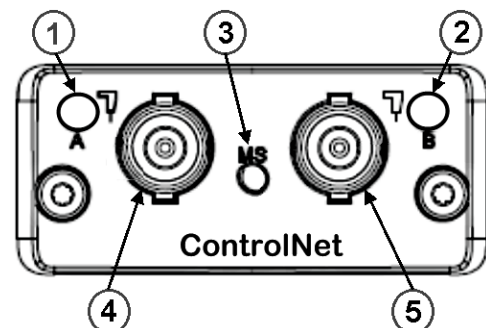

Additional information available for ControlNet Information and EDS files:

<https://www.anybus.com/support/file-doc-downloads/anybus-compactcom-30-series>

5.2.3. ControlNet™ (31979), Continued

NETWORK STATUS

LED	STATE	INDICATION
A and B	OFF	Not online / No power
	Flashing Red (1 Hz)	Incorrect node configuration, duplicate MAC ID etc.
	Alternating Red/Green	Self test of bus controller
	Red	Fatal event or faulty unit
A or B	OFF	Channel is disabled
	Alternating Red/Green	Invalid link configuration
	Flashing Green (1 Hz)	Temporary errors (node self-corrects) or node is not configured to go online.
	Green	Normal operation
	Flashing Red (1 Hz)	Media fault or no other nodes on the Network

MODULE STATUS

STATE	INDICATION
OFF	No power
GREEN	Operating in normal condition, controlled by a Scanner in RUN state.
FLASHING GREEN (1 Hz)	The module has not been configured or the Scanner is in the Idle state.
Red	Unrecoverable fault(s), EXCEPTION,
Flashing Red (1 Hz)	Media fault or no other nodes on the Network

No.	DESCRIPTION
1	Network Status LED A
2	Module Status LED
3	Network Status LED B
4	ControlNet™ Connector A
5	ControlNet™ Connector B

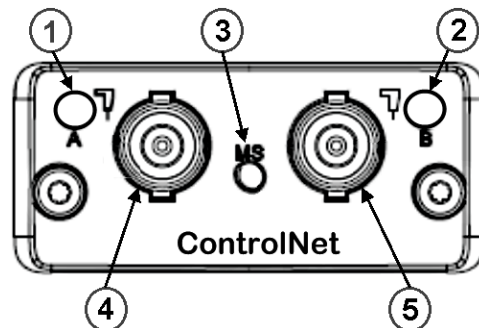

5.2.4. Profibus®-DP (29576)

PROFIBUS®-DP is one of the best-known industrial fieldBus protocols from Europe.

- It is an established standard, used in a wide range of applications as a multi-application communications link for industrial devices.
- The ProfiBus protocol was originally developed by a committee founded by the German government.



PROFIBUS®-DP utilizes a **non-powered two-wire (RS-485) Network**.

- A ProfiBus Network may have **up to 126 nodes**, transferring a maximum of **244 bytes data per node/ per cycle**.
- Baud (Communication) Rates are selectable, and overall end-to-end network distance varies with speed.
- The maximum standard Baud Rate is **12Mbps**, with a maximum distance of **100M (328ft)**, and **1200M (3936 ft.)** at **93.75Kbps** without repeaters.
- **PROFIBUS®-DP** connects to a wide variety of field devices including the following:
 - *Discrete and analog I/O Drives.*
 - *Robots.*
 - *HMI/MMI products.*
 - *Pneumatic valves.*
 - *Barcode readers.*
 - *Weigh scales.*
 - *Transducers.*
 - *Flow measuring equipment.*

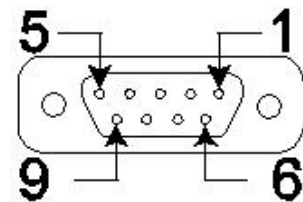

PIN	SIGNAL	DESCRIPTION
3	B-Line	Positive RxD/TxD, Rs485 level
4	RTS	Request to Send
5	GND	Ground (Isolated)
6	+5 Bus Output	+5V termination power (Isolated, short circuit protected)
8	A-Line	Negative RxD/TxD, RS485 level

5.2.4. Profibus®-DP (29576), Continued

OPERATION MODE LED

LED STATE	DESCRIPTION
OFF	Not online or No power
Green	Online/ Data Exchange
Flashing Green	Online, clear
Flashing Red (1 flash)	Parameterization error
Flashing Red (2 flashes)	Profibus configuration error

MODULAR STATUS LED

LED STATE	DESCRIPTION	COMMENTS
OFF	No power - OR – not initialized	Module state = “ SETUP ” OR NW-INIT ”
Green	Initialized	Module has left the NW_INIT state
Flashing Green	Initialized, diagnostic events(s) present	Extended diagnostic bit is set
Red	Exception error	Module state = EXCEPTION

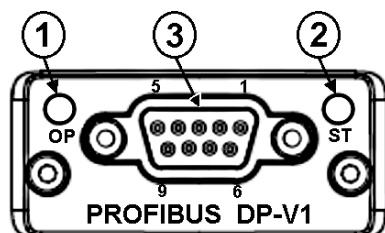

NO.	DESCRIPTION
1	Communication LED
2	Device Status LED
3	Profibus® Interface

Additional information available for PROFIBUS®-DP Information and GSD files:
<https://www.anybus.com/support/file-doc-downloads/anybus-compactcom-30-series>

5.2.5. MODBUS TCP (34032)

MODBUS (34032) TCP was originally developed in 1978 to exchange information between devices on the factory floor.

It developed into the standard for exchanging data and communication **MODULE STATUS** information between PLC systems.

- Modbus-TCP devices communicate over a **Serial Network** in a **master/slave** (request/response) type relationship.
- Uses either the **ASCII** (American Standard Code for Information Interchange) **mode** or the **RTU** (Remote Terminal Unit) **mode**.

In the **ASCII MODE**, two eight-bit bytes of data are sent as two ASCII characters.

- The primary advantage of ASCII mode is the flexibility of the timing sequence.
- Up to a one second interval can occur between character transmissions without causing communication errors.

In the **RTU MODE**, data is sent as two four-bit, hexadecimal characters, providing for higher throughput than in ASCII mode for the same baud rate.

- Modbus Plus communicates using a single twisted pair of wires in one shielded cable (**#18AWG**).
- Modbus Plus **does NOT provide power** on the network.

Maximum of up to **32 Nodes**, and up to **64** with a Repeater.

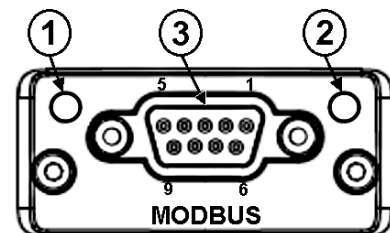

NO.	DESCRIPTION
1	Communication LED
2	Device Status LED
3	Modbus Interface

COMMUNICATION LED

LED STATE	DESCRIPTION
OFF	No power - <i>OR</i> - no traffic
YELLOW	Frame reception or transmission
RED	A fatal error has occurred

5.2.5. Modbus TCP (34032), Continued



DEVICE STATUS LED

LED STATE	INDICATION
OFF	Initialize – OR – no power
GREEN	Module initialized, no error
RED	Internal error – OR –major unrecoverable fault
RED, SINGLE FLASH	Communication fault or configuration error Case 1: Invalid settings in Network Configuration error Case 2: Settings in Network Configuration Object has been changed during runtime (i.e. the settings do not match the currently used configuration).
RED, DOUBLE FLASH	Application diagnostics available.

MODBUS-TCP INTERFACE

PIN	DIRECTION	SIGNAL	COMMENT
Housing	—	PE	Protective Earth
1	—	GND	Bus polarization, ground (isolated)
2	Output ³	5V	Bus polarization power +5V DC (isolated)
3	Input	PMC	Connect to pin #2 for RS-232 operation
4			
5	Bidirectional	B-LINE	RS-485 B-Line
6			
7	Input	RX	RS-232 Data Receive
8	Output	TX	RS-232 Data Transmit
9	Bidirectional	A-Line	RS-485 A-Line

Additional information available for Modbus®-TCP Information and GSD files:

<https://www.anybus.com/support/file-doc-downloads/anybus-compactcom-30-series>

5.2.6. Ethernet/IP Diagnostic LEDs

The Ethernet/IP module uses Dynamic Addressing.

- Dynamic Host Configuration Protocol (DHCP) is used for address requests.
- The data is transmitted continuously from this module.
- The IP address may be made static by downloading the **IP Configuration Tool Software** from the following site:
<https://www.anybus.com/support/file-doc-downloads/anybus-compactcom-30-series>

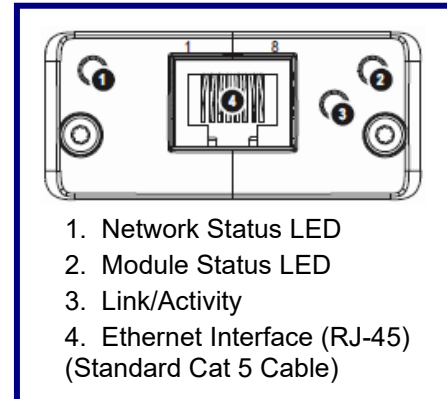

- Using this download, it is possible to change the IP, Sub Net and Gateway addresses of an Ethernet/IP Module.
- To change an address, double click on the IP address field and enter the changes.

Shown below is the Network Status LED Chart

STATE	DESCRIPTION
Off	Not online / No power
Green	Online, one or more connections established.
Flashing	Online, no connections established
Red	Duplicate IP address, FATAL error
Flashing Red	One or more connections timed out

Shown below is the Module Status LED Chart

STATE	DESCRIPTION
Off	No power
Green	Controlled by a scanner in Run state
Flashing Green	Not configures, or Scanner in idle state
Red	Major fault (EXCEPTION-state, FATAL error, etc.)
Flashing Red	Recoverable fault(s)

Shown below is the Link / Activity LED Chart

STATE	DESCRIPTION
Off	No link, no activity
Green	Link established
Flickering Green	Activity

Additional information available for Ethernet IP information and EDS files:

<https://www.anybus.com/support/file-doc-downloads/anybus-compactcom-30-series>

5.3. Bluetooth® Technology Device

The Bluetooth® Option replaces direct wiring between two devices.

- ✓ The Bluetooth® Interface uses either **Port 1** or **Port 2 Serial Output**.
- ✓ RS232 Serial Interface to Bluetooth® Interface with a range of **100 meters (328 feet)**.

The Bluetooth® Option operates either as a Client or Server, depending on its connecting device.

If connected to a printer, the FB2255 will be a **Server**. If connected to a PC, it is a **Client**.

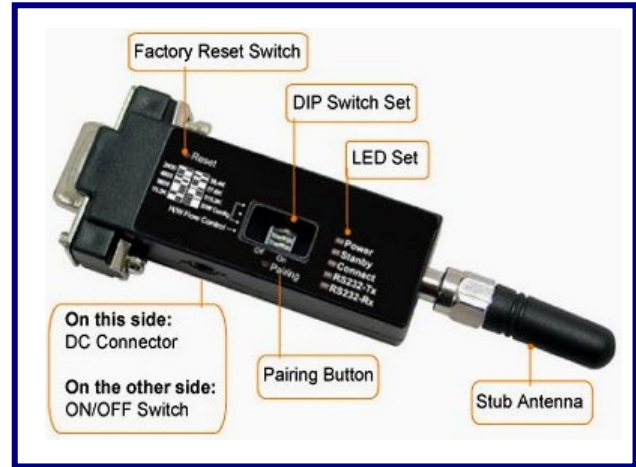

Shown below are some Bluetooth® products with their features.

MODEL NO.	MODEL NAME	DESCRIPTION
29515	Bluetooth® Accessory, Class I , for non-FB2255 device	<ul style="list-style-type: none"> • Power source required for non-FB2255 side of the connection. • 5 - 12 VDC, USB power cable provided. • PC interfacing software provided.
29639	AC Power adapter for Bluetooth® Accessory 29215	<ul style="list-style-type: none"> • For use if USB power cable not applicable.
29516	Bluetooth® Accessory, Class I , FB2255	<ul style="list-style-type: none"> • FB2255 provides power • RoHS compliant • Includes cable 29402

The **Bluetooth® device** is supplied with a **DB-9 female connector**.

Shown below is the wiring code / color code to connect the **FB2255** and the **Bluetooth® Device**.

FB2255 TB4A OR TB4B	BLUETOOTH® DEVICE	FB SUPPLIED CABLE
Pin 1	Pin 2	Red
Pin 2	Pin 3	White
Pin 4	Pin 5	Black
Pin 3 ON TB4C	Pin 9	Green

5.3. Bluetooth® Technology Device, Continued

Set the **4-position Dip Switch** on each device as shown below.

1,2,3	ON
4	OFF

Baud Rate	9600
Data Bits	8
Parity	None
Stop Bit	1

Follow these steps to installing the **Bluetooth® Devices**.

1. Turn on both Bluetooth® Devices with the **SLIDE SWITCH** on their sides.
2. Press the **RESET BUTTON** on each one.
3. Press the **PAIRING BUTTON** of **Device #1** for two (2) seconds
 - ✓ The Standby LED turns **OFF**.
 - ✓ The **Connect LED** blinks three (3) times every two (2) seconds.
 - ✓ Keep the power **ON**.



4. Press the **PAIRING BUTTON** of **Device #2** for two (2) seconds.
 - ✓ The Standby LED turns **OFF**.
 - ✓ The **Connect LED** blinks three (3) times every two (2) seconds.
5. Press the **Pairing Button** again for two (2) seconds until the **Connect LED** blinks every half (½) second.

- ✓ Wait for **Devices #1** and **#2** to connect to each other.
- ✓ The **Connect LEDs** of both will be solid green.
- ✓ This connection process takes about ten (10) seconds.
- ✓ If any other Bluetooth® devices are nearby, it may take longer.

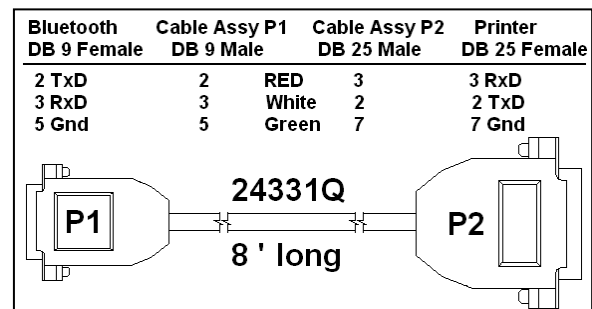

5.3. Bluetooth® Technology Device, Continued

6. Turn **Device #1 OFF**, and then back **ON**.
 - ✓ The **Connect LED** light blinks green twice every three (3) seconds.
7. Turn **Device #2 OFF**, and then back **ON**.
8. The **Connect LED** light blinks green once every second.

Configuration is now complete. Both devices are configured to make automatic connection to each other whenever they are powered on.

Section 6: PC2255 Utility Software

CAUTION

USING THIS PC2255 UTILITY PROGRAM CAN ALTER
PROPER CALIBRATION AND USER FUNCTIONS.

OWNER ASSUMES ALL RISKS WHILE USING THIS PROGRAM!

THE CUSTOMER WILL BE RESPONSIBLE FOR ALL
SERVICE DEPARTMENT COSTS TO RESTORE THE
INSTRUMENT TO ITS PROPER OPERATIONS.

6.1. Introduction

- ✓ The PC2255 utility software program can be used to set up and configure the FB2255.
- ✓ It is required in order to program certain features, such as custom units and custom ticket vector programming.
- ✓ The FB2255 uses **Port 2** to communicate to the computer.

6.2. Communication Settings

1. Configure the FB2255 Port 2 as noted in Table 1 below:
 - a. Press and hold the Internal Program Switch until **SetUP** displays.
 - b. Use the Right Arrow key to scroll through each menu item until **Port 2** displays
 - c. See Sections 2.3.9 through 2.3.14 for configuration instructions.
 - d. Exit to weigh mode.

Baud Rate	9600
Data Bits	8
Parity	None
Stop Bit	1
Mode	Continuous

Table 1

2. On the PC Launch the **PC2255** Utility.
 - An image of the FB2255 will display on the computer monitor.

6.2. Communication Settings, Continued

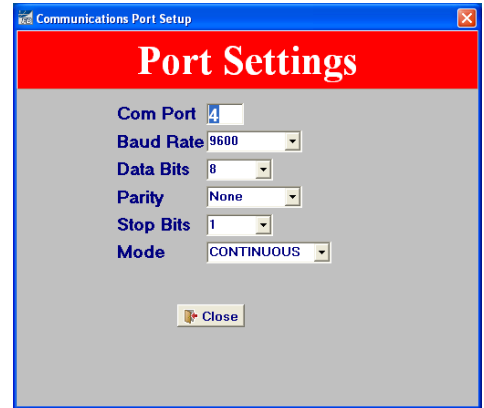

3. Access the **COM Port Settings** of the computer by pressing **F2**.
4. Configure the Com Port connected to the FB2255 via the pop-up menu to match the settings in Table 1 above.
5. Close the pop-up menu when complete.
6. To the left side of the weight display, the legend "**CONNECTED**" with a rotating baton will be displayed.
 - The weight display will duplicate what is shown on the FB2255.
7. Left-clicking the mouse on any key will transmit that command to the FB2255.
 - This excludes the **PRINT** key.
 - The legend "**COMMAND SENT!**" will display at the right.
 - Mouse-clicking the **ON/OFF** key will terminate the PC2255 software program.

6.3. Communication Files

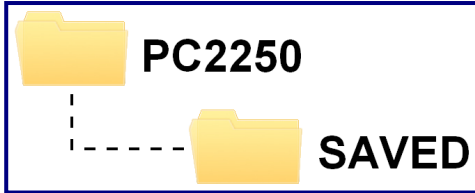

The default folder for all saved/uploaded parameter files is **PC2255\SAVED**.

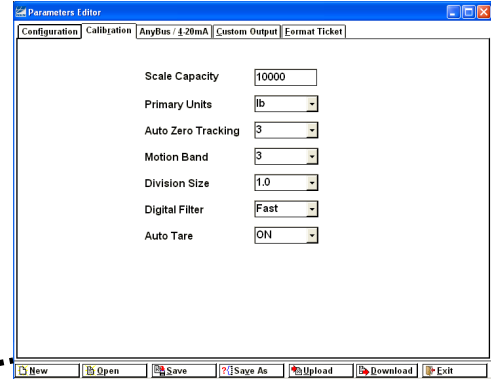

6.4. Menu Bar

The PC2255 menu bar is located at the bottom of the display.



BUTTON	FUNCTION
NEW	Loads the Parameters Menu with FB2255 default settings.
OPEN	Opens the SAVED folder to select a file.
SAVE	Saves the currently named file.
SAVE AS	Saves the current file and prompts for a file name.
UPLOAD	Uploads the current FB2255 settings to the PC2255.
DOWNLOAD	Downloads the current PC2255 settings to the FB2255.
EXIT	Exits the program.

1. Press the **UPLOAD** button to retrieve the current FB2255 settings to the PC2255.

✓ The FB2255 displays “PC”.

2. Press the **INTERNAL PROGRAMMING SWITCH**.

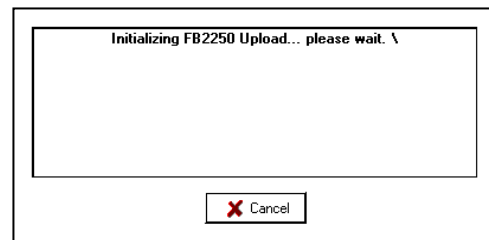

6.4. Menu Bar, Continued

3. When the process is complete, click **OK**.



4. Click the **DOWNLOAD** button to retrieve the current PC2255 settings to the FB2255.

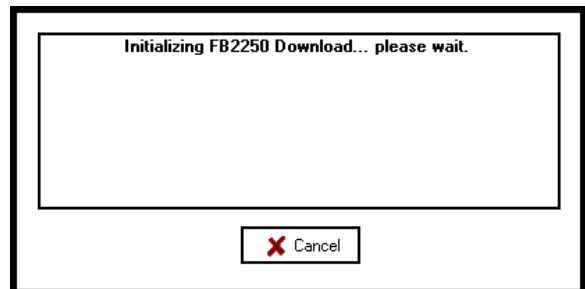

The FB2255 displays “PC”.

5. Press the **INTERNAL PROGRAMMING SWITCH**.



6. When complete, click **OK**.



7. Press **EXIT** to close the **Parameter Editor**.

6.5. Configuration

1. Press **F4** to enter the **Parameters Editor**.

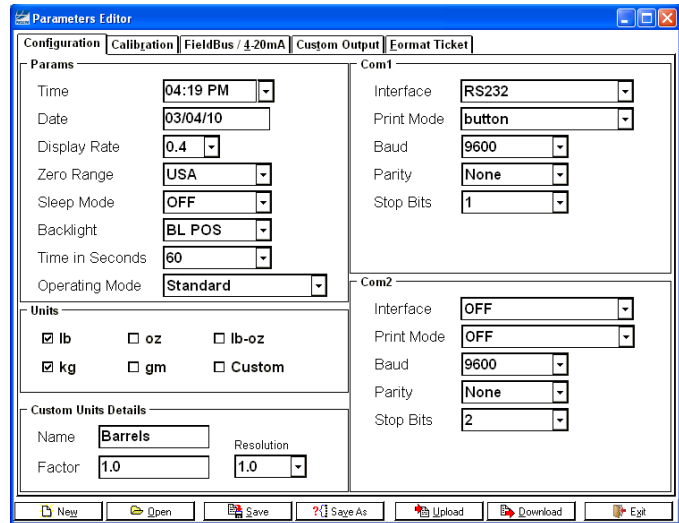

Use one of the following methods that apply to programming the features.

- ✓ Click on the data item to highlight it, then type in the replacement data.
- ✓ Click the drop down arrow and selecting an available item.
- ✓ Click on the checkmark to select the option(s).
- ✓ Input the custom unit factor to set the conversion factor of the current primary weight data.

CUSTOM UNIT PROGRAMMING EXAMPLE

To convert pounds to dry barrel units, enter the conversion factor, resolution and custom legend. The current **primary weight** will be multiplied by the **conversion factor**, rounded off to the **custom resolution** and printed with a custom legend.

6.6. Calibration

Settings from this window include the following options.

- Scale capacity
- Primary Units
- Auto Zero Tracking (AZT)
- Motion Band (BAL)
- Division Size
- Digital Filter
- Auto Tare settings

Actual test weight calibration is performed with the FB2255 front panel keys.

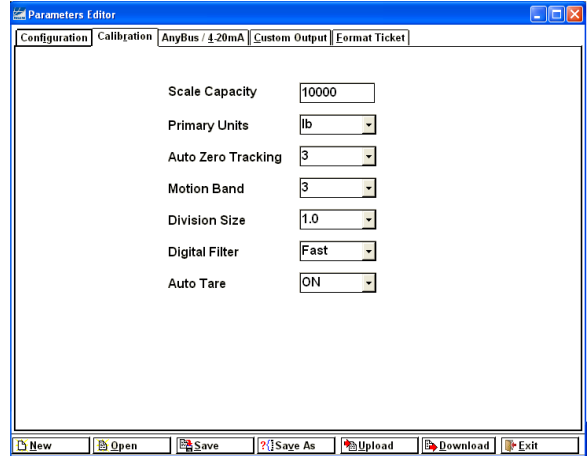

6.7 First time connection using PC225X PC Utility and FB225X Ethernet TCP/IP option.

1. With the FB225X connected to the ethernet network, launch the PC225X PC Utility from the PC on the same network as the FB225X.

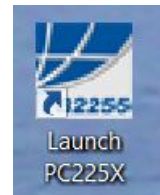

2. Change the interface from RS232 to TCP/IP by clicking on the button.
3. Select the PC Utility type based on the instrument you will be connecting to. Choose PC2250 or PC2255.



NOTE: If the ethernet card has been previously configured, skip to step 23.

4. Click F4 to open the Configuration window.

5. Select the **IP CONNECTION** Tab.

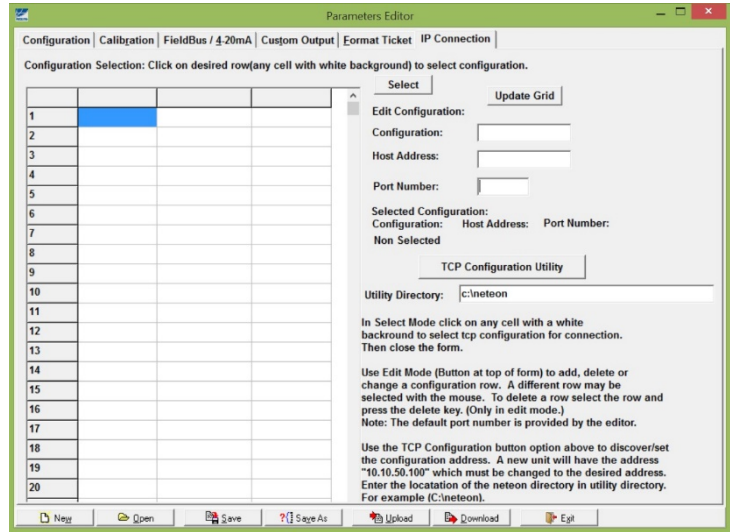

6. Click the **TCP CONFIGURATION UTILITY** button.

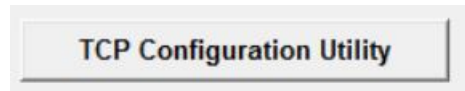

7. The NETEON Utility will open.

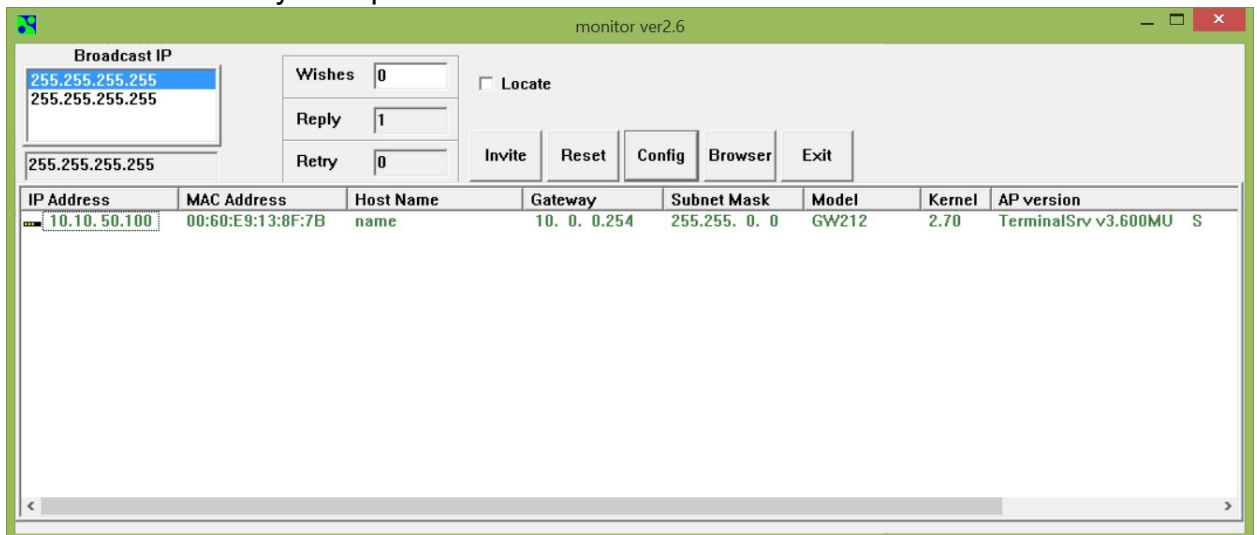

8. The default IP (10.10.50.100 or 10.0.50.100) of the ethernet device should show.
9. Highlight the IP address shown by clicking on it.
10. Select the **CONFIG** button.
A new dialog box will open.



11. Obtain network setting details from the customer's IT personnel and enter the information in the dialog box.
 - a. **NOTE:** AUTO IP sets the card to DHCP



12. Set the USER ID and PASSWORD
 - a. Default = admin with no password
13. Highlight the IP address shown by clicking on it.
14. Click the **CONFIG NOW** button to write the change to the ethernet card.

15. Click the **BROWSER** button.



16. You will be prompted for the USER ID and PASSWORD previously entered.

17. The **OVERVIEW** window will open showing the current addresses and settings for the ethernet card.

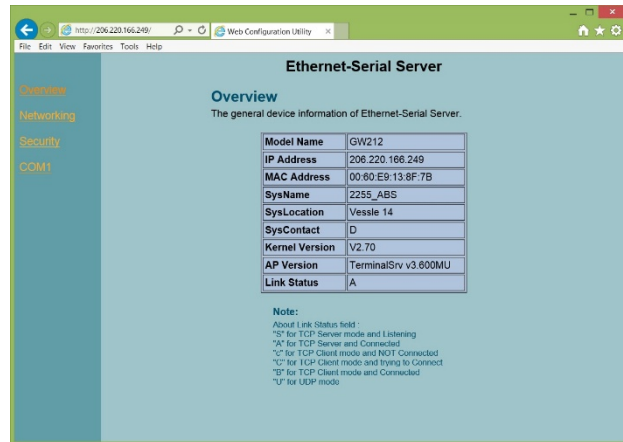

18. If additional network configuration is required, click the **NETWORKING** link.

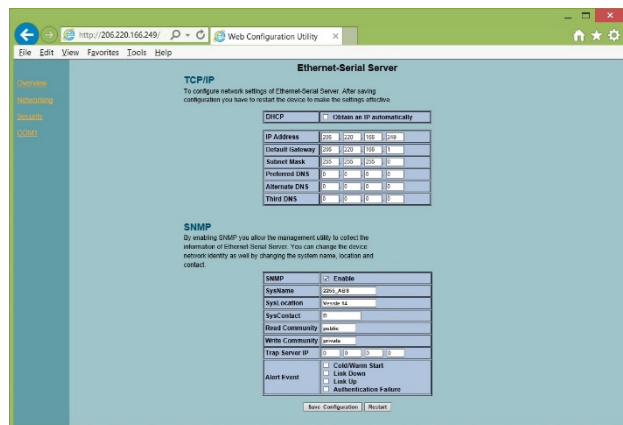

19. To change the PASSWORD, click the **SECURITY** link.

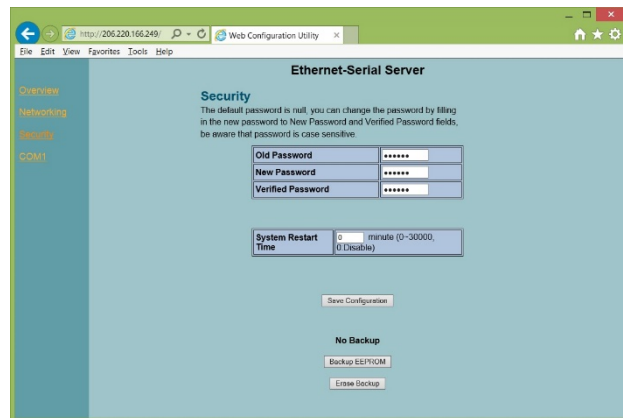

20. Do NOT make any changes under the COM1 link.

21. Close the browser window when you are done.

22. Click the **EXIT** button to close the configuration utility.



23. Return to the PC225X Utility and select the **IP CONNECTION** tab.
24. If the **SELECT** button is available, proceed to the next step, if it is not click on the **EDIT** button then proceed to the next step.
25. In the **CONFIGURATION** field, enter a human readable name to identify the FB225X instrument to connect to.

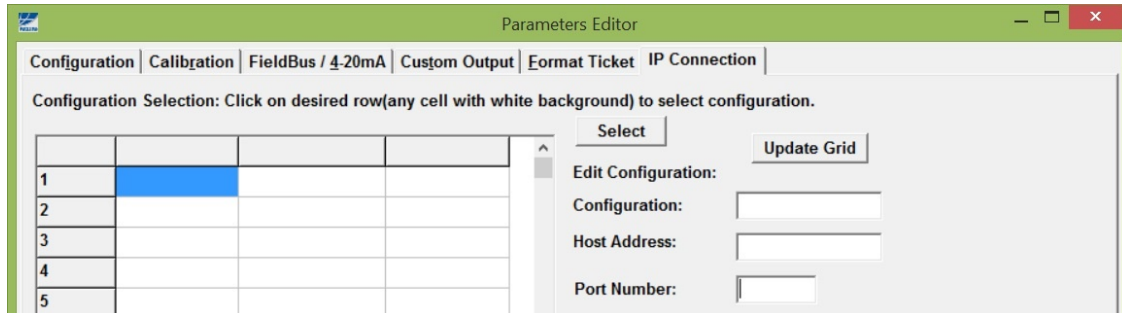

26. In the **HOST ADDRESS** field, enter the IP address for the FB225X being connected.
27. Default PORT NUMBER is 4660.
28. Once complete, select **UPDATE GRID**.

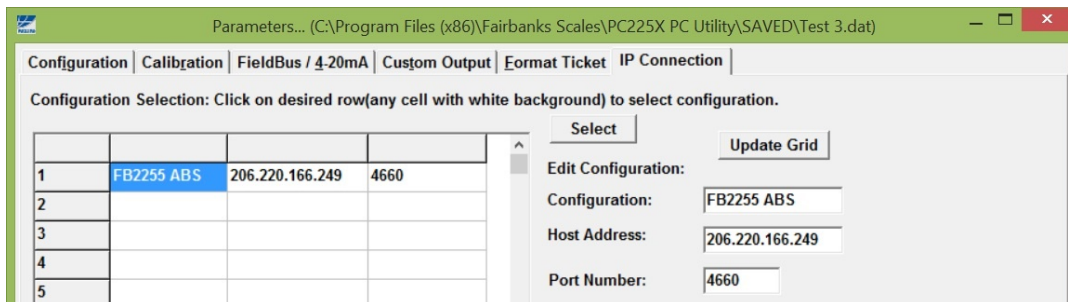

29. Save the PC225X Configuration file using the **SAVE AS** button.
30. Press **EXIT** to close the Configuration tool.
31. Weight should now display on the PC225X Utility.
32. The Utility will display the current IP Connect selected next to the TCP/IP button.
33. You can make Configuration changes, Upload and Download files from the PC225X Utility and the FB225X instrument.

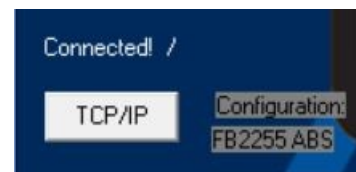

6.8. Fieldbus

The **Anybus Module** is set up using the **PC2255 Program** and configures the following parameters listed below. The FB2255 will automatically detect the Anybus module installed. No additional programming is required except the following parameters if necessary. The remainder of the fieldbus configuration and programming is performed on the fieldbus network side by the customer's network personnel.

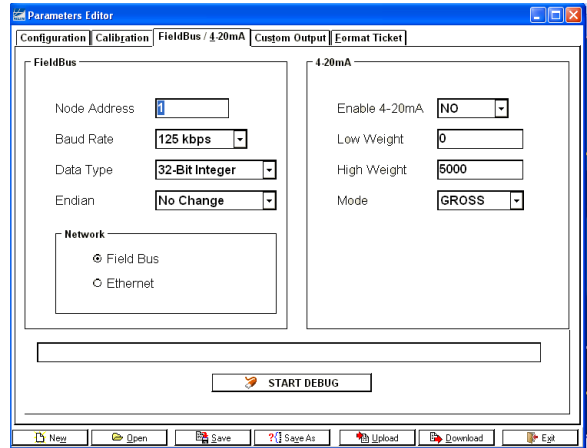

PORT 20

As part of the Ethernet IP specification, the fieldbus device uses Port 20. This port cannot be changed. This is to ensure other devices on the network are able to communicate with each other.

NODE ADDRESS

- ✓ Enter the **Node Address** of the Module.
- ✓ This is typically furnished by the customer.

BAUD RATE

- ✓ Most Anybus Modules can automatically detect the network speed by using the **Auto Baud** feature.
- ✓ Typical configurations for DeviceNet™ uses 125K bps, 250K bps or 500K bps baud rates

6.8. Fieldbus, Continued

DATA TYPE

Data can be setup to output a **32 bit Integer word** or a **32 bit floating point value**.

ENDIAN

The **Endianess** of a module is determined by the network type, but can be changed from Little Endian to Big Endian, or vice versa by using the **"CHANGE ORDER"** setting.

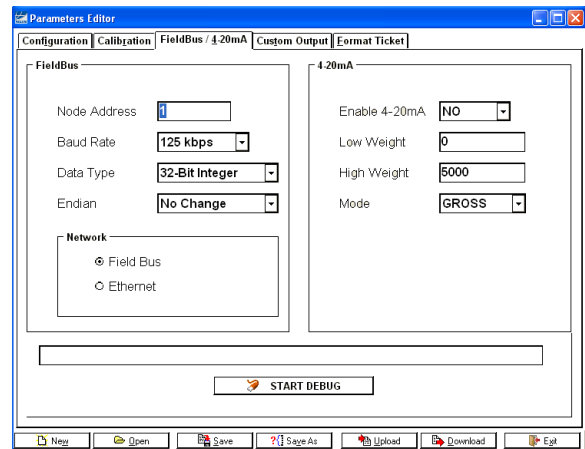

LITTLE ENDIAN FORMAT OR INTEL ORDER

In **Little Endian Format**, the *least significant byte* is stored first, followed by the next three more significant bytes.

For example, a **32bit value** of **0x12345678** would be stored in memory in **LITTLE ENDIAN** as shown below.

- ✓ Address + 0 0x78
- ✓ Address + 1 0x56
- ✓ Address + 2 0x34
- ✓ Address + 3 0x12

BIG ENDIAN FORMAT OR MOTOROLA ORDER

In **Big Endian Format**, the *most significant byte* is stored first, followed by the next three least significant bytes.

For example, a **32bit value** of **0x12345678** would be stored in memory in **BIG ENDIAN** as shown below.

- ✓ Address + 0 0x12
- ✓ Address + 1 0x34
- ✓ Address + 2 0x56
- ✓ Address + 3 0x78

6.8. Fieldbus, Continued

OUTPUT

Data from the FB2255 comprises of three (3) 32-bit words.

- ✓ **Gross Weight**
- ✓ **Tare Weight**
- ✓ **A 32bit Status Word**

- ✓ Gross and Tare weights can be selected as either a **32-bit Integer** or a **32-bit Floating Point Word**.
- ✓ The **Most significant Byte** indicates the Weigh Mode **"G"** for **Gross**, and **"N"** for **Net**.
- ✓ The **Next Order Byte** indicates **"O"** Overcapacity, **"M"** Motion of the last command received. (See INPUT Commands)

The next order byte indicates the weight units.

- ✓ **"l"** pounds
- ✓ **"k"** kilograms
- ✓ **"o"** ounces
- ✓ **"g"** grams.

The **Least Significant Byte** indicates the number of decimal places, if the weight output is selected to be a 32-bit Integer word.

- ✓ If a Floating point word is selected, this byte will be **"0"**.

INPUT

Single Byte Commands can be sent from the network.

- ✓ Although the input is read as a 32-bit word, only the **Least Significant Byte** is used in this process.
- ✓ When the command is sent and recognized, it is entered into the 32 -bit status byte in the **Least Significant Command Byte** location.
- ✓ New commands can be transmitted after transmitting a **NULL** command.

6.8. Fieldbus, Continued

RECOGNIZED COMMANDS

COMMAND	DESCRIPTION
Print Steam	See Custom Format PC2255.
Print Format Stream	CR, SPACE, STX, ENQ or Defined Poll Character
Tare	“A”
Print Ticket	“p” or “P”
Zero	“Z”
Change Gross Net Weight Mode	“G”
Change Units	“U”

DEBUG

- ✓ Data in the Anybus Module can be examined by clicking the **START DEBUG** button.
- ✓ It is stopped by clicking the **STOP DEBUG** button.
- ✓ The Start Debug and Stop Debug provides a verification of the FB2255 communicating with the fieldbus module by sending hexadecimal values which may be observed upon pressing start and stop debug.
- ✓ The **WRITE BUFFER** contains three 32-bit words.
- ✓ **Gross Weight, Tare Weight** and the **Status Word** is the data sent to the Network.
- ✓ The Contents of the **READ BUFFER**, which is the data received from the network, is displayed as a 32-bit word.

6.9. 4-20mA

WARNING: Do not physically install the 4-20mA card until the instrument is configured and calibrated (weight) to the platform.

A point-to-point or multi-drop circuit mainly used in the process automation field to transmit signals from instruments in the field to a controller. It sends an analog signal from 4 to 20mA that represents 0 to 100% of the weight displayed at the instrument. As a current loop signal, the FB2255’s 4-20ma output is a passive device which requires an isolated and dedicated power supply provided by others.

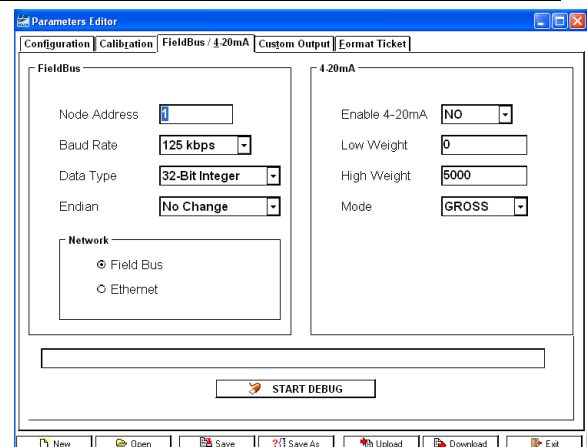

6.9. 4-20mA, Continued

Enable 4-20mA – From the drop down menu, select YES to enable the output.

Low Weight – Enter the weight value which represents the 4mA output signal.

High Weight – Enter the weight value which represents the 20mA output signal.

Mode – From the drop down menu, select weight mode which the 4-20mA will track, Gross or Net.

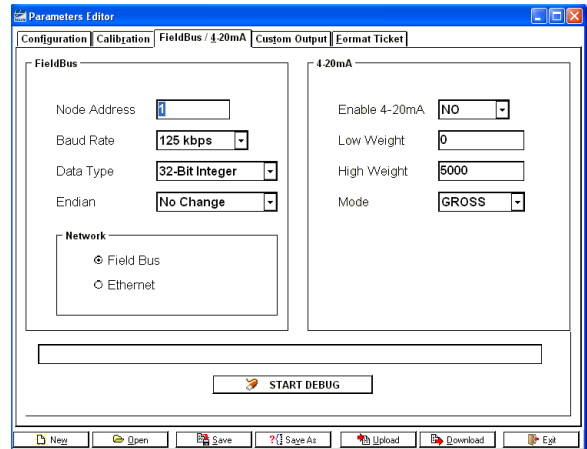

6.10. Custom Output – Settings

CHECKSUM

- ✓ This setting determines whether a **Checksum Character** is enabled or not.
- ✓ **Checksum** is an error detection method that checks the integrity of the entire string of data that is transmitted.

DELIMITED

This setting determines if a comma is added to the output string to separate data fields contained within the output string.

HARDWARE HAND SHAKING

No current function. Set up for future use.

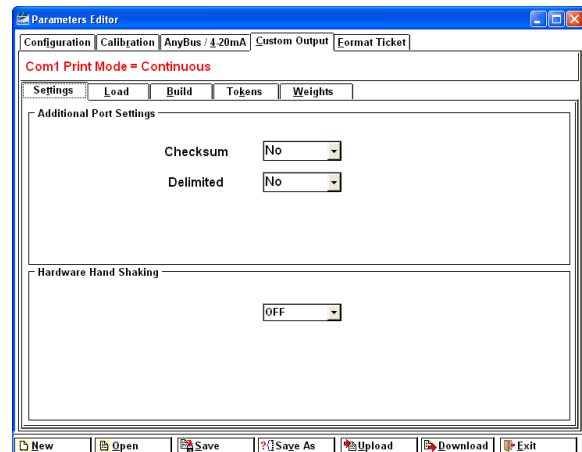

6.11. Custom Output – Load

A variety of pre-packaged **Output Strings** is available.

1. Click the **radio button** that applies.
 - **Default = Fairbanks**
2. Click OK to download the settings, or **Cancel**.

See [Appendix 1: Data Output Formats](#).

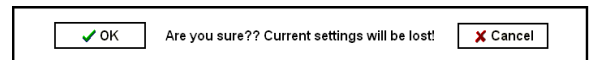
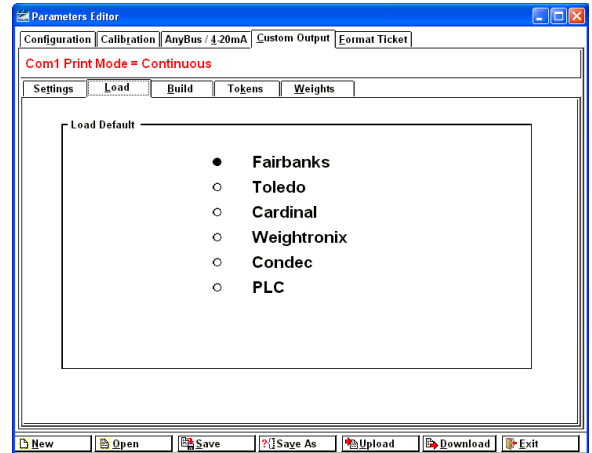

IMPORTANT NOTE:

Customized Outputs use **Port 1 only**.

The power must be cycled to the FB2255 Instrument whenever custom outputs are programmed in order for them to take effect.

6.12. Custom Output – Build

1. Customize the **Data Output String** to suit the application requirements.
 - ✓ The current structure of the output string is displayed at the bottom of the **Custom Output page**, in order of transmission from left-to-right.

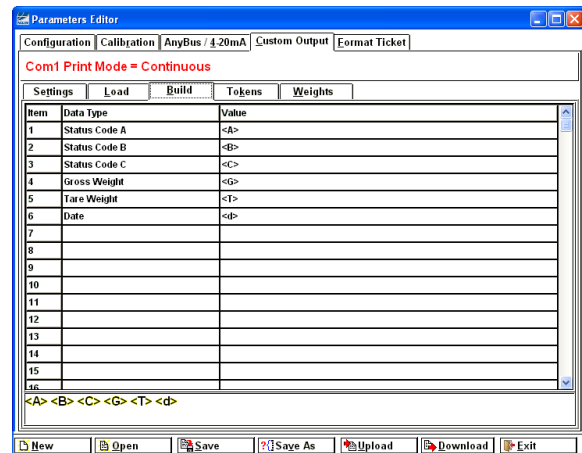

6.12. Custom Output – Build, continued

2. Right-click in the selected **DATA TYPE** field to change data items.
 - ✓ This opens a selection window containing many different data items.

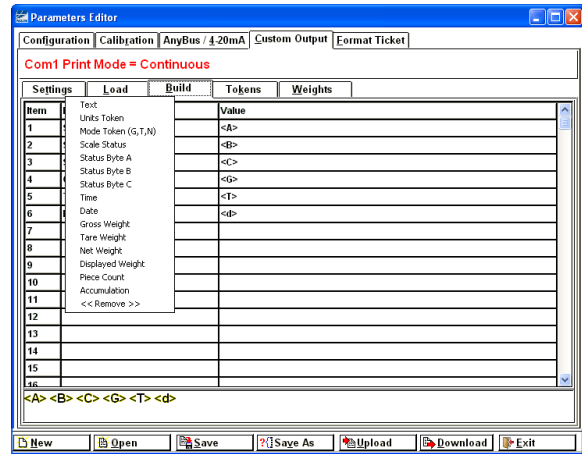

6.13. Custom Output – Tokens

1. Select from a wide variety of different characters for the polling character.
 - Start
 - Block
 - Secondary Units
 - Motion
 - Stop
 - Primary Units
 - Weighing Mode
 - Capacity Characters
2. When entering a character that is not listed, select USER DEFINED.

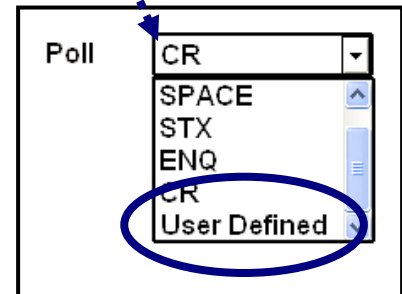
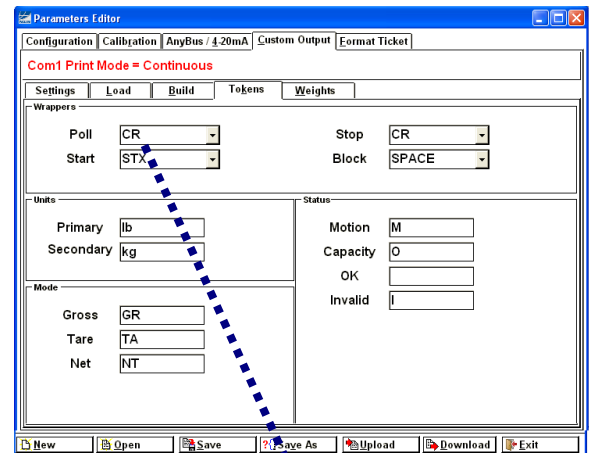

6.13. Custom Output – Tokens, Continued

This will produce an additional data entry box as shown.

1. **Right-click** in the selected **DATA ENTRY BOX** to change data items.

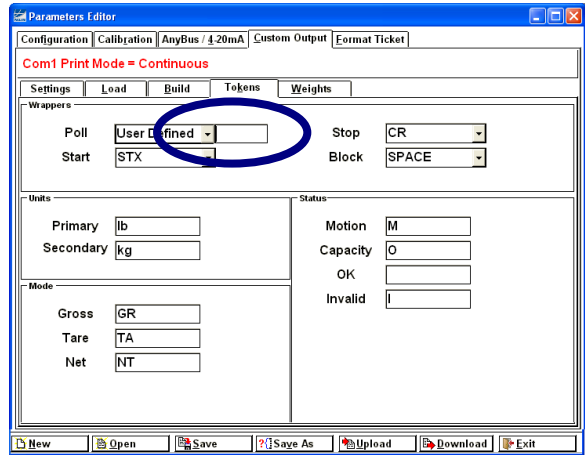

2. Make a selection, such as <SOH>, for example.
 - ✓ This inserts a **Start of Header** character... otherwise known as a **CTRL/A**, or **0x01 HEX**.
3. When entering a character not listed, select **ENTRY**.
4. Select **Entry** to insert a character using the keyboard, such as an A or a 1.

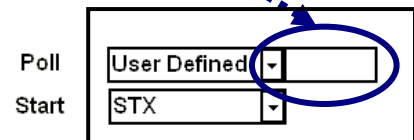
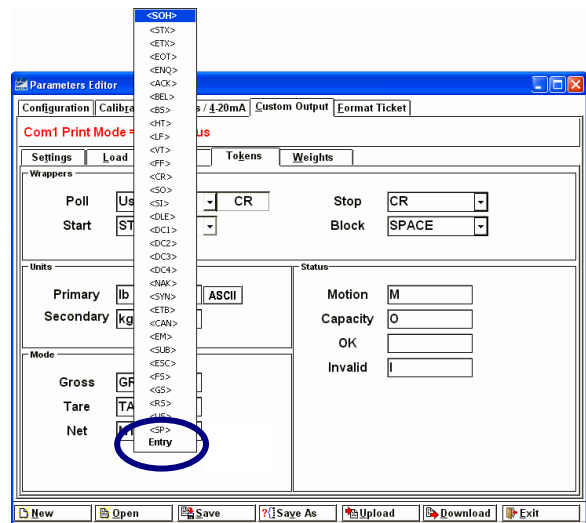

6.14. Custom Output – Weights

A variety of settings are available for the **Weight Digits** window. These choices include the following.

- Weight Digits
- Leading Zeroes
- Justification
- Decimal Point
- Fixes Decimal Places
- Include Polarity (checkbox)
- Positive Token
- Negative Token

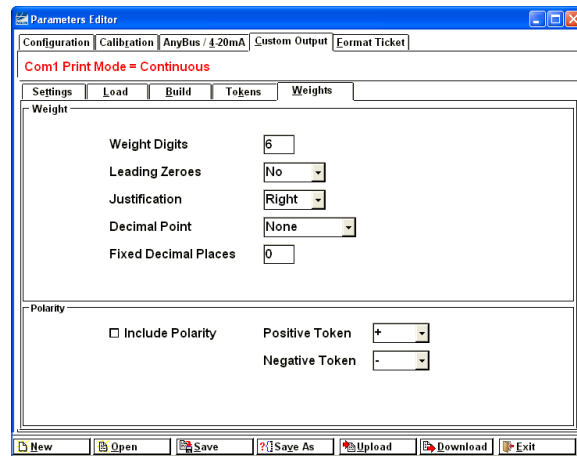

6.15. Formatting Tickets

- ✓ Formatting tickets is easily performed with this drag and drop interface.
- ✓ The blue-dashes indicate the printable area of the ticket based on the ticket size and margins entered (by the user or by default).

1. Click on the drop down arrow to select the desired ticket **Printer**.
2. Click on the drop down arrow for **INHIBIT** to select either NONE, HIGH, or LOW.
3. Enter the **Ticket Size** and **Margins** in inches.
4. Items can be removed or added from view and printing by right clicking the **VISIBLE** box under the parameter, and then selecting **NO** or **YES**.

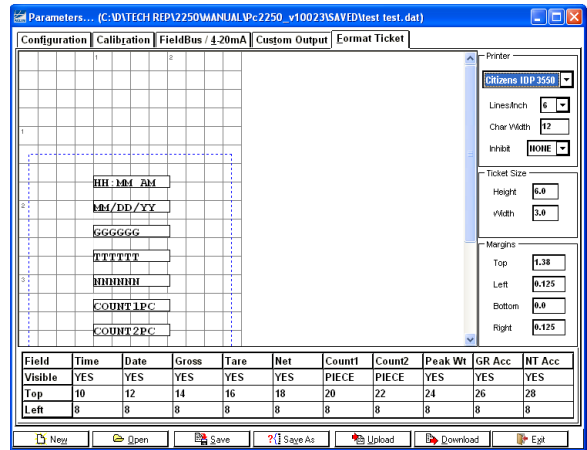

- a. Count1 options include:
 - i. NO – not visible
 - ii. PIECE – number of pieces
 - iii. CNT GR. – Gross accumulated count
- b. Count2 options include:
 - i. NO – not visible
 - ii. PIECE – Total accumulated number of pieces
 - iii. CNT NT – NET accumulated count

Field	Time	
Visible	YES	NO YES
Top	6	
Left	10	

5. Click-and-hold on a data item in the ticket window to move it to a different location or manually change the numeric values for **TOP** and **LEFT**.

Notes:

- Although the **Lines/inch** and **Char Width** settings are sent to the printer and stored, they are not being used at this time (possible future use).
- Legends such as **GROSS** cannot be disabled, and are *always included*.



6.16. Printed Examples

ACCUMULATION

Field		Count1	Count2	Peak Wt	GR Acc	NT Acc
Visible		CNT GR	CNT NT	NO	YES	YES
Top		14	16	0	20	22
Left		2	2	0	2	2

* See Section [2.9: Weight Accumulation](#) (in User Operations)

```

4 Items GR
 8333.4 lb GR Total

0 Items NT
 0.0 lb NT Total

```

Here you see a sample ticket with 4 gross accumulations stored.

```

0 Items GR
 0.0 lb GR Total

5 Items NT
8333.5 lb NT Total

```

Here you see a sample ticket with 5 NET accumulations stored. Note that the Tare weight is not shown.

```

2 Items GR
4166.7 lb GR Total

6 Items NT
9166.8 lb NT Total

```

Gross weight and NET weight can be accumulated simultaneously in the FB2255. Each Gross weight stored will be in its own register and each NET weight stored will be in its own register, completely independent from each other.



PIECE COUNT

Field	Time	Date	Gross	Tare	Net	Count1	Count2
Visible	YES	YES	YES	YES	YES	Piece	Piece
Top	2	2	6	8	10	14	16
Left	2	13	7	7	7	7	7

* See [2.12. Piece Counting](#) (in User Operations).

Container weighs 5.0 lb.

5 pieces weigh 1.0 lb

Pieces cannot be accumulated.

When **PRINT** key was pressed, 5 pieces were still on the scale.

02:04PM	02-18-14
6.0 lb GR	
5.0 lb TA	
1.0 lb NT	
5 Pieces	
0 Total Pieces	

PIECE COUNT & TOTAL

Field	Time	Date	Gross	Tare	Net	Count1	Count2
Visible	YES	YES	YES	YES	YES	Piece	Piece
Top	2	2	6	8	10	14	16
Left	2	13	7	7	7	7	7

* See [2.13. Piece Count and Total](#) (in User Operation).

Container weighs 5.0 lb.

5 pieces weigh 1.0 lb

13 pieces have been accumulated previously before step 10 has been completed.

After step 10 was completed and when **PRINT** key was pressed, 5 pieces were still on the scale.

02:04PM	02-18-14
6.0 lb GR	
5.0 lb TA	
1.0 lb NT	
5 Pieces	
18 Total Pieces	

PEAK WEIGHT

Field	Time	Date	Gross	Tare	Net	Count1	Count2	Peak Wt
Visible	YES	YES	YES	YES	YES	NO	NO	YES
Top	2	2	6	8	10	0	0	14
Left	2	13	7	7	7	0	0	2



* See Section [2.14. Peak Weight](#) (in User Operation)

Container weighs 5.0 lb

Item(s) in container weighs 11.0lb

The peak weight applied to the scale to date was 18.0lb
Gross weight and occurred on 02-17-14 @ 01:04PM

02:04PM	02-18-14
16.0 lb GR	
5.0 lb TA	
11.0 lb NT	
18.0 lb Peak Weight 02-17-14 01:04PM	

Section 7: Service and Maintenance

7.1. Troubleshooting the Instrument

DISPLAY	SYMPTOM	RESOLUTION
ERROR	<ul style="list-style-type: none"> Possible bad battery or power loss Program error 	<ul style="list-style-type: none"> Replace the PCB. Replace Battery
No Display	No Power	<ul style="list-style-type: none"> Check AC Input Check battery voltage
Drifting/Unstable	<ul style="list-style-type: none"> Display changes at a rapid pace. Loss of Excitation voltage. 	<ul style="list-style-type: none"> Check for damaged load cell, load cell cables, or bad main PC. Measure the Excitation Voltage (5VDC) Use a Simulator to troubleshoot.

7.2. Battery Installation

STAINLESS STEEL INSTRUMENT

1. Unscrew the black plastic end caps.
2. Insert five (5) alkaline "D" cell batteries.

ABS INSTRUMENT

3. Unscrew the two large knurled screws on the back of the Instrument
4. Remove the battery cover.
5. Insert five (5) alkaline "D" cell batteries.

- ✓ Industrial 'D' size Energizer EN95 battery or equivalent is recommended for maximum operating time.
- ✓ Stainless Steel models should have special formed key washers installed for grounding.
- ✓ Four (4) screws fasten the back cover plate at the corners.

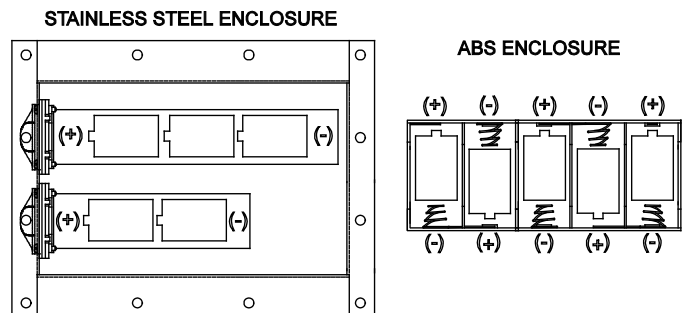

Appendix I: Data Output Formats

A. General Notes

- <CR>** = means carriage return character
<LF> = line feed character
<SP> = space character
<EOT> = end of transmission character
<...> = used to indicate individual characters for clarity only (not present in data stream)

B. Fairbanks/ Toledo Continuous Output

<STX><A><C><WWWWW><TTTTTT><CR>

- A** = Status Word A
B = Status Word B
C = Status Word C
W = Displayed Weight
T = Tare Weight

- ✓ Leading zeroes are not suppressed.
- ✓ The Continuous Computer Output is an uninitiated, unrequested output that is transmitted at a fixed time interval.



B. Fairbanks/ Toledo Continuous Output, Continued

Character String	Description
STX	Start of Text character : (02 Hex)
A	Status Word A
B	Status Word B
C	Status Word C
xxxxxx	Displayed Weight : x = Weight (6 characters if grad size does not have a decimal point.) (5 characters if the grad size does have a decimal point. The decimal point is not sent as part of the character string.
xxxxxx	Tare Value : x = Tare (6 characters if the grad size does not have a decimal point.) (5 characters if the grad size does have a decimal point. The decimal point is not sent as part of the character string
CR	Carriage Return Character : (0D hex)
CS	Checksum Character : If enabled, this character consists of the last eight bits of the binary sum of all characters transmitted up to this checksum character.

Status Word A

Bit #	Decimal Point or Zero Location							
	x00	x0	x	x.x	x.xx	x.xxx	x.xxxx	x.xxxxx
0	0	1	0	1	0	1	0	1
1	0	0	1	1	0	0	1	1
2	0	0	0	0	1	1	1	1
Increment Size								
Count by 1	Count by 2			Count by 5				
3	1	0			1			
4	0	1			1			
5	Always Logic 1							
6	Always Logic 0							
7	Parity Bit							

C. Cardinal 738 Continuous Scoreboard Output

<CR><P><WWWWW><m><SP><U><SP><g><SPSP><ETX>

W = Displayed weight

P = Polarity + = Positive weight
 - = Negative weight

U = Units

lb = pounds

kg = kilograms

m = Motion or o = Overload

g = Gross; n = Net

SP = Space

Leading zeroes are not suppressed

D. Weightronics WI-120 Continuous Output

<G><P><WWWWW><SP><U><CR><LF>

G = Gross; N = Net

P = Polarity + = positive weight
 - = negative weight

U = Units

lb = pounds

kg = kilograms

SP = Space

Leading zeroes are not suppressed

E. Condec Continuous Output

<STX><P><WWWWWW><U><G><M><CR>

P = Polarity space = positive weight

- = negative weight

W = Displayed weight

U = Units

L = pounds

K = kilograms

G = Gross; N = Net

M = Motion

Leading zeroes are suppressed

F. Demand Output - DEFAULT

Activated by the receipt of a <CR>.

Gross Weight – No Motion – decimal points included

<SP> <W> <W> <W> <W> <W> <W> <SP> <|> <SP> <SP> <G>
<R> <SP> <SP> <CR> <LF> <EOT>

Gross Weight – Motion – decimal points included

<SP> <W> <W> <W> <W> <W> <W> <SP> <|> <SP> <SP> <g>
<r> <SP> <SP> <CR> <LF> <EOT>

Net Weight – No Motion – decimal points included

<SP> <W> <W> <W> <W> <W> <W> <SP> <|> <SP> <SP> <N>
<T> <SP> <SP> <CR> <LF> <EOT>

G. Continuous Output - DEFAULT

- ✓ Outputs once every display update rate cycle.
- ✓ Continuous Output formatted output. Same for Poll and Auto
- ✓ Gross Weight – No Motion – decimal points included.

<SP> <W> <W> <W> <W> <W> <W> <SP> <|> <SP> <SP> <G>
<R> <SP> <SP> <CR> <LF> <EOT>

Gross Weight – Motion – decimal points included

<SP> <W> <W> <W> <W> <W> <W> <SP> <|> <SP> <SP> <g>
<r> <SP> <SP> <CR> <LF> <EOT>

Net Weight – No Motion – decimal points included

<SP> <W> <W> <W> <W> <W> <W> <SP> <|> <SP> <SP> <N>
<T> <SP> <SP> <CR> <LF> <EOT>

Net Weight – Motion – decimal points included

<SP> <W> <W> <W> <W> <W> <W> <SP> <|> <SP> <SP> <n>
<t> <SP> <SP> <CR> <LF> <EOT>

H. PLC (DO NOT USE)

The PLC selection is no longer functional within the PC2255 software and should not be used or selected.

General Information

The information below is automatically configured by the FB2255 and is provided as supplemental information only.

Baud Rate	19,200
Data Bits	8
Parity	None
Stop Bit	1
Mode	Continuous

- ✓ Continuous Output, transmitting data on every other A/D update.
 - Approximately 32 transmissions per second.

The output string is **12 characters**, seen as “**wwwwwwuumm<eot>**” where,

<wwwwwww> = Weight including decimal point and negative sign.

Negative sign precedes most significant digit and may be preceded by space characters.

<uu> = units “lb”, “kg”, “oz”, or “g”. “oz” may indicate ounces, or lb/ounces.

<mm> = mode “GR” or “NT” for stable weight, or “gr” or “nt” for motion.

<eot> = end of text.

Example 1: **Gross – lbs. – Weight Stable**

<WWWWWWW> <l> <G> <R> <EOT>

Example 2: **Gross – lbs. – Weight in Motion**

<WWWWWWW> <l> <g> <r><EOT>

Example 3: **Net – kgs. – Weight Stable**

<WWWWWWW> <k> <g> <N> <T> <EOT>

Example 4: **Net – kgs. – Weight in Motion**

<WWWWWWW> <k> <g> <n> <t> <EOT>

NOTE: Once **FIELD BUS CONFIGURATION** has been programmed, the installing technician’s setup is complete.

Specialized tools available from: <https://www.anybus.com/support/file-doc-downloads/anybus-compactcom-30-series>

Interface of the **HMS COMMUNICATIONS** device, power supply to same device, and programming of the PLC is strictly the responsibility of the customer.



I. UPS

- ✓ **Serial Data Output Format** for **UPS Worldship Software**.

The instrument will transmit the following string of data.

Character Number 1 2 3 4 5 6 7 8 9 10 11 12 13 14 15 16 17 18

String 1

Gross Weight: X X X X . X X SP l/k b/g SP G/g R/r SP SP CR LF EOT

NOTES:

- ✓ Characters denoted by “**X**” are characters **0-9**.
 - Leading zeroes are replaced with spaces (**SP**).
 - **Character 5** is a decimal point (**HEX 2E**).
 - ✓ Lower case “**l**” and “**b**” for **Avoirdupois Units**, or “**k**” and “**g**” for **Metrics Units**.
 - ✓ The first weight character will be a **minus (-)**, **HEX 2D**, If weight is negative.
 - ✓ Characters separated with a “**/**” denoted one of the characters will be transmitted.
 - Lower case **gr** in **characters 12** and **13** indicates scale motion.
 - Upper case indicates stable weight.
 - ✓ **EOT, HEX 04** is transmitted in “**HiCAP**” condition.
 - ✓ Transmission will occur when a **CR (Hex 0D)** carriage return is received.
-



J. P Ship

- ✓ Serial Data Output Format for P Ship, used to interface to FedEx Shipping Programs.
- ✓ All computer commands and scale responses are **ASCII Character Strings**, where:

<CR> is an ASCII carriage return (hexadecimal 0D)

<LF> is an ASCII line feed (hexadecimal 0A)

<ETX> is an ASCII End-Of-Text (hexadecimal 03)

(STATUS) is a two ASCII number representation of the scale status (in the form of hexadecimal 3x3x, where the bit pattern of the low nibbles, indicated by an "x", determine the actual status conditions)

COMPUTER RESPONSE	SCALE RESPONSE	COMMAND RESULT
W<CR>	<LF><SP>XXX.XXUU<CR>(STATUS)<ETX>	Returns the weight and scale status in two ASCII digits.
S<CR>	<LF>S(STATUS)<CR><ETX>	Returns the scale Status in two ASCII digits (defined in the following section)
Z<CR>	No response	Zeroes the scale
All Else	<LF>?<CR>	Unrecognizable command

Notes: In the scale response to "W<CR>":

- XXX.XX** = A five digit number with two digits to the right of the decimal point which is the displayed scale weight.
- SP** = An ASCII space (hexadecimal 20). In the event of a negative weight, an ASCII, "-" (hexadecimal 2D) is returned in this location.

J. P Ship, Continued

3. **UU** = A two character weight identifier. If the scale is configured to weigh kilograms, a "KG" (uppercase letters) will be returned, if configured for pounds, "LB" (uppercase letters) will be returned.

4. The decimal point is returned by the scale as part of the ASCII string.

5. Interpretation of scale status digits

The high order nibble of each status byte has a value of 3 (0011 B). The low order nibble of the first and second bytes are defined as follows:

1st Byte: Bit 0 - High = scale is in motion
Low = scale is stable
Bit 1 - High = scale at zero
Low = scale not at zero
Bit 2 - Low = not used
Bit 3 - Low = not used

2nd Byte: Bit 0 - High = scale is below zero
Low = scale is not below zero
Bit 1 - High = scale is over capacity
Low = scale is not over capacity
Bit 2 - High = scale ROM program failure
Low = scale ROM okay
Bit 3 - High = faulty calibration data*
Low = scale calibration okay

*This is the result of an incorrect checksum

An example of the scale response to an "S" command would be:

<LF>S20<CR><ETX>

The following status conditions are in effect for this response:

- scale at zero
- scale is not below zero
- scale is not over capacity
- scale ROM okay
- scale calibration okay

Appendix II: Remote PC Commands

Transmitting certain ASCII characters to the FB2255 will duplicate a key-press from a remote location via the RS 232 serial connection to Port 1. The baud rate, parity, and stop bits must match. The data bit length is 8 bits.

ASCII CHARACTER	FUNCTION PERFORMED / COMMENTS
Z (upper case)	Zero. Active in the Polled or Button Modes
A (upper case)	Tare (Auto Tare). Active in the Polled or Button Modes
U (upper case)	Change Units. Active in the Polled or Button Modes
g (lower case)	Toggle Gross / Net. Active in the Polled or Button Modes
P or p (either case)	'P' or 'p". Active in the Polled or Button Modes The output will be the same as if the instrument front panel switch is operated. This output is formatted via the PC2255 program, using the 'Format Ticket' tab and can include any of the field items and in the order prescribed.
CR (upper case)	Carriage Return. Active in the Polled Mode Output will be the displayed weight, either Net or Gross. If Motion then "GR" and "NT" are transmitted as "gr" and "nt". Both strings are terminated with; Carriage Return, Line Feed, End Of Transmission, <CR><LF><EOT>



EXAMPLE

"12345 lb GR<CR><LF><EOT>" or "12345 lb nt<CR><LF><EOT>".

c (lower case) Active in the Polled or Continuous Modes If the instrument is in the Polled Mode the output will be the same as if a Carriage Return was received. The output will be transmitted when the display is refreshed. If the instrument is in the Continuous Mode the output will be transmitted immediately regardless of display update timing.

NOTE: *The programmed parameters in the FB2255 apply equally to both a key press and a remote PC command.*

*For example, in order to change the **Units option** for more than one unit, it must be **Enabled**.*

Appendix III: FB2255 Remote Display Wiring

RS232 INTERFACE WIRING (Master)				FB2250/55 REMOTE DISPLAY			FB2250* REMOTE DISPLAY		
MODEL	COM	CONNECT		COM	CONNECT		COM	CONNECT	
FB2200 (ABS)	1	3	TX	1	TB4(A)-1	RX	1	TB4-1	RX
	1	5	GND	1	TB4(A)-4	GND	1	TB4-4	GND
FB2200 (SS)	1	3	TX	1	TB4(A)-1	RX	1	TB4-1	RX
	1	5	GND	1	TB4(A)-4	GND	1	TB4-4	GND
FB2255 or FB2250	1	TB4(A)-2	TX	1	TB4(A)-1	RX	1	TB4-1	RX
	1	TB4(A)-1	RX	1	TB4(A)-2	TX	1	TB4-2	TX
	1	TB4(A)-4	GND	1	TB4(A)-4	GND	1	TB4-4	GND
	2	TB4(B)-2	TX	1	TB4(A)-1	RX	1	TB4-1	RX
	2	TB4(B)-1	RX	1	TB4(A)-2	TX	1	TB4-2	TX
	2	TB4(B)-4	GND	1	TB4(A)-4	GND	1	TB4-4	GND
FB2250*	1	TB4-2	TX	1	TB4(A)-1	RX	1	TB4-1	RX
	1	TB4-1	RX	1	TB4(A)-2	TX	1	TB4-2	TX
	1	TB4-4	GND	1	TB4(A)-4	GND	1	TB4-4	GND
	2	TB4-7	TX	1	TB4(A)-1	RX	1	TB4-1	RX
	2	TB4-6	RX	1	TB4(A)-2	TX	1	TB4-2	TX
	2	TB4-9	GND	1	TB4(A)-4	GND	1	TB4-4	GND
2300	1	TB4-1	TX	1	TB4(A)-1	RX	1	TB4-1	RX
	1	TB4-2	GND	1	TB4(A)-4	GND	1	TB4-4	GND
2500	2, 3, 4 or 5	3	TX	1	TB4(A)-1	RX	1	TB4-1	RX
		5	GND	1	TB4(A)-4	GND	1	TB4-4	GND
2500 (SS)	2, 3, 4 or 5	4	TX	1	TB4(A)-1	RX	1	TB4-1	RX
		8	GND	1	TB4(A)-4	GND	1	TB4-4	GND
2800	A	TB3-2	TX	1	TB4(A)-1	RX	1	TB4-1	RX
		TB3-4	GND	1	TB4(A)-4	GND	1	TB4-4	GND
	B	TB2-2	TX	1	TB4(A)-1	RX	1	TB4-1	RX
		TB2-4	GND	1	TB4(A)-4	GND	1	TB4-4	GND
5200A	1 or 2	4	TX	1	TB4(A)-1	RX	1	TB4-1	RX
		5	RX	1	TB4(A)-2	TX	1	TB4-2	TX
		8	GND	1	TB4(A)-4	GND	1	TB4-4	GND

* Old style with 28600 Main PCB.

Appendix VI: FB2255 Remote Display Active Keys

MODEL	ZERO	UNIT	GROSS/NET	AUTO TARE	PRINT
FB2200	***	***	***	***	***
FB2250	Y	Y	Y	Y	Y
FB2255	Y	Y	Y	Y	Y
2300	***	***	***	***	***
2500/FB2550	***	***	***	***	***
2800	***	***	***	***	***
5200A	***	Y	Y	***	***

Appendix VII: FB2255 Panel Mount dimensions

Panel Mount cutout dimensions are 11.0" x 9.0" x 3.25" minimum.

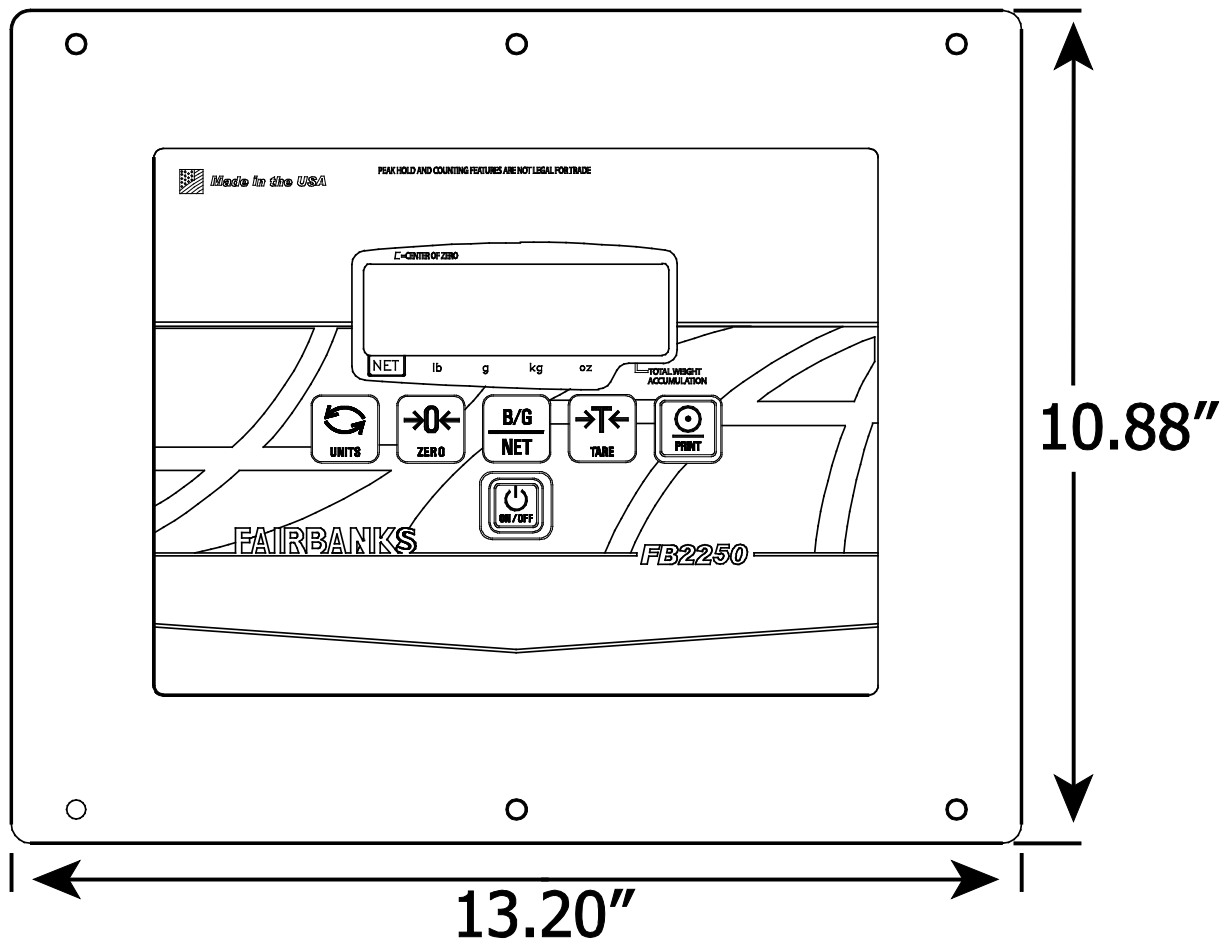



Fairbanks Scales Inc.
www.fairbanks.com

FB2255 Series Instrument

**FB2255/ PC2255
Document 51297**