

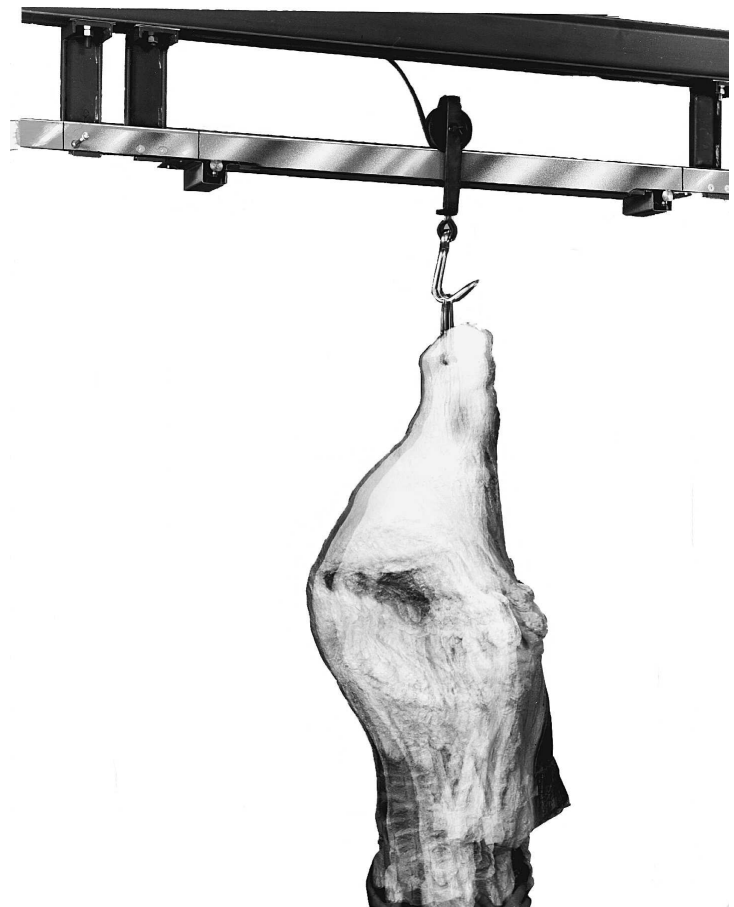

---

# 5260 Series Unirail



# Amendment Record

5260 Series Unirail

50019 / SJ3708

Manufactured by Fairbanks Scales Inc.  
821 Locust  
Kansas City, Missouri 64106

Issue #1		New Product	Revision A
Issue #2		Revision B	
Issue #3		Revision C	
Issue #4		Revision D	
Issue #5	05/85	Revision E	
Issue #6	07/03	Updated layout, models, part numbers, and drawings	
Issue #7	01/06	Revised Parts specific to model (page 18)	
Revision 8	03/12	Corrected part numbers on part list.	

Every effort has been made to provide complete and accurate information in this manual. However, although this manual may include a specifically identified warranty notice for the product, Fairbanks Scales makes no representations or warranties with respect to the contents of this manual, and reserves the right to make changes to this manual without notice when and as improvements are made.



# Table of Contents

## **Section 1: *General Information***

- A. Introduction . . . . . 4
- B. Specifications and Requirements . . . . . 4

## **Section 2: *Installation***

- A. General Service Policy . . . . . 6
- B. Overview . . . . . 6
- C. Pre-Installation Checklist . . . . . 7
- D. Unpacking . . . . . 8
- E. Safety . . . . . 8
- F. Installation Overview . . . . . 9
- G. Wiring . . . . . 11

## **Section 3: *Calibration***

- A. Calibration Procedure . . . . . 12

## **Section 4: *Operation***

- A. Scale Operation Instructions . . . . . 13

## **Section 5: *Service and Maintenance***

- A Introduction . . . . . 14
- B. Replacement and Alignment Procedures . . . . . 14

## **Section 6: *Parts List* . . . . . 16**

# Section 1: General Information

## A. Introduction

The Unirail is an electronic weighing device designed for use with existing overhead monorail systems in the meat processing industry. The scale is constructed of Type 304 stainless steel. It is fully electronic in design with the live rail supported at each end by a strain gauge loadcell. The scale meets the criteria for both NIST Handbook 44 and USDA Packers & Stockyards Administration requirements, but is not NTEP approved. Read these instructions carefully before installing and operating this scale.

## B. Specifications and Requirements

---

<b>Capacity:</b>	1,500 lbs X .5 lbs (1)
<b>Minimum Graduation:</b>	.5 lb (2)
<b>Minimum Tare:</b>	.1 lb (2)(3)



### Note:

- (1) Do not exceed single cell load of 1250 lbs.
- (2) Equivalent to the weight indicators capability. Other combinations subject to special inquiry.
- (3) All monorail scales operated under USDA jurisdiction are required to have tare settings to 0.1 lbs.

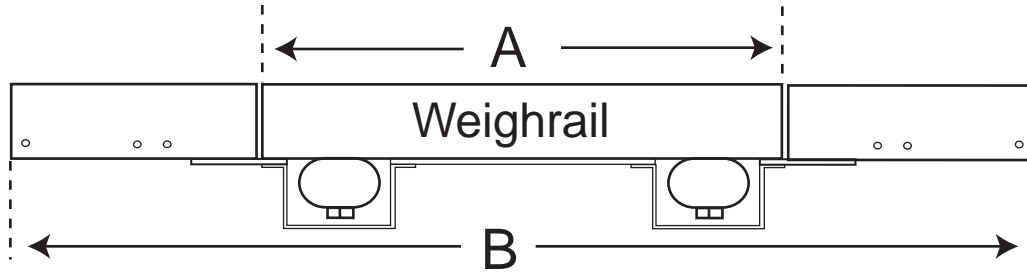

**Length:**

<b>Model</b>	<b>A: Weigh Rail Length</b>	<b>B: Overall Length</b>
H21-5260-A	22 11/16"	34"
H21-5260-B	28 11/16"	40 3/16"
H21-5260-C	34 11/16"	46 3/16"
H21-5260-D	40 11/16"	52 3/16"
H21-5260	54 11/16"	66 3/16"

## Section 2: Installation

### A. General Service Policy

Prior to installation, it must be verified that the equipment will satisfy the customer's requirements as supplied, and as described in this manual. If the equipment cannot satisfy the application and the application cannot be modified to meet the design parameters of the equipment, the installation should not be attempted.

### B. Overview

1. These instructions apply to the Unirail only; installation procedures for the Digital Weight Indicator and any other peripherals are given in manuals specifically provided for those units. The instructions include a pre-installation checkout, which must be performed before the equipment is placed in service.

2. All electronic and mechanical calibrations and or adjustments required to make this equipment perform to accuracy and operational specifications are considered to be part of the installation, and are included in the installation charge. Only those charges which are incurred as a result of the equipment's inability to be adjusted or calibrated to performance specifications may be charged to warranty.

3. Absolutely no physical or electrical modifications are to be made to this equipment. Electrical connections other than those specified may not be performed, and no physical alterations (mounting holes, etc.) are permitted.

4. The installing technician is responsible to make certain that personnel are fully trained and familiar with the capabilities and limitations of the equipment before the installation is considered complete.

The complete installation consists of:

1. Verifying the application
2. Unpacking
3. Inspection

4. Customer and site readiness:
  - a. Is the Location ready?
  - b. Is the customer aware there will be work disruptions?
  - c. Are the operators available for training?
5. Installation of the Unirail (See Note).
6. Installation of the digital weight indicator.
7. Calibration and Adjustments
8. Customer training



**Note:**

*Rail hangers, mounting hardware, and any further supports are not provided. The weight of the Unirail varies from 95 lbs to 150 lbs.*

---

**C.**  
**Pre-Installation  
Checklist**

The following points should be checked and discussed with the Area Sales Manager, Area Service Manager, and/or customer, if necessary, before the technician goes to the site to install the equipment.

1. Has the customer's application been checked to make certain that it is within the capabilities and design parameters of the equipment?
2. If the installation will disrupt the customer's normal operations, is he aware and has he made arrangements?
3. Is properly-grounded AC power available at the installation location?
4. Has the service technician thoroughly reviewed the installation procedures?
5. Who is providing the exact location and opening in the overhead monorail? Will they be there?
6. Who is providing the rail hangers, mounting hardware, and any other supports? Will they be there?



7. Who is providing assistance to lift and fasten the Unirail onto the rail hangers? Will they be there?

8. Has the service technician reviewed the recommended set-up with the Area Sales Manager or Area Service Manager, and identified all necessary variations to satisfy the customer's particular Application?

9. Will the equipment operator(s) be available for training?

---

**D.**  
**Unpacking**

1. Check that all components are on hand, and agree with the customer's order.

2. Remove the Unirail from its packing material, checking to make certain that all parts are accounted for and no parts are damaged. Advise the shipper immediately if damage has occurred. Order any parts necessary to replace those which have been damaged. Keep the shipping container and packing material for future use. Check the packing list.

3. Collect all necessary installation manuals for the instrument and accessories.

4. Perform an inspection, making certain that all hardware and electrical connections are secure.

---

**E.**  
**Safety**

As is the case with any material handling equipment, certain safety precautions should be observed during operation:

1. Never load the Unirail beyond its rated capacity. Refer to the rating on the serial number plate if in doubt.

2. Ensure that the structure which supports the Unirail is capable of withstanding the weight of the Unirail plus its rated capacity load.

3. Do not load the Unirail if there is any evidence of damage to it or its supporting structure.

---

## F.

### Installation Instructions Overview

The weigh rail, its approaches, the load cells, and their housing are arranged in a configuration that requires no space above the customer's normal supporting structure. All components of the Unirail are assembled as one complete calibrated unit ready for installation into the existing monorail line. Install the Unirail at the approach rails by direct attachment to the rail hangers. The scale should be installed level in both directions in the horizontal plane. If level condition along the rail cannot be obtained, out of level must not exceed 0.6 degrees, for 0.5 feet on the length of the weigh rail. There is no welding required to install the scale. If any welding is required on any adjacent structure, perform the welding prior to scale installation. If welding is required after installation, the entire scale assembly, live and adjacent dead rails, should be physically removed prior to welding to avoid possible damage to the load cells.



**Warning**



#### **WARNING:**

*DO NOT weld on the scale structure or damage to the load cells may occur.*

#### **Note:**

*Use cast or fabricated steel hangers to support the scale structure. Do not use light gauge (cold formed) steel hangers.*

STANDARD RAIL HANGERS  
AT EACH END - NOT INCLUDED  
SEE NOTE BELOW

## FRONT VIEW

LOCATE HANGERS TO SUIT HOLES  
IN EACH APPROACH RAIL EACH END

NOTE:  
WEIGH RAIL IS FACTORY ADJUSTED 1/32" HIGH  
TO ACCOUNT FOR LOAD CELL DEFLECTION

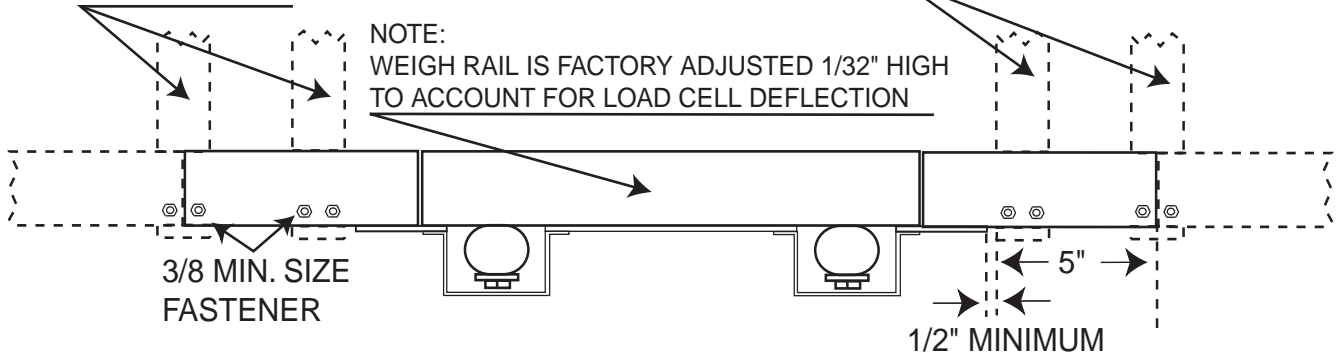

APPROACH RAIL

## REAR VIEW

3/32 GAP

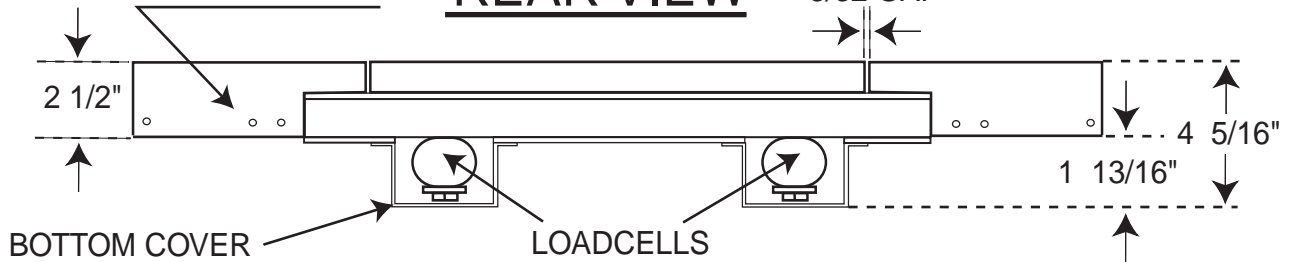

## TOP VIEW

SCALE FRAME ASSY

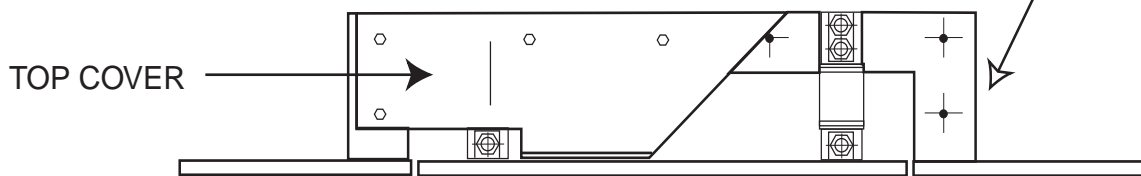

## APPROACH RAIL VIEW

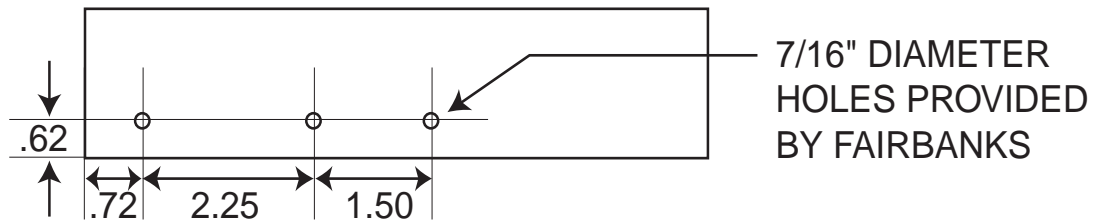

ALL DIMMENSIONS SHOWN IN INCHES.

# G.

## Wiring

After the Unirail is physically installed, install the digital weight indicator per the appropriate service manual.

1. Attach the cable from the Unirail splice tube to the weight indicator as follows:

Cable leads

Green	+ Excitation
Black	- Excitation
White	+ Signal
Red	- Signal
Shield	

2. Attach a length of 18 gauge wire from the scale structure to a suitable ground.

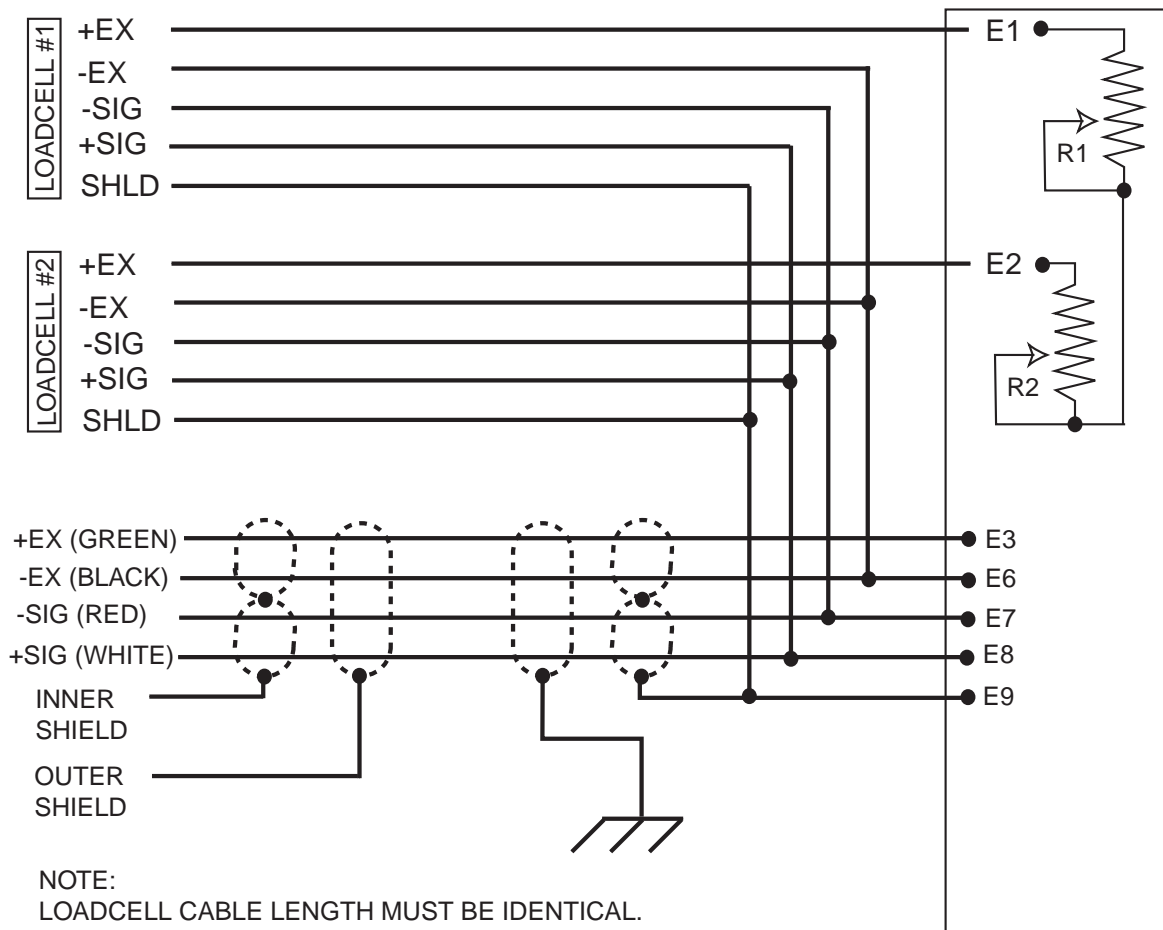

## Section 3: Calibration

### A. Calibration Procedure

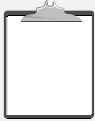

The Unirail contains two (2) potentiometers located in a sealed flexible tube inside the frame. These are used to adjust the weight indication of an individual loadcell, to enable the Unirail to display the same weight at each end of its weigh rail. Testing should be performed using 500 lbs suspended on a single roller hook. The hook is then moved from load cell No. 1 and No. 2, and the weight indications are noted and compared. A properly adjusted Unirail will have a maximum difference of  $\frac{1}{2}$  lb between opposite ends with a 500 lb load.

**Note:**

*The adjustment is intended to achieve equal readings, which may not necessarily be correct and accurate. When complete, final calibration is performed with the digital weight indicator.*

## **Section 4: Operation**

**A.**

### **Scale Operation Instructions**

1. Weigh empty roller and enter tare on instrument.
2. Set in NET position.
3. Roll onto the live section of the rail one or more sections of meat supported from roller hooks.
4. The weight is now taken in the static mode.
5. Repeat steps 2-4 for further weighments; step 1 if different roller is used.

## Section 5: Service and Maintenance

### A. Introduction

The weigh rail should remain in the center of its fixed approaches, and free to move up and down very slightly on its load cell mounts. The weigh rail must remain free and unobstructed for proper performance. Periodic examination and cleaning any debris from its gaps should be performed regularly. Do not lubricate, grease, or oil any part of the Unirail.

### B. Replacement & Alignment Procedures

---

#### Loadcells & Weighrail:

1. Load cells for the Unirail are provided in matched pairs, and are always replaced as a set. Electrical connections are intended to be individually soldered and insulated, and re-installed in the splice tube. Note wiring connections before disconnecting them, and removing the weighrail and loadcells.
2. Mount the replacement load cells to the support bar with existing 1/2-20 cap screws. Tighten finger tight.
3. Mount the weighrail to the cells using the load cell mounting tool pn 95272. The tool is effectively a threaded stud having a shaft diameter equal to the hole in the load cell. It centers the rail for optimum clearance. Equally space the weighrail between the approach rails, then tighten the load cell support screws.
4. Torque the cell support screws to approximately 75 ft lbs.
5. Remove the Unirail load cell fixture screws supporting the weighrail to the load cells, and replace them with the special studs. Use the stud locking compound. Remove the weighrail and torque the studs to approximately 75 ft lbs.

6. Using a 3/4" end wrench turn the elastic stop nuts onto the studs until they are just tight against the rail, then back off ¼ turn so the weighrail is just free to move. (This adjustment is critical to proper scale performance.) The weighrail now floats between the dead rails and prevents binding and torque on the load cells when the load is applied.

Since the entire scale becomes an integral part of the overall monorail system, normal deflection of the system will not affect scale accuracy - that is, the scale moves with adjacent rail, not in opposition to it, as there is no differential movement. However, the design of a safe, stable, supporting structure adjacent to the scale is essential and is the responsibility of the customer.



## Section 6: Parts List

### PARTS COMMON TO ALL MODELS

ITEM #	Part #	DESCRIPTION
3	12226	Loadcells - Matched Pair <sup>(1)</sup>
5	11586	Shim - Weighrail
6	11936	Stud - Rail
7	11926	Adhesive - Stud Lock
8	11179	Nut - Hex - Stop - 1/2-20
9	11067	Screw - Cap - Hex Hd - 1/2-20 X 2 1/2"
10	14774	Block - Loadcell
11	11585	Shim - Loadcell
12	11073	Screw - Cap - Hex Hd - 10-24 X 2"
13	11099	Nut - Hex - 10-24
14	11022	Bushing - Strain Relief
16	11353	Wire - Hook-up - PVC - 18 AWG
17	11638	Splice Assy, Balance Potentiometers <sup>(2)</sup>
18	11332	Stopper, 2 Holes
19	12053	Stopper, No Holes
20	11330	Stopper, 1 Hole
21	11328	Clamp - Hose
22	11266	Clip, Cable
23	11324	Pipe - Flexible
	95272	Tool, Loadcell Mount Fixture

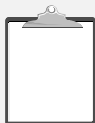

#### Note:

(1) Load cells for the Unirail are provided in matched pairs, and are replaced as a set. NEVER cut the loadcell cable provided with the cells.

(2) includes flexible pipe, stoppers, clamps, splice tube cable assy, 18 Ft Interface cable, and PCB Assy, Balance, Pots, (11630)

### PARTS SPECIFIC TO MODEL:

KEY	DESCRIPTION	5260-A (18")	5260-B (24")	5260-C (30")	5260-D (36")	5260 (50")
1	Weighrail	19108	19217	19293	19318	11582
2	Frame	19106	19212	19292	19317	11581
4	Bottom Cover	19110	19215	19294	19320	11584
15	Top Cover	19112	19222	19295	19319	11583

FRONT VIEW

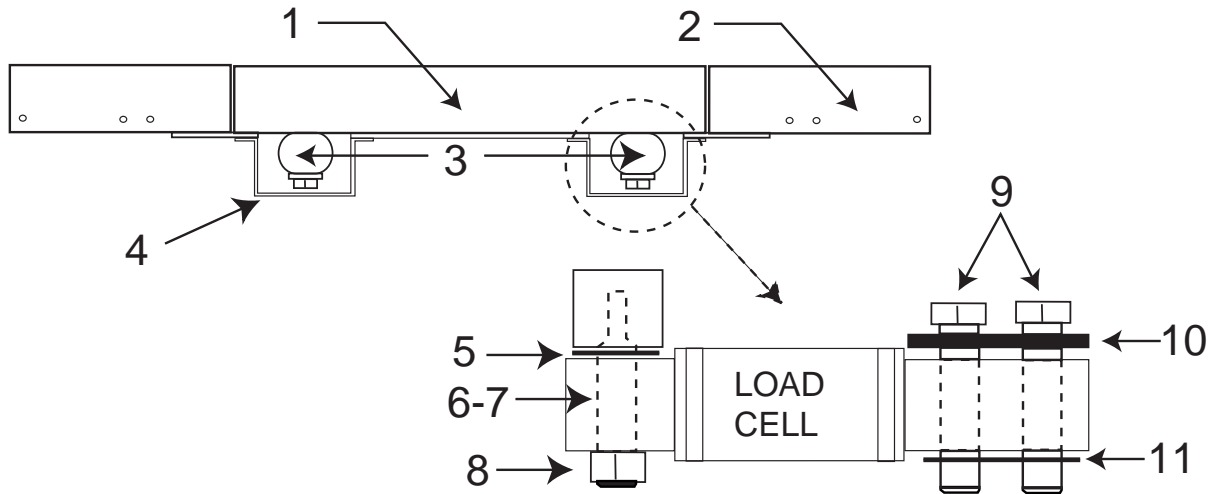

TOP VIEW

