

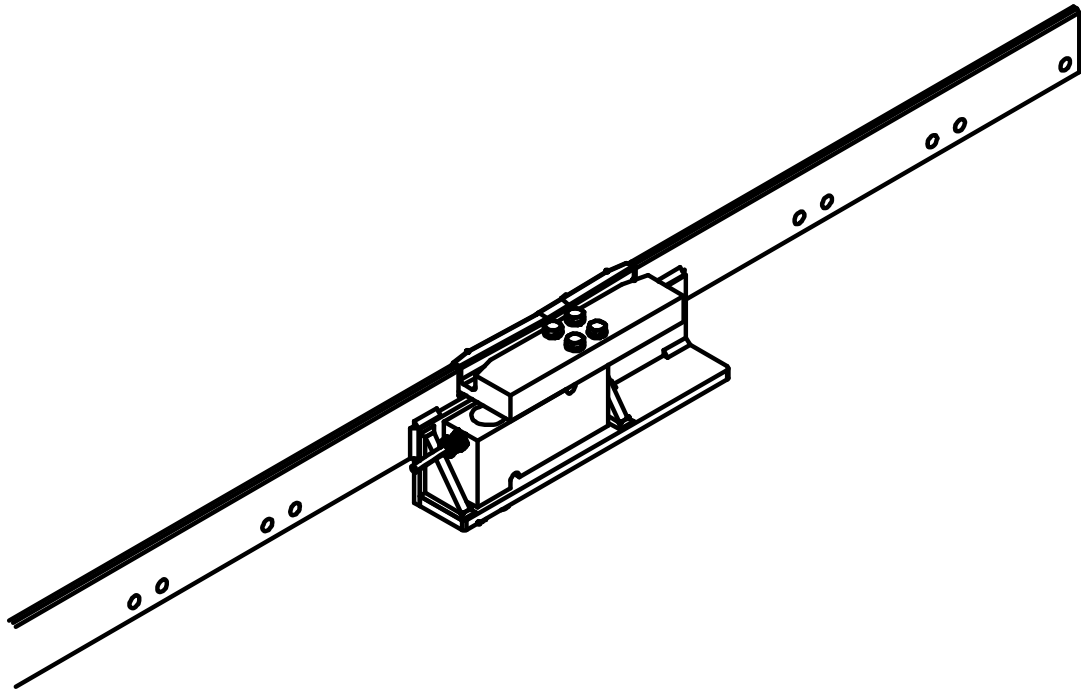

Installation Manual

# 5270 Series Monorail Scale



# **AMENDMENT RECORD**

## **5270 Series Monorail Scale Document 51439**

Manufactured by **Fairbanks Scales Inc.**  
821 Locust  
Kansas City, Missouri 64106

Created	12/2018	
Revision 1	12/2018	Released document.



## **Disclaimer**

Every effort has been made to provide complete and accurate information in this manual. However, although this manual may include a specifically identified warranty notice for the product, Fairbanks Scales makes no representations or warranties with respect to the contents of this manual, and reserves the right to make changes to this manual without notice when and as improvements are made.

It is the responsibility of the requesting party to develop, maintain, install, and connect networking devices and general network connectivity as it applies to the originating party's network. No warranty or guarantee, expressed or implied, concerning the network, its design, its installation, or operational characteristics has been offered by Fairbanks Scales. Fairbanks Scales shall not be liable for any loss, damage, cost of repairs, incidental or consequential damages of any kind, whether or not based on express or implied warranty, contract, negligence, or strict liability arising in connection with the design, development, installation, or use of an intended network.

## **Trademarks**

All other product names mentioned herein are used for identification purpose only and may be trademarks and/or registered trademarks of their respective companies.

### **© Copyright 2018**

This document contains proprietary information protected by copyright. All rights are reserved; no part of this manual may be reproduced, copied, translated, or transmitted in any form or by any means without prior written permission of the manufacturer.

---

# Table of Contents

---

<b>SECTION 1: GENERAL INFORMATION .....</b>	<b>5</b>
<b>1.1. Introduction .....</b>	<b>5</b>
<b>1.2. Specifications .....</b>	<b>5</b>
1.2.1. <i>Monorail Scale Specifications .....</i>	<i>5</i>
1.2.2. <i>Load Cell Specifications .....</i>	<i>6</i>
<b>SECTION 2: COMPANY SERVICE INFORMATION .....</b>	<b>7</b>
<b>2.1. General Service Policy.....</b>	<b>7</b>
<b>2.2. Users' Responsibilities.....</b>	<b>8</b>
<b>SECTION 3: INSTALLATION &amp; OPERATION .....</b>	<b>9</b>
<b>3.1. Installation .....</b>	<b>9</b>
3.1.1. <i>Overview.....</i>	<i>9</i>
3.1.2. <i>Pre-Installation Checklist .....</i>	<i>9</i>
3.1.3. <i>Unpacking.....</i>	<i>10</i>
3.1.4. <i>Safety.....</i>	<i>10</i>
3.1.5. <i>Standard Installation .....</i>	<i>11</i>
3.1.6. <i>Wiring.....</i>	<i>13</i>
<b>3.2. Operation .....</b>	<b>13</b>
3.2.1. <i>Scale Operation Instructions.....</i>	<i>13</i>
<b>SECTION 4: SERVICE &amp; MAINTENANCE .....</b>	<b>14</b>
<b>4.1. Introduction .....</b>	<b>14</b>
<b>4.2. Replacement &amp; Alignment Procedures .....</b>	<b>14</b>
4.2.1. <i>Replacing the Loadcell .....</i>	<i>14</i>
<b>SECTION 5: PARTS .....</b>	<b>15</b>

---

# Section 1: General Information

---

## 1.1. Introduction

The 5270 Series is an electronic weighing device designed for use with existing overhead monorail systems in the meat processing industry. The scale is constructed from stainless steel. It is fully electronic in design utilizing a single-point, stainless steel IP69k loadcell. The scale meets the criteria for both NIST Handbook 44 and USDA Packers & Stockyards Administration requirements and it is designed to meet NTEP and MC standards (approval pending). Read these instructions carefully before installing and operating this scale.

## 1.2. Specifications

### 1.2.1. Monorail Scale Specifications

Capacity	<b>1,000 lbs</b>
Minimum Graduation	<b>0.5 lbs</b>
Minimum Tare	<b>0.1 lbs (1)(2)</b>
Operating Temperature	<b>14°F to 104°F; -10°C to +40°C</b>
Overload	<b>150% of capacity</b>
Approvals	<b>NTEP: 2000d (pending)</b> <b>MC 2000d (pending)</b>

(1)Equivalent to the weight indicators capability. Other combinations subject to special inquiry.

(2)All monorail scales operated under USDA jurisdiction are required to have tare settings to 0.1 lbs.

---

**NOTE:** Rail hangers, mounting hardware, and any further supports are not provided. The weight of the **5270 Series** is approximately 70 pounds.

---

### 1.2.2. Load Cell Specifications

Capacity	<b>500 kg</b>
Rated output	<b>2.0 ± 0.2mV/V</b>
Bridge Resistance	<b>415 Ω ± 15 Ω input, 350 Ω ± 3 Ω output</b>
Safe Overload	<b>150% of FS</b>
Seal	<b>IP68/69K</b>

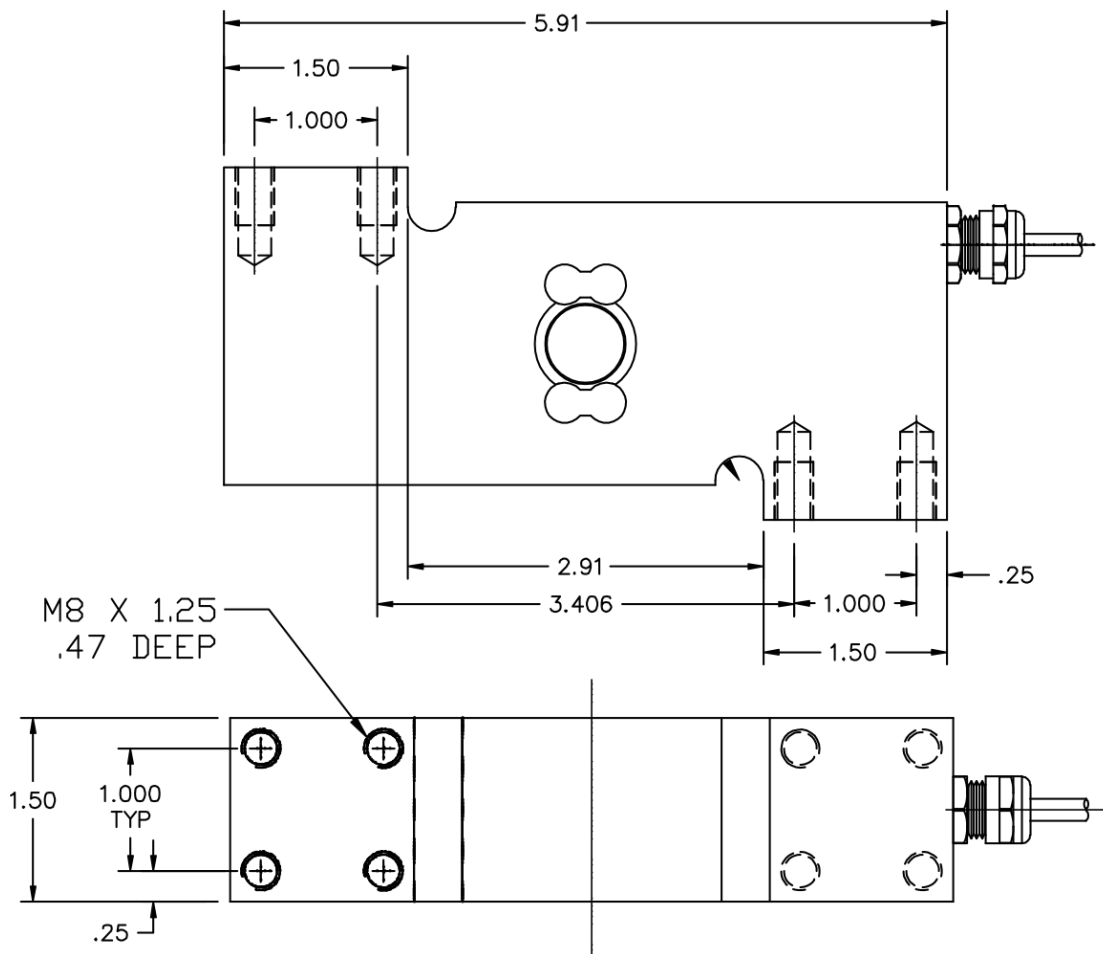

**NOTE: All dimensions are in inches**

---

## Section 2: Company Service Information

---

### 2.1. General Service Policy

***Prior to installation, always verify that the equipment satisfies the customer's requirements as supplied, and as described in this manual.***

- If the equipment cannot satisfy the application and the application cannot be modified to meet the design parameters of the equipment, **the installation should NOT be attempted.**
- Instructions within this manual apply to the instrument and its specific accessories. Installation procedures for printers and other peripherals are given in manuals specifically provided for those units. The instructions include a pre-installation checkout which must be performed either at the service center before the technician goes to the site, or at the site before he places the equipment in service.
- All electronic and mechanical calibrations and/or adjustments required to make this equipment perform to accuracy and operational specifications are considered to be part of the installation, and are included in the installation charge. **Only those charges which are incurred as a result of the equipment's inability to be adjusted or calibrated to performance specifications may be charged to warranty.**
- Absolutely no physical, electrical, or program modifications other than selection of standard options and accessories are to be made to this equipment. Electrical connections other than those specified may not be performed, and no physical alterations (mounting holes, etc.) are allowed and will immediately void warranty

***All load cells, load cell cables, and all interconnecting cables used for the scale components must be located a minimum of thirty-six inches (36") away from all single and multiple phase high energy circuits and electric current-carrying conductors.***

- This includes, but is not limited to **digital weight instruments, junction boxes, sectional controllers, and power supplies.**
- This includes any peripheral devices, such as **printers, remote displays, relay boxes, remote terminals, card readers, and auxiliary data entry devices.**
- Scale components themselves must also be at least **thirty-six inches (36") away** from other high energy components, including the following devices.  
Any machinery with outputs of **120, 240, or 480 volts AC.**  
High voltage wiring runs and stations, AC power transformers, overhead or buried cables, electric distribution panels, electric motors, florescent and high intensity lighting which utilize ballast assemblies, electric heating equipment, traffic light wiring and power, and all relay boxes.
- Scale components are not designed to operate on internal combustion engine driven electric generators and other similar equipment.  
This includes all digital weight Instruments and peripheral devices.
- Electric arc welding can severely damage scale components, such as digital weight Instruments, junction boxes, sectional controllers, power supplies, and load cells.

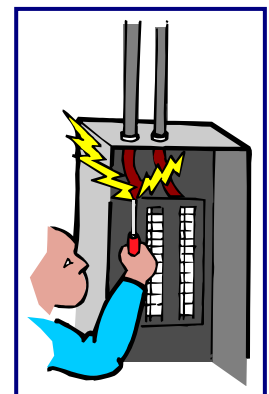

*The Service Technician's responsibility that all personnel are fully trained and familiar with the equipment's capabilities and limitations before the installation is considered complete.*

**WARNING!**

Absolutely no physical, electrical or program modifications other than selection of standard options and accessories can be made by customers to this equipment

Repairs are performed by Fairbanks Scales Service Technicians and Authorized Distributor Personnel ONLY!

*Failure to comply with this policy voids all implied and/or written warranties*

**Please contact your local  
FAIRBANKS SCALES REPRESENTATIVE  
<https://www.fairbanks.com/service/locations.cfm>  
for any questions, problems, or comments.**

## 2.2. Users' Responsibilities

- ✓ All electronic and mechanical calibrations and/or adjustments required for making this equipment perform to accuracy and operational specifications should be performed by *trained service personnel*.
- ✓ Absolutely no physical, electrical or program modifications other than selection of standard options and accessories are to be made to this equipment.
- ✓ Electrical connections other than those specified may not be performed
- ✓ Physical alterations, such as holes, etc., are not allowed.

**Please contact your local  
FAIRBANKS SCALES REPRESENTATIVE  
<https://www.fairbanks.com/service/locations.cfm>  
for any questions, problems, or comments.**



---

## **Section 3: Installation & Operation**

---

### **3.1. Installation**

#### **3.1.1. Overview**

These instructions apply to the 5270 Series only; installation procedures for the instrumentation and any other peripherals are given in manuals specifically provided for those units. The instructions include a pre-installation checkout, which must be performed before the equipment is placed in service.

- All electronic and mechanical calibrations and or adjustments required to make this equipment perform to accuracy and operational specifications are considered to be part of the installation and are included in the installation charge. Only those charges which are incurred as a result of the equipment's inability to be adjusted or calibrated to performance specifications may be charged to warranty.
- Absolutely no physical or electrical modifications are to be made to this equipment. Electrical connections other than those specified may not be performed, and no physical alterations (mounting holes, etc.) are permitted.
- The installing technician is responsible to make certain that personnel are fully trained and familiar with the capabilities and limitations of the equipment before the installation is considered complete.

*These steps outline the standard installation for the **Monorail Scale**.*

1. Pre-installation check list
2. Unpacking
3. Safety
4. Standard Installation
5. Wiring
6. Operation

#### **3.1.2. Pre-Installation Checklist**

The following points should be checked and discussed with the Area Sales Manager, Area Service Manager, and/or customer, if necessary, before the technician goes to the site to install the equipment.

- Has the customer's application been checked to make certain that it is within the capabilities and design parameters of the equipment?

- If the installation will disrupt the customer's normal operations, have they made alternate arrangements?
- Is properly-grounded AC power available at the installation location?
- Has the service technician thoroughly reviewed the installation procedures?
- Who is providing the exact location and opening in the overhead monorail? Will they be there?
- Who is providing the rail hangers, mounting hardware, and any other supports? Will they be there?
- Who is providing assistance to lift and fasten the Unirail onto the rail hangers? Will they be there?
- Has the service technician reviewed the recommended set-up with the Area Sales Manager or Area Service Manager, and identified all necessary variations to satisfy the customer's application?
- Will the equipment operator(s) be available for training?

### ***3.1.3. Unpacking***

- Check that all components are on hand and agree with the customer's order.
- Remove the **5270 Series** from its packing material, checking to make certain that all parts are accounted for and no parts are damaged. Advise the shipper immediately if damage has occurred. Order any parts necessary to replace those which have been damaged. Keep the shipping container and packing material for future use. Check the packing list.
- Collect all necessary installation manuals for the instrument and accessories.

### ***3.1.4. Safety***

As is the case with any material handling equipment, certain safety precautions should be observed during operation.

- Never load the **5270 Series** beyond its rated capacity. Refer to the rating on the serial number plate if in doubt.
- Ensure that the structure which supports the Unirail is capable of withstanding the weight of the **5270 Series** plus its rated capacity load.
- Do not load the **5270 Series** if there is any evidence of damage to it or its supporting structure.

- Perform an inspection making certain that all hardware and electrical connections are secure.

### **3.1.5. Standard Installation**

The weigh rail, its approaches, the load cell, and their housing are arranged in a configuration that requires no space above the customer's normal supporting structure.

All components of the 5270 Series are assembled as one complete calibrated unit ready for installation into the existing monorail line.

- Install the 5270 Series monorail at the approach rails by direct attachment to the rail hangers.
- The scale should be installed level in both directions in the horizontal plane. If level condition along the rail cannot be obtained, out of level must not exceed 0.6 degrees, for 0.5 feet on the length of the weigh rail.
- There is no welding required. If any welding is required on any adjacent structure, perform the welding prior to scale installation. If welding is required after installation, the entire scale assembly, live and adjacent dead rails, should be physically removed prior to welding to avoid possible damage to the load cells.
- Use cast or fabricated steel hangers to support the scale structure. **DO NOT** use light gauge (cold-formed) steel hangers.

---

**NOTE:** *When installing the dead rail, ensure rails are in alignment. Apply anti-seize to bolts and torque to 16 ft lbs.*

---

---

**WARNING:** *DO NOT weld on the scale structure or damage to the load cells may occur.*

---

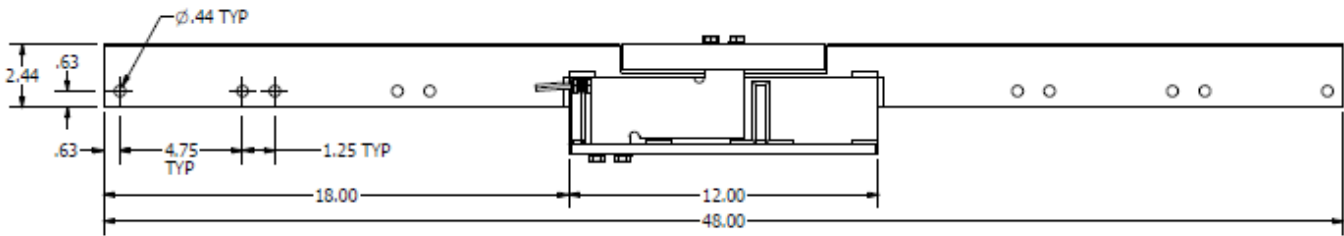
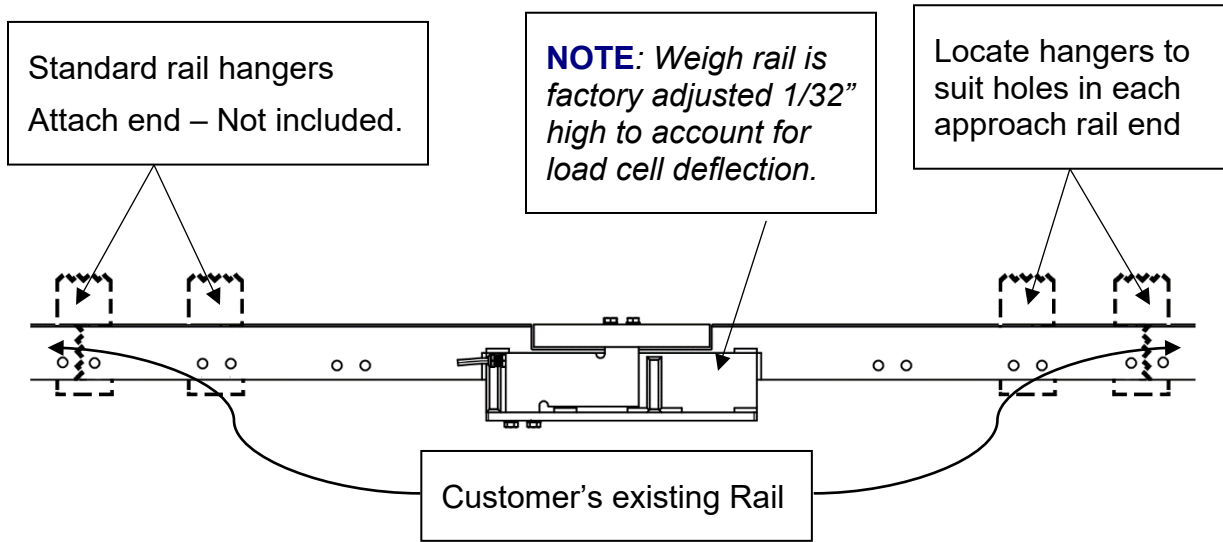

Front views

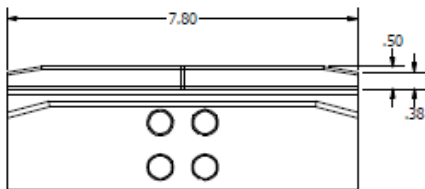

DETAIL A  
LIVE RAIL

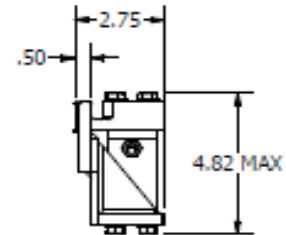

Side view

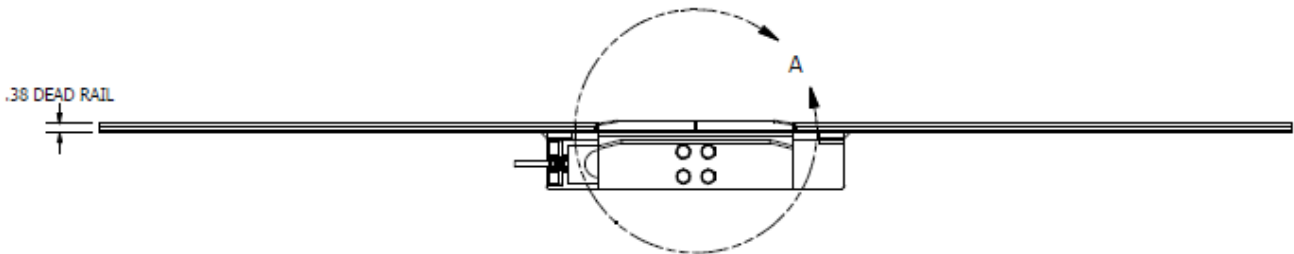

Top view

**NOTE: All dimensions are in inches**

### **3.1.6. Wiring**

After the 5270 Series is physically installed, install the weight instrument per the appropriate service manual, as follows:

1. Attach the 5270 Series cable to the instrument:

<b>Cable Leads</b>	
Green	+ Excitation
Blue	+ Sense
Black	– Excitation
Brown	– Sense
White	+ Signal
Red	– Signal
Shield	

2. Attach a length of 18-gauge wire from the scale structure to a suitable ground.

## **3.2. Operation**

### **3.2.1. Scale Operation Instructions**

1. Weigh empty roller and enter tare on instrument.
2. Set in NET position.
3. Roll onto the live section of the rail with the trolley position in the recessed section of the scale.
4. The weight is now taken in the static mode.
5. Repeat steps 2-4 for further weighments; step 1 if different roller is used

---

## Section 4: Service & Maintenance

---

### 4.1. Introduction

The weigh rail should remain in the center of its fixed approaches, and it must deflect freely. The weigh rail must remain free and unobstructed for proper performance. Periodic examination and debris cleaning from its gaps should be performed regularly. Do not lubricate, grease, or oil any part of the 5270 Series.

### 4.2. Replacement & Alignment Procedures

#### 4.2.1. Replacing the Loadcell

1. The 5270 Series load cell cable should be disconnected from the instrument.
2. Remove the top 4 screw (M8 hex head cap) from the top of the load cell. Gently remove the live rail and set aside.
3. Remove the 4 screws from the bottom of the load cell base plate.
4. Mount the replacement load cell, bottom first, to the base plate using the existing M8 hex head cap screws. Tighten finger tight.
5. Ensure the load cell is parallel to the rail, then torque the screws to approximately 75 ft lbs.
6. Mount the live rail to the load cell using the screws, finger tight only.
7. Ensure the live rail is in line with the dead rail, torque the load cell to approximately 75 ft lbs.
8. Reconnect the load cell cable to the instrument and recalibrate per the instrument's Service manual.

---

**NOTE:** Since the entire scale becomes an integral part of the overall monorail system, normal deflection of the system will **NOT** affect scale accuracy – in other words, the scale moves with adjacent rail, not in opposition to it, as there is no differential movement. However, the design of a safe, stable, supporting structure adjacent to the scale is essential and is the responsibility of the customer.

---

## Section 5: Parts

ITEM	PART NO.	QTY	DESCRIPTION
1	35260	1	RAIL WELDMENT, DEAD, 3/8" X 48"
2	11093	1	WASHER, LOCK, SS, 5/16"
3	35269	1	SCREW, CAP, HEX HEAD, M8-125 X 20 MM
4	35268	1	LOAD CELL, SS, SINGLE - POINT, 500 KG
5	36867	1	RAIL, LIVE
6	15656	1	NAME PLATE

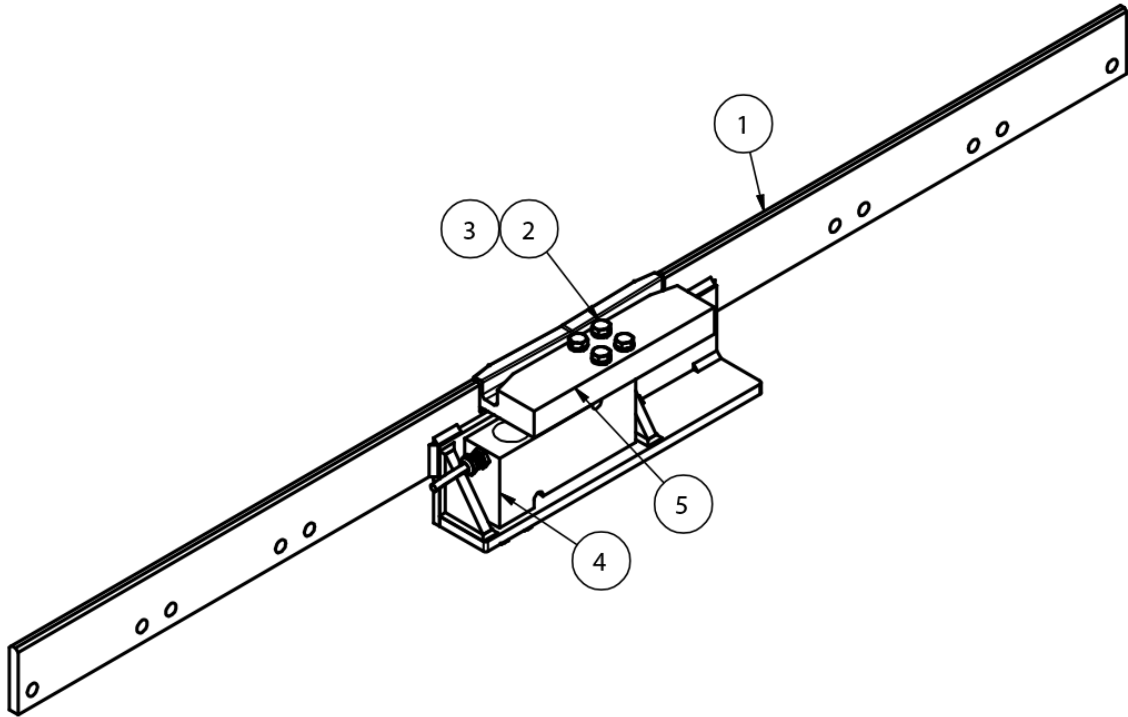



Manufactured by Fairbanks Scales, Inc.  
821 Locust Street  
Kansas City, MO 64106

[www.fairbanks.com](http://www.fairbanks.com)

---

**Monorail Scale**  
**Installation Manual**  
**Document 51439**