

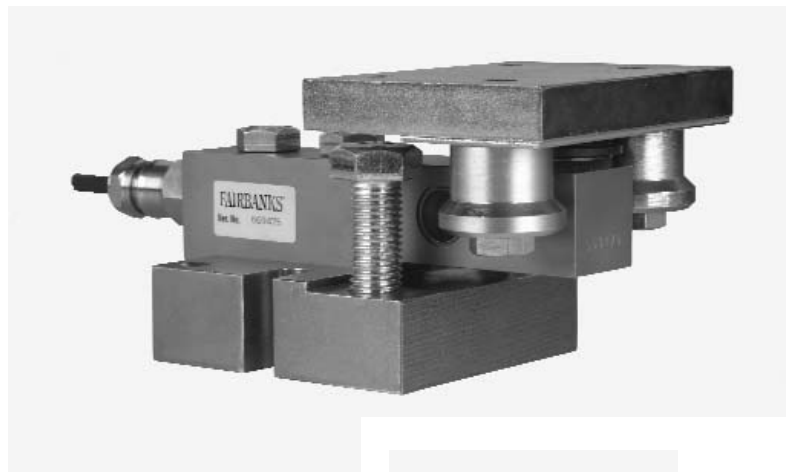

Omnicell

Models: 9111



Amendment Record

**Omnicell
9111**

50767

Manufactured by Fairbanks Scales Inc.
821 Locust
Kansas City, Missouri 64106

Issue #1	New Product
Revision 2	Inserted Load Cell Wiring Chart

Disclaimer

Every effort has been made to provide complete and accurate information in this manual. However, although this manual may include a specifically identified warranty notice for the product, Fairbanks Scales makes no representations or warranties with respect to the contents of this manual, and reserves the right to make changes to this manual without notice when and as improvements are made.

Table of Contents

Section 1: General Information	
A. Introduction	4
B. Specifications	4
C. Accessories	4
Section 2: Installation	
A. General Service Policy	5
B. Overview	5
C. Unpacking	5
D. Installation Instruction	6
Section 3: Parts List	
A. Parts List	10
B. Accessories	10
Appendix 1: Models	12

Section 1: General Information

A. Introduction

Fairbanks' Omnicell 9111 Series' tank weighing assembly is a compact, low profile weighing assembly designed for superior performance in light to medium weight ranges commercial and non-commercial.

OMNICELL® 9111 SERIES TANK WEIGHING ASSEMBLY FEATURES

- Capacities available from 500 lbs to 10,000 lbs.
- Slider plate compensates for thermal expansion.
- Mount assembly has built-in, two-directional bumpers.
- Low profile design for easy installation.
- Load cells sealed to industry's highest standard for environmental protection.
- Load cell constructed of 17-4 stainless steel for high caustic protection.
- Mounts available in 304 stainless and zinc plated steel.
- Factory Mutual approved for hazardous applications.
- Patented MV/V/Ohm calibration for ease of installation.
- NTEP approval pending.

B. Specifications

Mount Construction	304 stainless steel; zinc plated mild steel
Capacities (in lbs)	500, 1K, 2.5K, 5K and 10K
Full Scale Output (FSO)	2.0mV/v ± 0.05%
Combined Error (FSO)	≤ 0.03%
Non-Linearity (FSO)	0.02%
Hysteresis (FSO).	0.02%
Creep Error (30 min.)	≤ 0.05%
Compensated Temperature	14° F to 104° F (-10° C to 40° C)
Operating Temperature	-40° F to 176° F (-40° C to 80° C)
Excitation Voltage	5-15 VDC
Overload	Safe = 150%; ultimate = 300%
Sideload	Safe = 100%
Bridge Resistance	1000 ohms nominal
Load Cell Construction	Stainless Steel 17-4 PH
Sealing	Hermetic seal; cable entry sealed by glass to metal header
Load Cell Cable.	20 ft., polyurethane
Protection	IP 68
Approvals	Factory Mutual; NTEP pending

C. Accessories

- Mild Steel Uplift Protection with bolts.25460 (500-5k); 25462 (10k)
- Stainless Steel Uplift Protection with bolts. . .25461 (500-5k); 25463 (10k)

Section 2: Installation

A. General Service Policy

Prior to installation, it must be verified that the equipment will satisfy the customer's requirements as supplied, and as described in this manual. If the equipment cannot satisfy the application and the application cannot be modified to meet the design parameters of the equipment, the installation should not be attempted.

It is the customer / operator's responsibility to ensure the equipment provided by Fairbanks is operated within the parameters of the equipment's specifications and protected from accidental or malicious damage. Other than the procedures authorized in the Operating manual, no service, repair, or adjustments may be performed by unauthorized / untrained service personnel. Any unauthorized repairs will void any verbal, implied, or written warranties.

B. Overview

1. These instructions apply to the specific installation procedures. The procedures for instruments, printers and other peripherals are given in manuals specifically provided for those units.
2. All electronic and mechanical calibrations and or adjustments required to make this equipment perform to accuracy and operational specifications are considered to be part of the installation, and are included in the installation charge. Only those charges which are incurred as a result of the equipment's inability to be adjusted or calibrated to performance specifications may be charged to warranty.
3. Absolutely no physical or electrical modifications are to be made to this equipment. Electrical connections other than those specified may not be performed, and physical alterations are not allowed.
4. Before the installation is considered complete, the equipment is to be installed to meet or exceed any applicable weights and measures requirements, if applicable. The installing technician is responsible to make certain customer personnel are fully trained and familiar with the capabilities and limitations of the equipment. Be prepared to recommend the arrangement of components which will provide the most efficient layout, utilizing the equipment to the best possible advantage. The warranty policy must be explained and reviewed with the customer.

C. Unpacking

1. Check that all components are on hand, and agree with the customer's order.
2. Remove all components from their packing material, checking to make certain that all parts are accounted for and no parts are damaged. Advise the shipper immediately, if damage has occurred. Order any parts necessary to replace those which have been damaged. Keep the shipping container and packing material for future use. Check the packing list.

D. *Installation Instruction*

1. Items not Supplied
 - a. 3/8-16 UNC bolts- 4 required for each 500 lb, 1k lb, 2.5k and 5k lb assembly.
1/2-13 UNC bolts- 4 required for each 10k lb assembly.
 - b. 1/2-13 UNC Anchors/ bolts - 2 required for each 500 lb, 1k lb, 2.5k and 5k lb assembly.
5/8-11 UNC Anchors/ bolts - 2 required for each 10k lb assembly.
2. Raise the vessel to be supported by the Omnicell® assemblies and secure by safely blocking the vessel to the required height. See Figure 50767-1.

WARNING:

The Omnicell® assemblies **MUST** be orientated as per Figure 50767-2 or severe damage could occur to the vessel or assemblies.

3. Place each Omnicell® assembly onto a level surface under each support leg.
4. Set the assemblies for the correct orientation as per Figure 50767-2.
5. Adjust the load lifting/ support bolt until it is against the top plate. Insert the four (4) top mounting plate bolts and loosely tighten the bolts to the support leg for each assembly.
6. Mark the location of the anchor bolt locations. Slide the assembly back and drill the anchor hole locations. Re-position the load cell assembly, level, and anchor all assemblies.
7. Lower the vessel onto the top plate of each Omnicell® assembly. Tighten the bolts securing the load plates to each support leg of the vessel. Remove all cribbing blocks. Lower the load lifting/ support bolts on each assembly until the bolt has approximately 1/4" clearance and the load cell is bearing the vessel's weight.
8. Route the cables to the junction box and indicator. Wire the Omnicell® assemblies according to the appropriate junction box and indicator service manual. Calibrate as required.

Load Cell Wiring

- + EXC = Green
- EXC = Black
- + SIG = White
- SIG = Red

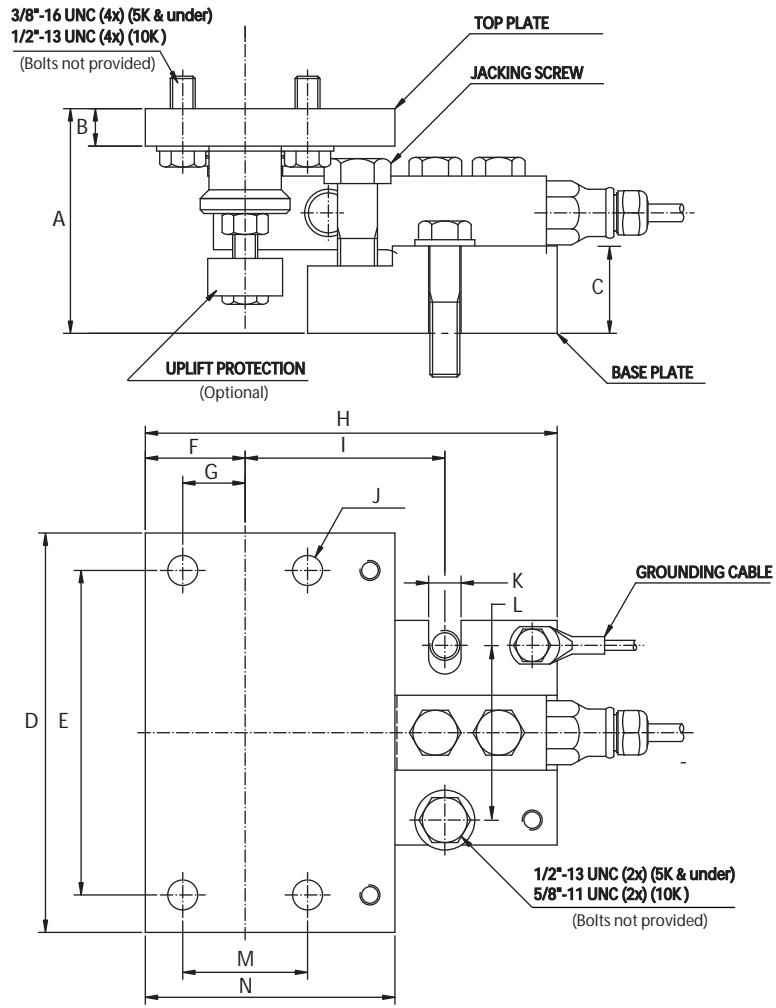

50767-1

DIMENSIONS (in inches) Corresponds to drawing above.

Capacity	A	B	C	D	E	F	G	H	I	J	K	L	M	N
5000 lb and under	3.54	0.59	1.38	6.30	5.12	1.57	0.98	6.50	3.15	0.47(4x)	0.51	2.75	1.97	3.94
10,000 lbs	5.12	0.98	1.97	7.87	6.69	1.97	1.38	8.27	4.13	0.57(4x)	0.63	3.94	2.76	4.72

Note:

- a. The load cell mounting bolts for the 500 - 2.5k assemblies must be torqued to 66 ft-lbs.
- b. The load cell mounting bolts for the 5k assemblies must be torqued to 88 ft-lbs.
- c. The load cell mounting bolts for the 10k assemblies must be torqued to 295 ft-lbs.

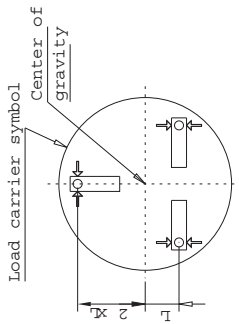

Figure 1

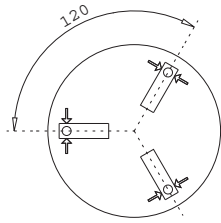

Figure 2

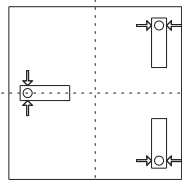

Figure 3

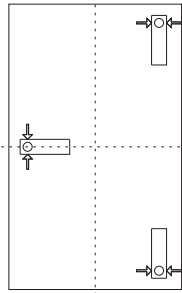

Figure 4

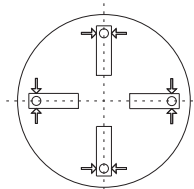

Figure 5

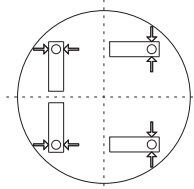

Figure 6

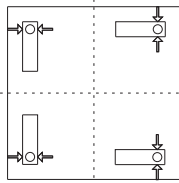

Figure 7

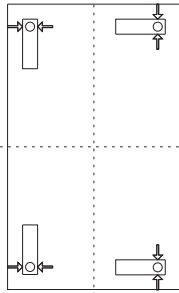

Figure 8

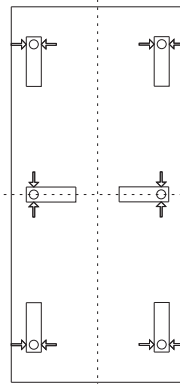
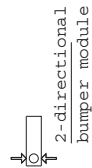

Figure 9

1. Each individual "2-directional bumper module" can be installed rotated 180 around it's loading point.
2. For scales with 3 modules, distances to center of gravity should be chosen with ratio 1:2, as shown in figure 1, which gives even load distribution.
3. For best stability, the loading points of the modules should be as far from one another as the scale structure allows.



This page was intentionally left blank.

Section 3: Parts List

A. Parts List

Item	Part Number	Description	Capacities
1	25524	Load cell, SS Hermetically Sealed	500 lb
	25525	Load cell, SS Hermetically Sealed	1,000 lb
	25526	Load cell, SS Hermetically Sealed	2,500 lb
	25527	Load cell, SS Hermetically Sealed	5,000 lb
	25528	Load cell, SS Hermetically Sealed	10,000 lb
2	3-6856-A	Grounding cable w/ bolts	ALL
3	4-6851-2	Sliding plate	500 - 5,000 lb
	4-6851-3	Sliding plate	10,000 lb
4	4-6843-1	Sliding loading pin	500 - 5,000 lb
	4-6845-1	Sliding loading pin	10,000 lb

B. Accessories

Item	Part Number	Description	Capacities
5	25460	Mild Steel Uplift w/ bolts	500 - 5000 lb
	25461	Stainless Steel Uplift w/ bolts	500 - 5000 lb
	25462	Mild Steel Uplift w/ bolts	10,000 lb
	25463	Stainless Steel Uplift w/ bolts	10,000 lb

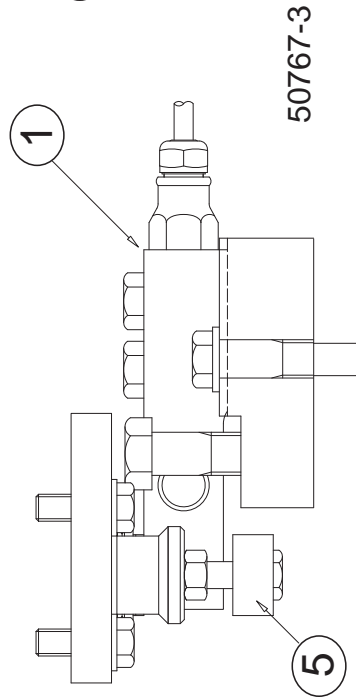
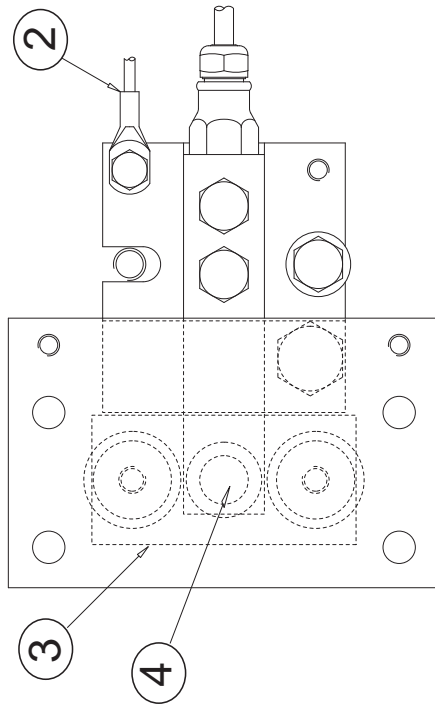

50767-3

Appendix I : Models

A. Mild Steel

Product Number	Description
25438	Omniceil, w/ Zinc plated mild steel, ss hermetic load cell, 500 lb capacity
25439	Omniceil, w/ Zinc plated mild steel, ss hermetic load cell, 1k lb capacity
25440	Omniceil, w/ Zinc plated mild steel, ss hermetic load cell, 2.5k lb capacity
25441	Omniceil, w/ Zinc plated mild steel, ss hermetic load cell, 5k lb capacity
25442	Omniceil, w/ Zinc plated mild steel, ss hermetic load cell, 10k lb capacity

B. Stainless Steel

Product Number	Description
25443	Omniceil, stainless steel mount, ss hermetic load cell, 500 lb capacity
25444	Omniceil, stainless steel mount, ss hermetic load cell, 1k lb capacity
25445	Omniceil, stainless steel mount, ss hermetic load cell, 2.5k lb capacity
25446	Omniceil, stainless steel mount, ss hermetic load cell, 5k lb capacity
25447	Omniceil, stainless steel mount, ss hermetic load cell, 10k lb capacity