



Portable Platform Scale

BPP1000 Series

BPP2000 Series





Disclaimer

Every effort has been made to provide complete and accurate information in this manual. However, although this manual may include a specifically identified warranty notice for the product, Fairbanks Scale Inc. makes no representations or warranties with respect to the contents of this manual, and reserves the right to make changes to this manual without notice when and as improvements are made.

Fairbanks Scale Inc. shall not be liable for any loss, damage, cost of repairs, incidental or consequential damages of any kind, whether or not based on express or implied warranty, contract, negligence, or strict liability arising in connection with the design, development, installation, or use of a scale.

© Copyright 1990-2015

This document contains proprietary information protected by copyright. All rights are reserved; no part of this manual may be reproduced, copied, translated or transmitted in any form or by any means without prior written permission of the manufacturer.

Amendment Record

Portable Platform Scale

BPP1000 Series
BPP2000 Series

Document 50699

Manufactured by Fairbanks Scales Inc.
821 Locust St.
Kansas City, MO 64106

Created	08/1990	
Revision 1	8/1990	Released Manual
Revision 2	11/2006	Updates made to include BPP2000; Revisions in text formatting, illustration updates, Descriptions, and processes
Revision 3	04/2012	Corrected parts list description
Revision 4	03/2013	Misc. revisions
Revision 5	08/2015	Updated format and graphics

Table of Contents

SECTION 1: INTRODUCTION 9

Scope of This Manual 9

Modifications 9

Customer/Operator Responsibilities 9

Repair Restrictions 9

Service Responsibility 9

Operating Requirements 9

Description 10

Specifications 10

SECTION 2: INSTALLATION 11

Unpacking 11

Tools Required for Assembly 11

Base Assembly 12

Pillar and Beam Assembly 14

Zeroing the Beam 16

Troubleshooting 17

SECTION 3: PARTS 18

Parts List 18

Parts Diagram 20

Section 1: General Information

Scope of This Manual

This manual provides instructions for the **Portable Platform Scale Models BPP1000** and **BPP2000**.

- Please read this manual carefully before assembling.
- Untrained personnel should not attempt to make any adjustments not specified in these instructions.

Modifications

Absolutely **NO PHYSICAL ALTERATIONS** (mounting holes, etc.) are to be made to this equipment.

Customer/Operator Responsibilities

It is the customer/operator's responsibility to maintain and protect the scale from accidental or malicious damage.

Repair Restrictions

The **Portable Platform Scale** must be repaired following specific current warranty policies for this product.

Service Responsibility

The **Portable Platform Scale** is factory calibrated, and supplied to the customer ready to be unpacked, assembled and placed into operation.

Operating Requirements

- The scale must be operated on a firm, level surface.
- A bubble level is provided for checking the level condition of the scale.

Description

The **Portable Platform Scale** is a compact portable unit designed for light to medium operation. It requires no external power connections and will operate in a wide variety of environmental conditions.

Specifications

DIMENSIONS

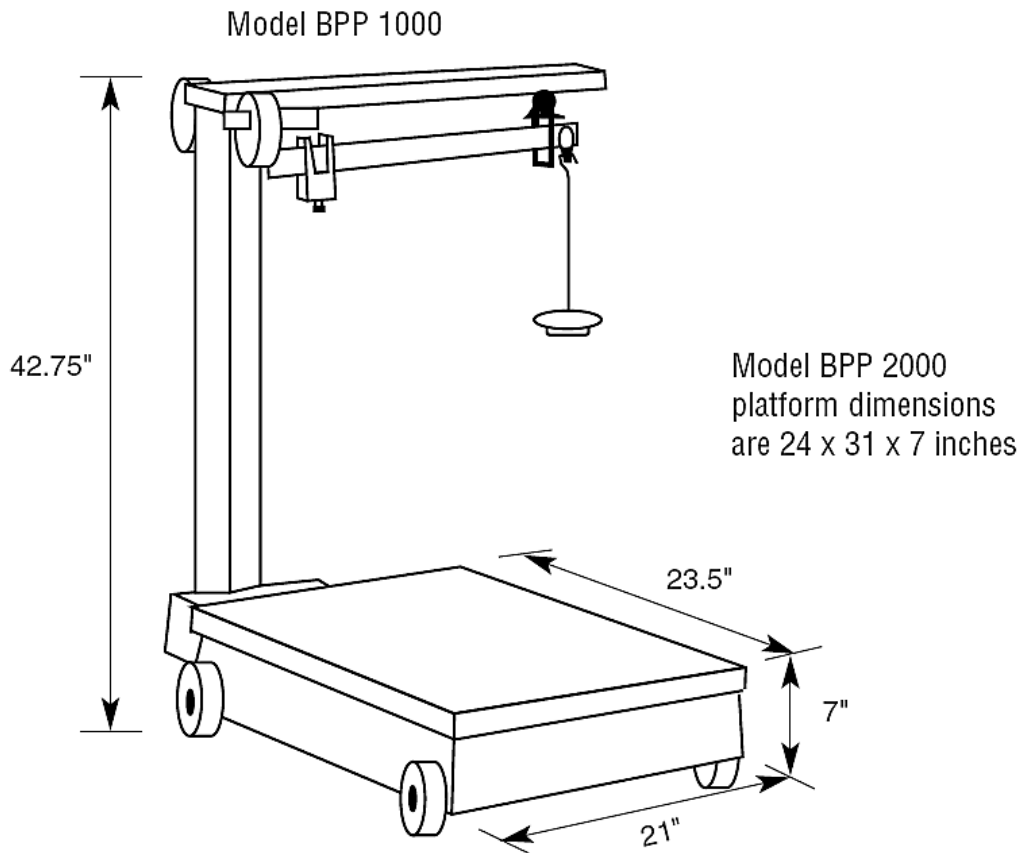

Specifications	BPP 1000	BP 2000
Capacity	1000 lbs.	2000 lbs.
Division Size	1/2 lb.	1 lb.
Platform	Cast iron base	Cast iron base
Platform Size	21" x 23½"	24" x 31"
Overall Height	42¾"	42¾"
Platform Height	About 7"	About 7"
Weighing System	Cast Iron Lever System	Cast Iron Lever System



Section 2: Installation

Unpacking

- Check the packing materials for loose parts or hardware before disposal.
- Check that all parts are included using the packing list.
- Check for component damage that may have occurred during shipping
- The scale platform under-structure arrives fully assembled, with the levers in their proper positions.

Tools Required for Assembly

- Needle nose pliers
- Flat head and Phillips head screwdrivers
- An adjustable wrench

Base Assembly

NOTE: The following descriptions refer to “Key#” (#4, etc.) to describe parts. Use the parts list and Key# in the list to identify all such parts.

1. Place the **Platform Sub Assembly** on the floor upside-down, preferably on 2x4 blocks to raise it up off the floor, if possible.

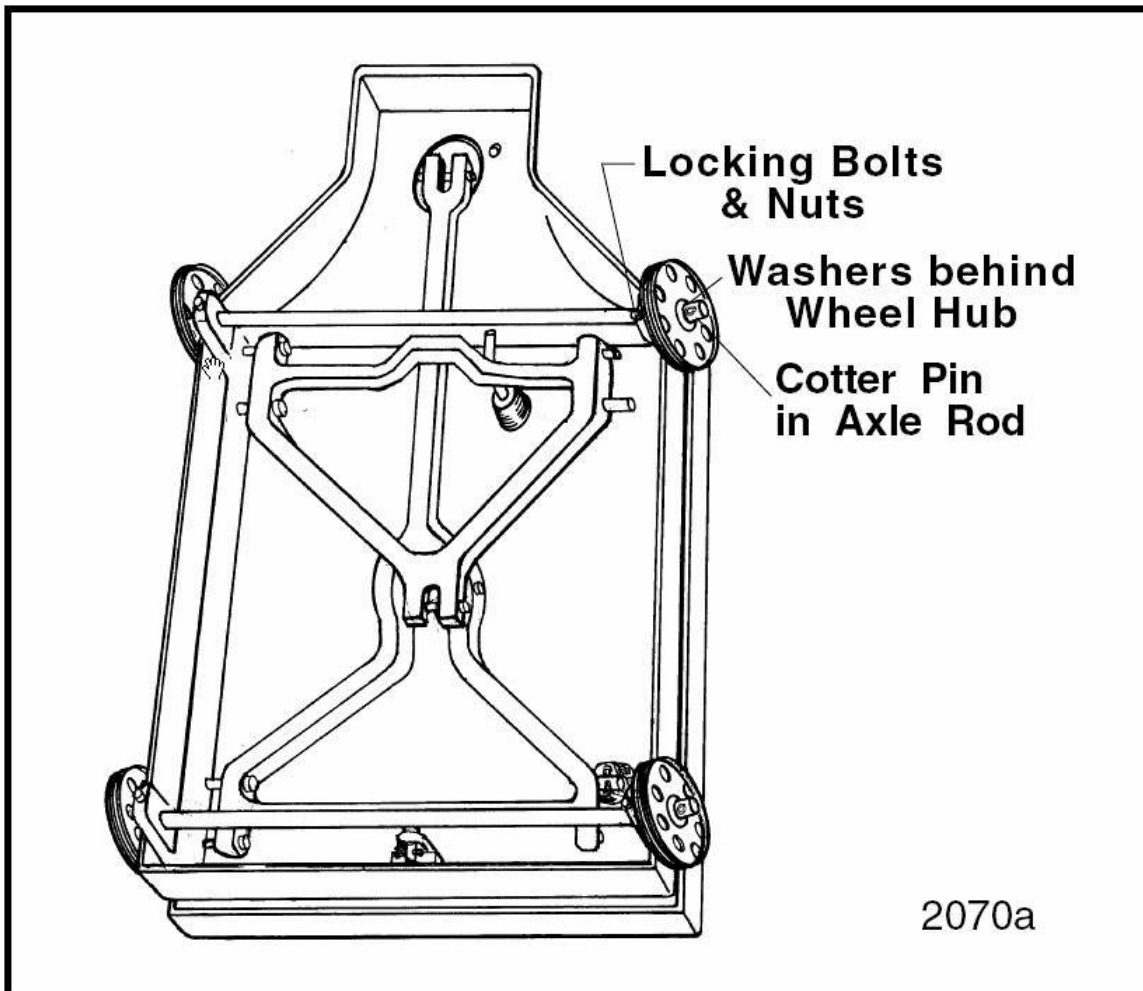

2. Remove the cotter pins and washers from one side of the Axle Rod (#19).
 - Axle assembly includes an affixed cotter pin (#17), a 5” wheel (#16), and then a flat washer (#18).
3. Insert the Axle Rod Assembly through the two axle rod holes, side-to-side.
4. Place one flat washer (#18), then a wheel (#16) over the other end.

Base Assembly, Continued

5. Insert a cotter pin (#17) through the Axle Rod.
 - Using needle nose pliers, bend back both halves of the cotter pin to secure the wheel assembly.
6. Repeat steps two through four (2-4) for the second axle.
7. Center the axles in the base, and then insert the four locking screws (#15) into each of the tapped holes in the bottom of the base.
 - Located directly under the axle holes
8. Tighten the locking screws, and then secure the Lock Nuts (#14).
9. Turn the platform over so it sets on the wheels.



After inserting the four Cotter Pins, center the axles, tighten the Locking Screws, and then secure the Lock Nuts.

Pillar and Beam Assembly

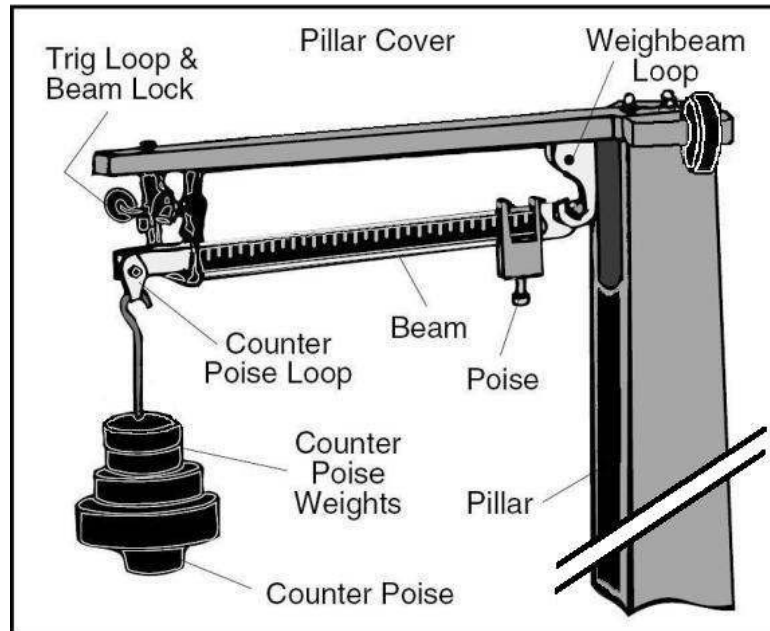

1. Thread the two (2) Pillar Support Rods (#1) into the tapped holes provided in the base.
 - The end with the longer thread should fit into the platform (about 1/2 inch).
2. Place the Pillar (#2) down over the support rods with the pillar cut-outs facing the right and left of the platform.
3. Insert the Steelyard Rod (#35) down through the pillar.
 - The bent hook on top; the loose Swivel Hook on the bottom.
 - The hook opening should be toward the platform when properly placed.
 - **DO NOT** remove the washers from the Steelyard Rod.
4. Hook the Steelyard Rod (#35) to the Long Lever Tip Pivot (#34).
 - Temporarily, hook the upper end of the Steelyard Rod on the pillar cut-out.

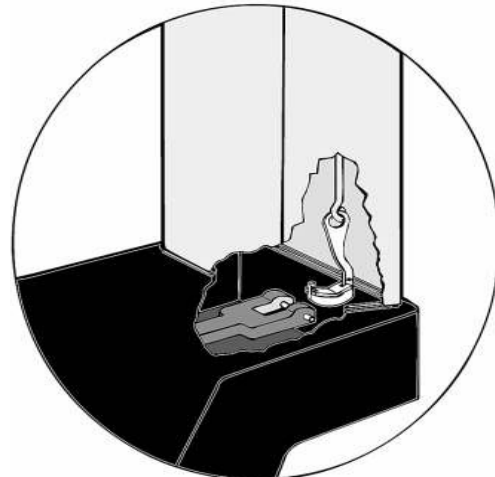

Hook the Steelyard Rod to the Long Lever Tip Pivot.

Pillar and Beam Assembly, Continued

5. Place the cast iron Beam Support (#39) over the Steelyard Rod with the hook facing to the right (when facing the scale platform).
6. Insert the Beam Cap (#45) onto the pillar rods.
 - The long side will be to the right.
7. Place Washers over the pillar rods, and then screw on the two (2) Acorn Nuts (#44).
 - Hand-tighten only, at this time.
8. On the butt end on Beam Assembly, hook the bottom Load Loop to the Steelyard Rod.
 - See image to the right.
9. Pulling the Beam up, hook the top Fulcrum Loop (of the Beam Assembly) to the hook on the Beam Support (#39).
 - The beam should hang loosely from the two hooks.
10. Insert the Beam Lock (#43) onto the front end of the Beam Assembly.
 - See image to the right.
11. Slide the Beam Lock (#43) over the Beam and align it with the two (2) holes in the Beam Cap (#45).
12. Fasten the Beam Lock to the Beam Cap with the two (2) Hex Bolts (#46).
 - The handle faces the scale platform.
13. Hang the Counterpoise Assembly (#54) from the Beam Tip Loop.
14. Set the Sliding Poise (#52) to **zero** and hand tighten the screw on its under-side.
 - Check that the beam is straight and does not touch the sides of the Beam Lock.
 - Shift the Cap if necessary to straighten, and then tighten the acorn nuts securely with an adjustable wrench.



Hook the bottom Load Loop to the Steelyard Rod. Pulling the Beam up, hook the top Fulcrum Loop.



Insert the Beam Lock onto the end of the Beam Assembly, then align the Beam Lock under the two holes in the Beam Cap. Fasten this assembly with the two Hex Bolts.

Zeroing the Beam

Note: Check that the weighing platform "floats" on the levers' pivots and bearings and does not bind or set to one side. The platform should return to a centered position if moved to any position then released.

1. Unlock the Beam Lock Loop to allow the beam to balance.
 - The beam should move up and down freely coming to rest in the center of the trig lock opening.
2. Balance the beam by adjusting the balance ball at the butt end of the beam, using a screwdriver.
 - Turning the screw CW (Clock-Wise) **raises** the beam
 - Turning the screw CCW (Counter Clock-Wise) **lowers** the beam.

The scale is now assembled.

Troubleshooting

If the beam will not balance using the balance ball, check the following:

- Is the poise is at 0 (zero), and is the poise screw is snug?
- Is the platform free and “floating”?
- Is the beam load rod connected properly on both ends?
- Is something under the platform inhibiting the levers (floor debris)?
- Are there any weights on the counterpoise hanger, and is it on the Tip Loop?
- Is the beam hanging from the middle loop?
- Is the Beam Lock Loop (#43) open?

Apply a slight pressure to the scale platform and see if the beam tip rises.

- If it does, continue onto balancing step.
- If it does not, recheck mechanical assembly.

If the scale beam still does not balance (beam rises with slight pressure), perform the following:

1. Use a screwdriver to 'center' the balance ball at the butt end of the beam.
2. If the beam is up, apply small amounts of weight (BBs) to the top of the Counterpoise.
3. If the beam is low, remove the Counterpoise hanger (#54), loosen the hanger rod by turning and holding the bottom nut, and remove a small amount of lead shot.
4. Add or remove small amounts of weight until beam balances.
5. Secure the counterpoise hanger with added or removed weight.

Section 3: Parts

Parts List

Key #	BPP1000 Part #	BPP2000 Part #	Description
	55017		BPP1000 Series, 24" x 21", 1K x .5, Portable Beam
		55789*	BPP2000 Series, 24" x 31", 2K x 1, Portable Beam
1	71622	78796*	Set of Pillar Rods
2	58933	77228*	Pillar
3	95847		Cover Assembly, Platform
4	95848		Frame
5	95855		Cotter Pin
6	58937		Bearing, Platform
7	95856		Screw, Phillips Head
8	95857		Screw, Allen
9	95858		Level, Bubble
10	95859		Pin, Corner Loop
11	71623		Loop, Corner
12	71624		Bearing, Corner Loop
13	71625		Cotter Pin
11, 12, 13	58938		Corner Loop Assembly
14	95867		Nut, Hex
15	95868		Bolt, Hex Head
16	95869		Wheel, 5" Diameter
17	71628		Cotter Pin
18	71629		Washer, Flat
19	71630		Axle
24	95861		Pivot
25	72948		Lever Assembly, Short
26	58939		Center Connection Assembly (26, 27, 28, 29, 32)
27			Clip, Center Connection
28			Link, Center Connection
29			Cotter Pin
30	95862		Pivot
31	95863		Pivot
32		75712*	Upper Bearing, Center Connection
33	72947	75713*	Long Lever Assembly
34	95864		Long Lever Tip Pivot
35	58934		Steelyard Rod Assembly

XXXXX* Indicates a part number for the BPP2000.

Parts List, Continued

Key #	BPP1000 Part #	BPP2000 Part #	Description
36, 37, 38	71594		Loop Assembly
37			Cotter Pin
38			Bearing
39	95839	77229*	Support Beam
40	71591		Loop
40, 41, 42	71595		Loop Assembly
41			Cotter Pin
42			Bearing
43	95840		Lock Assembly, Beam
44	71592		Acorn Nut (2)
45	95841	77227*	Cap, Beam
46	71593		Hex Bolt (2)
47			Screw, Balance Weight Adjustment
48			Weight, Balance
47, 48, 49	95843		Beam Assembly (100 x 0.5 lb)
	55017		BPP1000 1K x 0.5 NON-NTEP Beam
		71633*	BPP2000 2000 lb. Portable Beam
		75711*	BPP2000 BPP2000 Beam Insert
50	71632		Pivot
51			Pivot
51, 52, 53	95842		Poise Assembly
53			Loop
54, 58, 59, 60	58935		Counterpoise Stem Assembly
55, 56, 57		71598*	Set of SE Weights
55, 56, 57		74392*	Set of Metric Weights
55	58936		1 lb. Counterpoise Weights
56	95853		2 lb. Counterpoise Weights
57	95854		4 lb. Counterpoise Weights
58			Top, Counterpoise
59			Cup, Counterpoise
60			Nut, Hex
61	95865		Pin
62	95866		Cotter Pin
N/S	71586		Set of Corner Loops
N/S	71587		Set of Bearing Corner Loops

XXXXX* Indicates a part number for the BPP2000.

Parts Diagram

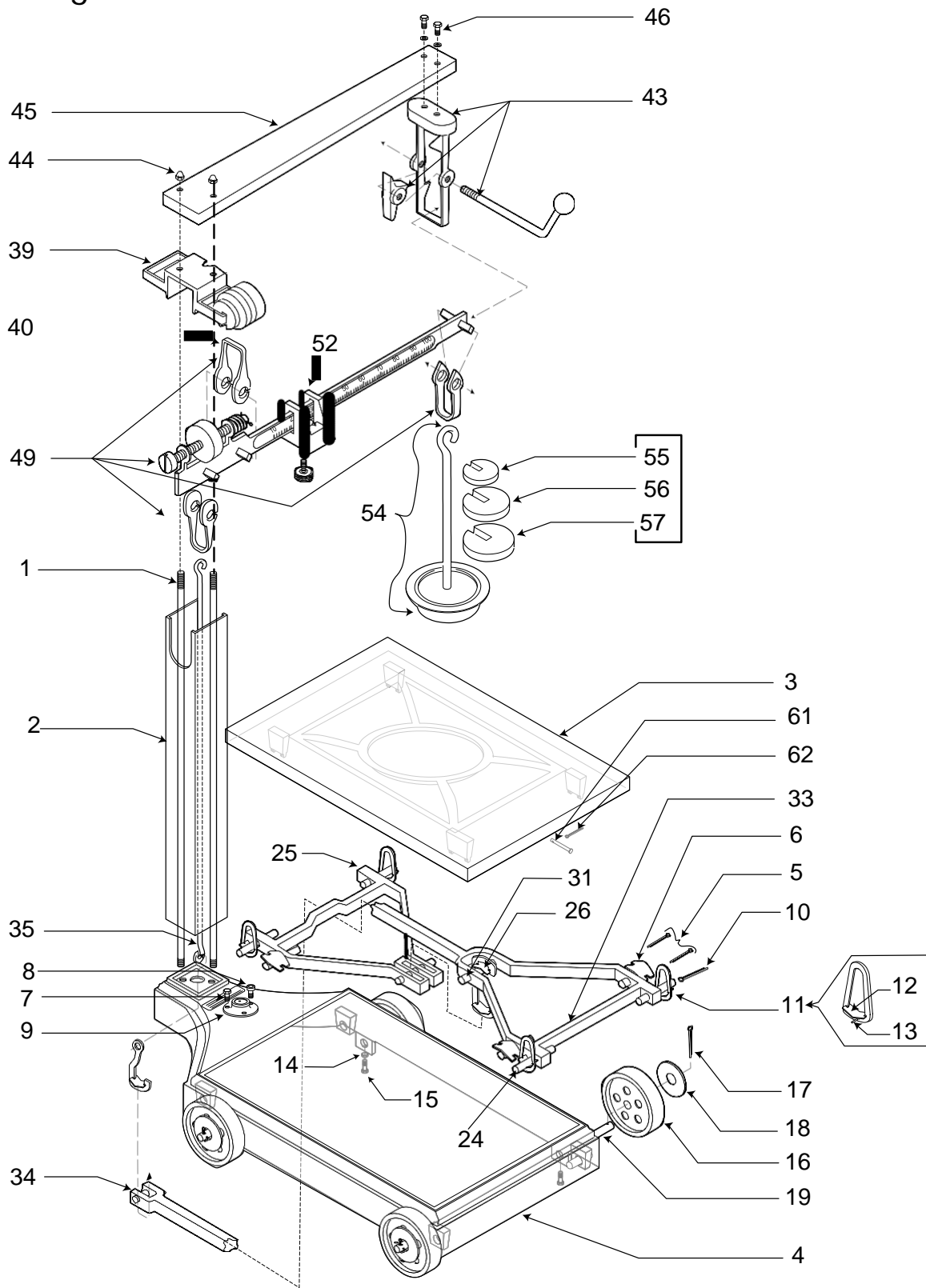



Portable Platform Scale
Models BPP1000 & BPP2000

Manufactured by Fairbanks Scales, Inc.

821 Locust Street
Kansas City, MO 64106

www.fairbanks.com

Document 50699