

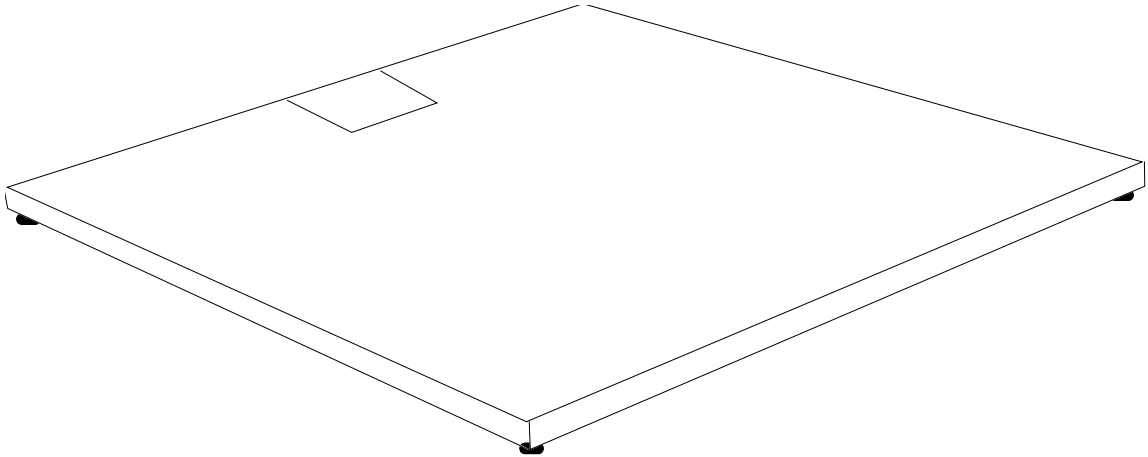

Aegis Industrial Mild Steel Floor Scale



Amendment Record

AEGIS INDUSTRIAL MILD STEEL FLOOR SCALE

Document 51102

Manufactured by Fairbanks Scales Inc.

821 Locust

Kansas City, Missouri 64106

Created	2/08	Created Document
Revision 1	2/08	Document Release
Revision 2	03/08	Revised date of load cell(s) Removed references to stainless steel model Altered image: 21896 MS
Revision 3	11/08	Updated Parts List Table Labels and Descriptions
Revision 4	02/09	Updated Load Cell Parts Information
Revision 5	04/09	Added Load Cell Impedance and mV/V
Revision 6	04/10	Updated manual per ECO 641 for the parts list added 11175.
Revision 7	08/12	Updated manual with adjusting feet drawing and instruction. Added updated pit drawing.
Revision 8	05/13	Updated manual with available scale modifications.
Revision 9	02/16	Updated Installing Accessories > Installing Bolt Down Plates
Revision 10	11/18	Updated Parts List

Disclaimer

Every effort has been made to provide complete and accurate information in this manual. However, although this manual may include a specifically identified warranty notice for the product, Fairbanks Scales makes no representations or warranties with respect to the contents of this manual, and reserves the right to make changes to this manual without notice when and as improvements are made.

Fairbanks Scales shall not be liable for any loss, damage, cost of repairs, incidental or consequential damages of any kind, whether or not based on express or implied warranty, contract, negligence, or strict liability arising in connection with the design, development, installation, or use of the scale.

© Copyright 2008-2018

This document contains proprietary information protected by copyright. All rights are reserved; no part of this manual may be reproduced, copied, translated or transmitted in any form or by any means without prior written permission of the manufacturer.

Table of Contents

SECTION 1: GENERAL INFORMATION	6
1.1. Introduction.....	6
1.2. General Service Policy	6
1.3. Users' Responsibility	8
SECTION 2: SCALE INSTALLATION.....	9
2.1. Pre-Installation.....	9
2.1.1. <i>Checklist</i>	9
2.1.2. <i>Unpacking</i>	9
2.1.3. <i>Equipment Checkout</i>	10
2.1.4. <i>Loading and Unloading</i>	11
2.2. Scale Installation	12
2.3. Calibration Steps	13
SECTION 3: INSTALLING ACCESSORIES	15
3.1. Installing Bolt-Down Plates	15
3.2. Installing Ramps	16
3.3. Installing Bumper Guards	16
3.4. Installing Pit Frames	17
SECTION 4: PARTS REPLACEMENT.....	19
4.1. Load Cell Replacement	19
4.1.1. <i>Load Cell Specifications</i>	20
4.2. Junction Box Replacement Steps	20
4.3. Foot Assembly Replacement Steps	21
SECTION 5: PARTS.....	22
5.1. Parts List	22
5.2. Parts Diagram	23
APPENDIX I: LOAD CELLS.....	24
APPENDIX II: MODEL MATRIX.....	26
APPENDIX III: ACCESSORIES	27
A. Ramps, Bumper Guards and Pit Frames	27
B. Bolt-down Plates, Eyebolts and Hole Plugs	27
APPENDIX IV: PIT FRAME INSTALLATION.....	28
APPENDIX V: SCALE MODIFICATIONS	29
A. Available Modifications List.....	29
B. Modification Descriptions.....	29



APPENDIX VI: ACC 3000-1A QMB 32

- A. Component Description 32
- B. Installation 32
- C. Wiring 33
- D. Grounding..... 33
- E. Parts List 34

APPENDIX VII: ACC 2801 35

- A. Introduction..... 35
- B. Wiring Load Cells 35
- C. Wiring ISC to ISIB:..... 37
- D. ISC Switch Settings: 37
- E. Grounding..... 37
- F. Parts List 38

APPENDIX VIII: ACC 2802 39

- A. Introduction..... 39
- B. Interface Connection Layout..... 39
- C. Wiring Load Cells 40
- D. ISC Switch Settings: 41
- E. Grounding..... 41
- F. Parts List 42

Section 1: General Information

1.1. INTRODUCTION

The **Aegis Floor Scale** uses a standard junction box for interfacing to all analog weight indicators.

- The scale platform is shipped in a crate, fully assembled and wired.
- The floor scale sizes range from **30" x 30" to 6' x 8'**.
- The floor scale capacities range from **1K to 10K (lbs)**.
- Both scale types are equipped with a **twenty-five (25) foot** interface cable.
- The junction box is constructed of stainless steel and all models have threaded holes in the decks for attaching eyebolts to facilitate installation and cleaning.

1.2. GENERAL SERVICE POLICY

Prior to installation, **always** verify that the equipment satisfies the customer's requirements as supplied, and as described in this manual.

If the equipment cannot satisfy the application and the application cannot be modified to meet the design parameters of the equipment, **the installation should NOT be attempted.**



It is the **customer/operator's responsibility** to ensure the equipment provided by Fairbanks is operated within the parameters of the equipment's specifications and protected from accidental or malicious damage.

W A R N I N G

Absolutely NO physical, electrical or program modifications, other than selection of standard options and accessories, can be made by customers to this equipment.

Repairs are performed by Fairbanks Scales Service Technicians and Authorized Distributor Personnel ONLY!

Failure to comply with this policy voids all implied and/or written warranties.

1.2. GENERAL SERVICE POLICY, CONTINUED

- Check all devices for proper operation. If any error messages occur, refer to Troubleshooting or the proper manual of that device.
- ***Only those charges which are incurred as a result of the equipment's inability to be adjusted to performance specifications may be charged to warranty.***
- No physical alterations (mounting holes, etc.) are allowed during installation.

The installing technician is responsible that all personnel are fully trained and familiar with the equipment's capabilities and limitations before the installation is considered complete.

- All electrical assemblies must be replaced as assemblies or units.
 - Replacement of individual components is not allowed.
 - These components must be returned intact for replacement credit per normal procedures.
- All electronic and mechanical adjustments are considered to be part of the installation and are included in the installation charge(s).
 - Included is any required computer programming or upgrades.
 - Included are any accuracy and/or operational specification changes.
- The AC receptacle / outlet shall be located near the Indicator and easily accessible.
- Electrical connections other than those specified may not be performed.
- The technician must be prepared to recommend the arrangement of components which provide the most efficient layout, utilizing the equipment to the best possible advantage.
- The warranty policy must be explained and reviewed with the customer.

1.3. USERS' RESPONSIBILITY

- All electronic and mechanical calibrations and/or adjustments required for making this equipment perform to accuracy and operational specifications are considered to be part of the installation.
 - They are included in the installation charge.
 - Only those charges which are incurred as a result of the equipment's inability to be adjusted or calibrated to performance specifications may be charged to warranty.

It is the owner's responsibility to document, notify, and follow-up regarding shipping damage with the carrier.

- Absolutely no physical, electrical or program modifications other than selection of standard options and accessories are to be made to this equipment.
- The equipment consists of printed circuit assemblies which must be handled using ESD handling procedures, and must be replaced as units.
 - Replacement of individual components is not allowed.
 - The assemblies must be properly packaged in ESD protective material and returned intact for replacement credit per normal procedures.



Section 2: Scale Installation

2.1. PRE-INSTALLATION

2.1.1. Checklist

The following points should be checked and discussed with the **Area Sales Manager and/or customer**, if necessary, before the technician goes to the site and installs the equipment.

- ✓ Check the customer's application to make certain it is within the capabilities and design parameters of the equipment.
- ✓ If the installation process might disrupt normal business operations, tell the customer and ask that they make ample arrangements.
- ✓ Be sure that the equipment operator(s) are available for training.
- ✓ The service technician reviews the recommended setup with the Area Sales Manager or Area Service Manager, and together they identify all necessary variations to satisfy the customer's particular application.



2.1.2. Unpacking

Follow these guidelines when unpacking all equipment.

- ✓ Check in all components and accessories according to the customer's order.
- ✓ Remove all components from their packing material, checking against the invoice that they are accounted for and not damaged.
 - Advise the shipper immediately, if damage has occurred.
 - Order any parts necessary to replace those which have been damaged.
 - Keep the shipping container and packing material for future use.
 - Check the packing list.
- ✓ Collect all necessary installation manuals for the equipment and accessories.
- ✓ Open the equipment and perform an inspection, making certain that all hardware, electrical connections and printed circuit assemblies are secure.
- ✓ Do not reinstall the cover if the final installation is to be performed after the pre-installation checkout.



2.1.3. Equipment Checkout

Position the equipment with these points in mind:

- ✓ Intense direct sunlight can harm the display.
- ✓ Do not locate near magnetic material or equipment/Indicators which use magnets in their design.
- ✓ Avoid areas which have extreme variations in room temperatures. Temperatures outside the Indicator's specifications will affect the weighing accuracy of this product.
- ✓ Do not load the platform if there is any evidence of damage to the platform or supporting structure.



2.1.4. Loading and Unloading

1. Select a location that is flat, solid, level, and one that fully supports the weight of the platform plus a full capacity load.
2. Remove the top of the crate and all packing material.
3. Screw the **two (2) eyebolts** into the threaded adapters in the platform top.
4. Use a forklift or other lifting means, along with chains, cables, or nylon straps to remove the scale from the crate bottom.

TWO TYPES of EYE BOLTS

✓ Closed Gap Eyebolts

- Open Gap Eyebolts (**NOT USED**)
- Lifting Hooks (**NOT USED**)

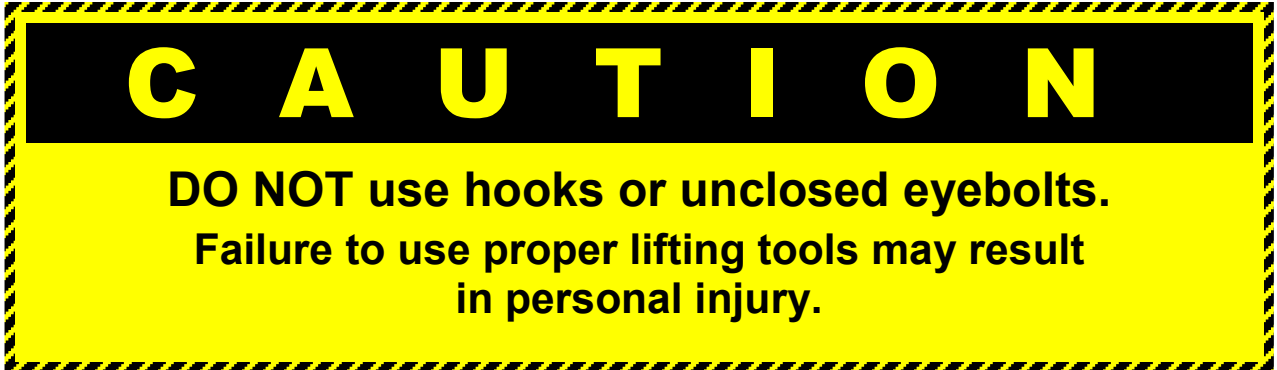
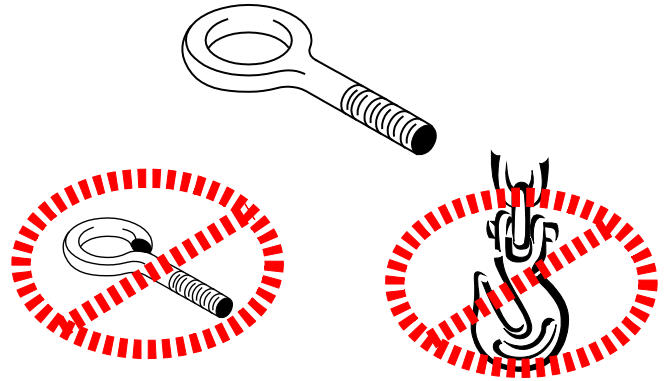

5. Set the scale so that the interface cable exits in a direction where it can be protected.
 - If possible, use a cable protector to reduce 'trip' hazards and to protect the interface cable from being damaged.
 - The scale is shipped with the threaded legs of the feet up tight against the load cells.
6. Remove the plugs at the corners of the scale.

2.2. SCALE INSTALLATION

1. Insert and turn the feet clockwise a minimum of four (4) complete turns with a large screwdriver.

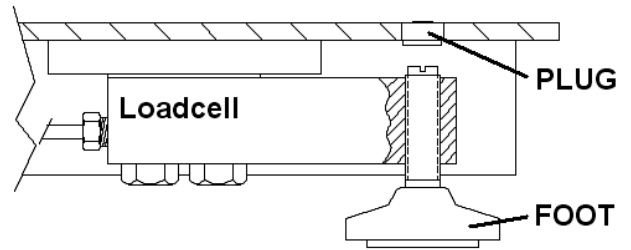

2. Wire the scale cable to the proper type indicator, as shown in the chart below.

WIRE COLOR	FUNCTION
Black	(-) Excitation
Red	(+) Excitation
Yellow	Shield
Green	(+) Signal
White	(-)Signal

3. Once the scale platform is completely wired to the indicator, calibrate the unit.
 - Follow the appropriate indicator service manual to ensure a good calibration.

2.3. CALIBRATION STEPS

Adjust the analog interface indicator to the platform.

- Install all the corners to within **one (1) division of each other at 25% of rated capacity.**
- Follow the appropriate indicator service manual to ensure a proper calibration.

1. Center the four **Junction Box Potentiometers** by turning the adjustment screw **counter-clock-wise position** until a clicking sound is heard, then turning each of them back **clock-wise ten (10) turns**.
 - Total number of turns is **twenty**.

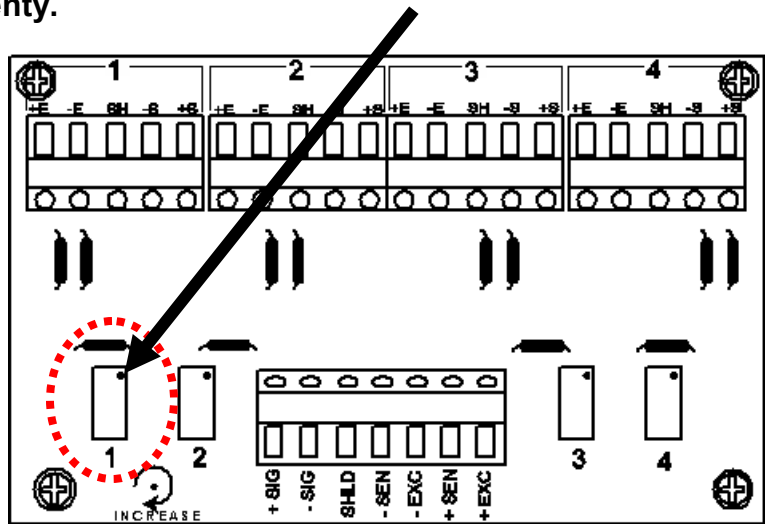

2. Identify the platform corner numbers.
3. Place a concentrated weight (**25%** of platform capacity) onto **corner #1**, then move it to **#2, #3** and **#4**, noting the displayed reading on each corner.
4. Identify the lowest reading, and then place the concentrated weight on this corner.

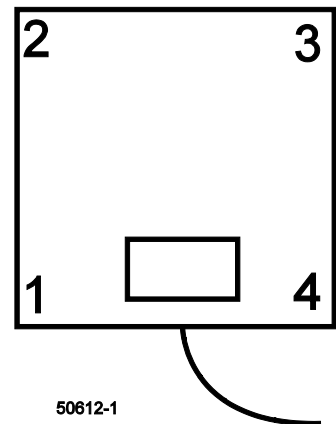

2.3. CALIBRATION STEPS, CONTINUED

CORNER ADJUSTMENTS

If corners require adjustment, follow these steps.

1. Place the concentrated weight on the corner displaying the lowest weight.
2. Turn the adjustment on the potentiometer clockwise (**CW**) to the displayed weight so it reads the same as the highest reading.
3. Repeat this procedure while rechecking all corners until they are equal.

IMPORTANT NOTE: *When moving the weight(s) from corner to corner, **DO NOT** zero the scale. The purpose is to adjust the corners to be the same, and not to perform a correct calibration.*

4. Perform a zero reference check with an unloaded platform.
5. Repeat the corner test to ensure all readings are the same before proceeding.

NO CORNER ADJUSTMENTS

*If corners **do not** require adjustment, follow these steps.*

1. Remove all weights.
2. Zero the indicator.
3. Perform a final calibration with test weights.
4. Follow the appropriate indicator service manual to ensure a proper calibration.

Section 3: Installing Accessories

3.1. INSTALLING BOLT-DOWN PLATES

Bolt down plates keep the scale from sliding or moving when loads are applied. The plates are bolted using anchors at each of the scales feet.

1. Place the platform into the correct position.
2. Place the bolt-down plate under the foot.
 - The plate edge extends out from under the scale.
 - Ensure the thru holes for the bolts are outside the frame of the scale
3. Drill **two (2) 7/16"** attachment holes using a hammer drill.
4. Insert anchors with the nut and washer already on them.
5. Tap the anchor into the hole, then tighten the nuts securely.
6. Repeat this process for each plate.



NOTE: *If ramps are **not** installed and bolt-down plates are needed, then a full set of four bolt-down plates are required.*

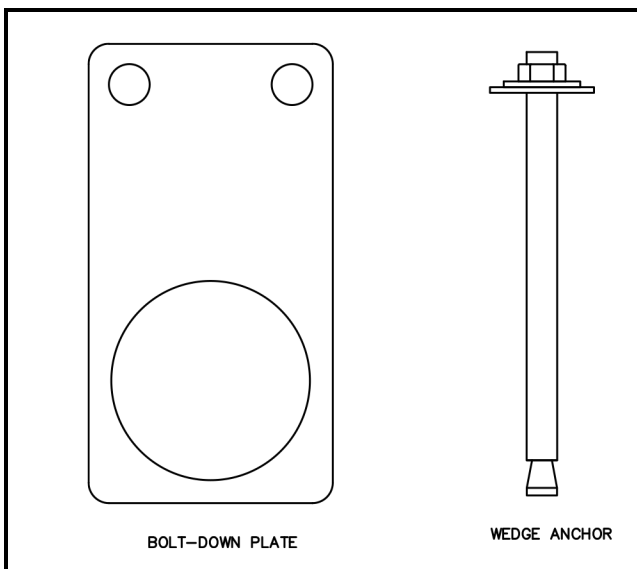

3.2. INSTALLING RAMPS

Each Mild Steel Ramp Accessory comes with two (2) integral bolt-down plates and (4) four anchors.

1. Place the ramp in position, then lift and set the platform feet into the bolt-down plate holes.
2. Drill the **two (2) 7/16” holes** using a hammer drill. Insert the anchors with the nut and washer already on.
3. Tap the anchor into the hole, then tighten the nuts securely.

IMPORTANT TIPS

- If two ramps are installed, then no other bolt-down plates are needed.
- If only one ramp is installed, then a set of two bolt-down plates *are* necessary.
- Only two (2) ramps (total) may be installed on opposite sides of a scale platform.

3.3. INSTALLING BUMPER GUARDS

Bumper Guards help protect the platform from direct hits from forklift traffic. The guards are slightly higher than the scale and help deflect the forks.

1. Place the bumper guard into a position so it protects the platform from non-scale traffic.
 - Neither should touch or interfere with the platform’s movement.
2. Drill the **7/16”** fastening holes using a hammer drill.
3. Insert the anchors with the nut and washer already on it.
4. Tap the anchor into the hole.
5. Tighten the nuts securely.

3.4. INSTALLING PIT FRAMES

The pit frame accessory is a one-piece welded unit. There are three (3) different types of frames, each with six (6) sizes.

- Two (2) are for the standard duty scale and one (1) is for the heavy capacity.
- The Pit Frame is designed for in-floor, or 'flush', applications.
- Standard duty frames are available in mild steel for all six floor scale sizes

For normal installations, cut a square hole in the concrete, install the pit-frame accessory into this hole, then pour concrete around and under the frame.

- The concrete work and frame setting is usually completed by a contractor.
- A scale technician completes the project by setting and installing the scale.
- Once installed, no additional welding is required.

1. Place the pit frame in the approximate position it will occupy on the floor.
2. Mark the position of the hole to be made.
 - The hole **must** be a minimum of **twelve inches (12") wider** on all sides than the pit frame.
 - The hole will have to be deep enough to accommodate the pit coping, plus the thickness of the pit floor.
 - Use the drawing in **Appendix IV** for measurements.
 - Should pit drainage be required, slope the pit floor to an installed drain while maintaining a level area at each corner.
3. Cut the hole in the concrete floor.
4. Clean up any debris in the way of further installation steps.
5. Set the frame in the hole supported at about the correct height.
6. Set two 2x4 's on the top edge (longer than the width of the hole) across the opening.

3.4. INSTALLING PIT FRAMES, CONTINUED

7. Use soft wire and make **two (2) loops** by twisting wire around each 2x4 and the frame.

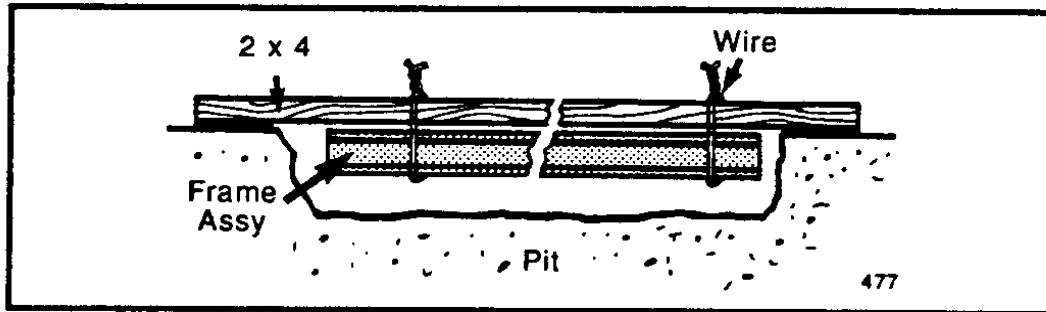

8. With the frame supported by the wire and 2x4's, use a level to set the frame flush with the surrounding floor, level, and at the correct height by twisting or untwisting the wire.

NOTE: Use the drawing in **Appendix IV** for measurements, concrete specifications and amounts.

9. Set into place and secure the conduit for the scale cable into the frame opening.
10. Pour the concrete around and under the frame.
11. Level and smooth it with a hand trowel, as needed.
12. If a drain is required, form the pit to place a slope in the pit floor to the drain.
 - See Appendix IV.
 - Allow cement to cure to a **minimum of 2000 psi** before cutting the wire.
13. Pull the cable through the conduit before placing the scale platform in the frame.
14. Level the platform before installing the instrumentation.

Section 4: Parts Replacement

4.1. LOAD CELL REPLACEMENT

1. **Cycle-down the power** to the indicator, then unplug the unit.
2. Remove the platform and junction box access covers.
3. Disconnect the failed load cell cable(s) at the junction box.
4. Loosen the gland bushing, and tie a string or wire to the end of the cable to act as a pull wire.
5. Place wire markers on the cable ends.
 - Masking tape is an effective alternative
6. Disconnect the faulty load cells wires from the terminal block.
7. Lift the platform end with a forklift or heavy pry bar, using wood blocks for safety.
8. Remove the load cell mounting bolts with a **3/4" socket**.
9. Remove the load cell, pulling the cable through the scale while leaving the pull string/wire in the scale.
10. Remove the foot assembly from the old cell, then install it onto the new load cell.
 - Use anti-seize on the threads.
11. Disconnect the pull string/wire from the old cell's cable, then attach to the new cell's cable end.
12. Pull the cable from the new cell through to the junction box.
13. Mount the cell to the scale platform.
 - Torque it to **90 ft/lbs**, using anti-seize on the mounting bolts.
14. Lower the scale to the surface removing the safety blocks.
15. Distribute the scale's weight evenly by all four (4) feet.
16. Connect the load cell wires into the junction box, then tighten the box gland bushing(s).
17. Replace the platform access cover.
18. Replace the box cover and torque all screws to **18-20 in/lbs**.
19. Recalibrate the unit as necessary.

IMPORTANT NOTE: See [Appendix I](#) for specific load cell color code and wiring information.

4.1.1. Load Cell Specifications

DESCRIPTION	SPECIFICATION
Material	Mild Steel
Rated Output	3mV/V
Impedance	350 ohm
Safe Overload	150%
Compensated Temperature Range	-10° C to 40° C
Safe Operating Temperature Range	-10° C to 40° C

4.2. JUNCTION BOX REPLACEMENT STEPS

1. **Cycle-down the power** to the indicator, then unplug the unit.
2. Open the platform access cover.
3. Open the junction box cover.
4. Loosen all gland bushing nuts.
5. Place wire markers on all the load cell cable ends.
6. Disconnect the load cells' wires from the terminal blocks.
7. Disconnect the homerun wires.
8. Remove the PCB, clean the junction box, then install the new PCB.
9. Reconnect all load cell and home-run wires to the new PCB.
10. Tighten all gland bushing nuts.

IMPORTANT NOTE: *Leave the junction box cover **off** until all corner adjustments are completed.*

11. Replace the junction box cover, and torque all screws to **18-20 in/lbs.**
12. Replace the platform access cover.
13. Recalibrate the unit as necessary.

4.3. FOOT ASSEMBLY REPLACEMENT STEPS

1. Lift the platform end with a forklift or heavy pry bar using wood blocks for safety.
2. Remove the hole plug over the foot to be replaced.
3. Using a standard screwdriver, unscrew the foot assembly.
4. Replace the Foot Assembly, using anti-seize on the screws attaching to the load cell.
5. Lower the scale to the surface removing the safety blocks.
6. Distribute the scale's weight evenly by all four (4) feet.
7. Replace the hole plug in the access hole.

Section 5: Parts

5.1. PARTS LIST

ITEM	PART NO.	DESCRIPTION	SCALE CAPACITIES
1	----	Platform Weldment	----
2	58925*	1K lb Capacity Load Cell	Both 1K, 2.5K
2	12896*	2.5K lb Capacity Load Cell	5K
2	63593*	5K lb Capacity Load Cell	10K
3	66754	Load Cell Shim	ALL
4	63913	Foot Assembly, Knuckle Ball Mild Steel	ALL
5	54502	Load Cell Mounting Bolt, 1/2" – 20 x 1-3/4"	ALL
6	67171M	Analog Junction Box	ALL
*	96141	PCB for Analog Junction Box	ALL
11	12838	Cable Assembly	ALL
12	17546	Liquid Tight Connector	ALL
13	63586	Hole Plug, 5/8"	ALL
14	54203	SS Hex Nut, 10-24 (for ground)	ALL
15	14721	5" Velcro Loop (use with hook)	ALL
16	14722	5" Velcro Hook (use with loop)	ALL
17	11175	Rubber Bushing (for #11 connection)	ALL

* See [Appendix I](#) for Load Cell wiring information.

NOTE: *If the complete assembly is required (both the Junction Box and Board), order part number **67171M** as the new style replacement.*

5.2. PARTS DIAGRAM

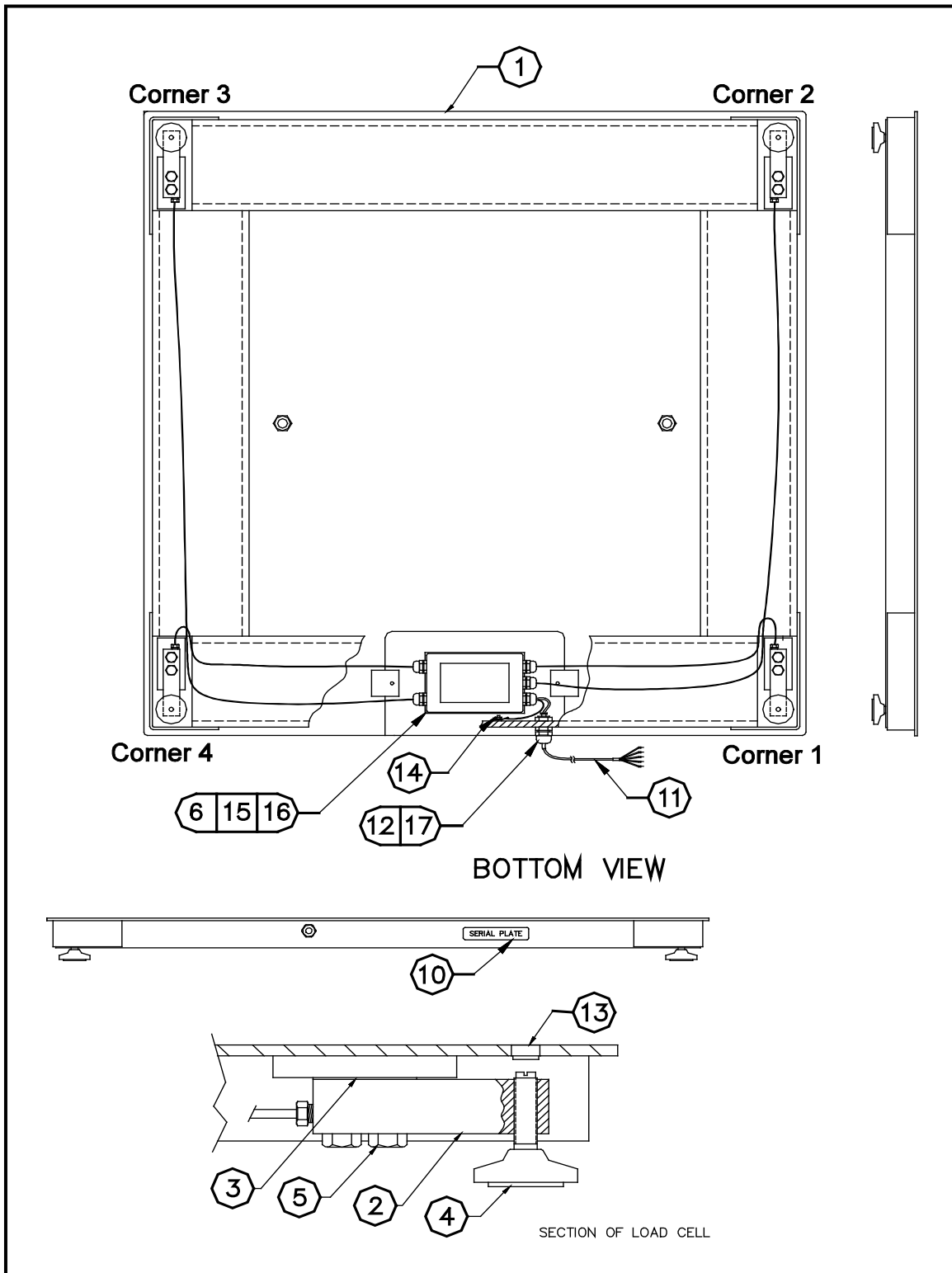

Appendix I: Load Cells

Some scale models were manufactured with different brands of load cells, which have different wiring color codes schemes. Wire the load cells according to the following charts.

TABLE A

ITEM	PART NO.	DESCRIPTION	SCALE CAPACITY
2	58925	1K lb Capacity Load Cell 350 Ohm, 3 mV/V, Plated Tool Steel	Both 1K, 2.5K
2	12896	2.5K lb Capacity Load Cell 350 Ohm, 3 mV/V, Plated Tool Steel	5K
2	63593	5K lb Capacity Load Cell 350 Ohm, 3 mV/V, Plated Tool Steel	10K

TABLE A WIRING

WIRE COLOR	FUNCTION
Black	(-) Excitation
Red	(+) Excitation
Yellow	Shield
Green	(+) Signal
White	(-)Signal

TABLE B

ITEM	PART NO.	DESCRIPTION	SCALE CAPACITY
2	107003	1K lb Capacity Load Cell 350 Ohm, 3 mV/V, Plated Tool Steel	Both 1K, 2.5K
2	107004	2.5K lb Capacity Load Cell 350 Ohm, 3 mV/V, Plated Tool Steel	5K
2	107005	5K lb Capacity Load Cell 350 Ohm, 3 mV/V, Plated Tool Steel	10K

TABLE B WIRING

WIRE COLOR	FUNCTION
Black	(-) Excitation
Green	(+) Excitation
Yellow	Shield
White	(+) Signal
Red	(-)Signal



PRODUCT: 3013-06 –POTTED LOAD CELLS AND FOOT

PART NO.	DESCRIPTION	LCF NO.	SCALE CAP.	FOOT ASSY
63889	1K Stainless Steel, Potted, Beam Cell, Blind Hole	LCF-HR4050-2	1k, 2.5k	63899
63890	2.5K Stainless Steel, Potted, Beam Cell, Blind Hole	LCF-HR4050-3	5k	63899
63891	5K Stainless Steel, Potted, Beam Cell, Blind Hole	LCF-HR4050-4	10k	63899

PRODUCT: 3002-02 BLIND HOLE LOAD CELLS AND FOOT

PART NO.	DESCRIPTION	LCF NO.	SCALE CAP.	FOOT ASSY
63895	1K Stainless Steel, Hermetic, Beam Cell, Blind Hole	LCF-HR4060-2	1k, 2.5k	63899
63896	2.5K Stainless Steel, Hermetic,, Beam Cell, Blind Hole	LCF-HR4060-3	5k	63899
63897	5K Stainless Steel, Hermetic,, Beam Cell, Blind Hole	LCF-HR4060-4	10k	63899

PRODUCT: 3016-12 CAPTIVE BALL FEET

PART NO.	DESCRIPTION
63914	Captive Ball Foot Assembly Mild Steel 1-5k capacities

Appendix II: Model Matrix

PRODUCT NO.	SIZE	CAPACITY	PLATFORM WELDMENT
63606	3' x 3"	1000 lbs	63489
63607	3' x 3'	2500 lbs	63489
63608	4' x 4'	2500 lbs	63491
63609	4' x 4'	5000 lbs	63491
63610	4' x 4'	10,000 lbs	63491
63611	4' x 5'	5000 lbs	63523
63612	4' x 5'	10,000 lbs	63523
63613	4' x 6'	5000 lbs	63525
63614	4' x 6'	10,000 lbs	63525
63615	5' x 5'	5000 lbs	63493
63616	5' x 5'	10,000 lbs	63493
63617	5' x 7'	5000 lbs	63495
63618	5' x 7'	10,000 lbs	63495
63667	6' x 8'	10,000 lbs	22484

Appendix III: Accessories

A. RAMPS, BUMPER GUARDS AND PIT FRAMES

SIZE	CAPACITY	RAMP*	Bumper Guard	PIT FRAME
30" x 30"	1000 lbs	64058 (30")	-----	82908
3' x 3"	1000 lbs	63751 (3')	72198 (3')	63757
3' x 3'	2500 lbs	63751 (3')	72198 (3')	63757
4' x 4'	2500 lbs	63753 (4')	72194 (4')	63759
4' x 4'	5000 lbs	63753 (4')	72194 (4')	63759
4' x 4'	10,000 lbs	63753 (4')	72194 (4')	63759
4' x 5'	5000 lbs	63753 (4') 63755 (5')	72194 (4') 72190 (5')	63761
4' x 5'	10,000 lbs	63753 (4') 63755 (5')	72194 (4') 72190 (5')	63761
4' x 6'	5000 lbs	63753 (4') 64060 (6')	72194 (4') 72196 (6')	63763
4' x 6'	10000 lbs	63753 (4') 64060 (6')	72194 (4') 72196 (6')	63763
5' x 5'	5,000 lbs	63755 (5')	72190 (5')	63765
5' x 5'	10000 lbs	63755 (5')	72190 (5')	63765
5' x 7'	5,000 lbs	63755 (5')	72190 (5') 72192 (7')	63767
5' x 7'	10000 lbs	63755 (5')	72190 (5') 72192 (7')	63767
6' x 8'	10,000 lbs	64060 (6')	72196 (6') 72200 (8')	64062
-----	-----	86467 (4')**	-----	-----
-----	-----	154033 (5')**	-----	-----

*Standard Ramps are at a 5° grade

**Ramps are at a 3.5° grade

B. BOLT-DOWN PLATES, EYEBOLTS AND HOLE PLUGS

SIZE	CAPACITY	BOLT-DOWN PLATES	EYEBOLTS	EYEBOLT HOLE PLUGS
ALL	ALL	63777 (Set of 4)	70895 (Set of 2)	70896 (Set of 2)
		63779 (Set of 2)		

Appendix IV: Pit Frame Installation

MILD STEEL		PLATFORM SIZE		STAINLESS STEEL	
MS MODEL / PART NO.	OLD No.	A	B	SS MODEL / PART NO.	OLD No.
ACC-1728 / 63757	92849	3' X 3'	3'	ACC-H1728 / 63746	92849-S
ACC-1729 / 63759	92850	4' X 4'	6'	ACC-H1729 / 63760	92850-S
ACC-1730 / 63761	92851	4' X 5'	7'	ACC-H1730 / 63762	92851-S
ACC-1732 / 63763	92853	4' X 6'	8'	ACC-H1732 / 63764	92853-S
ACC-1734 / 63765	92855	5' X 5'	7'	ACC-H1734 / 63766	92855-S
ACC-1736 / 63767	92854	5' X 7'	9'	ACC-H1736 / 63768	92854-S
ACC-1741 / 64062	93188	6' X 8'	10'	ACC-H1741 / 64063	93188-S

MILD STEEL		PLATFORM SIZE		STAINLESS STEEL	
MS MODEL / PART NO.	OLD No.	A	B	SS MODEL / PART NO.	OLD No.
79264		2'-0" X 3'-1"	4'-0" 7'-1"		
		2'-5" X 4'-2"	4'-5" 6'-5"	79864	
		2'-5" X 5'-0"	4'-5" 7'-0"	80042	
		3' X 3'	5'		
80242		4' X 4'-0"	6'	8'-5"	
81561		4' X 4'-0"	6'	8'-5"	
82518		2'-5" X 2'-5"	4'-0" 4'-5"	23537	
		5' X 5'	7'	83947	
84098		5' X 5'	7'	92169	

SOME OF THE SPECIAL PIT INSTALLATIONS

NOTE:

- A PIT FRAME IS ONE-PIECE WELDED UNIT AND FIELD WELDING REQUIRED.
- THE PIT DIMENSIONS ARE DETERMINED BY THE PIT FRAME ACCESSORIES.
- AT LEAST 6" THICKNESS OF CONCRETE IS REQUIRED FOR PIT FLOOR.
- ON NON-HOSTILE APPLICATIONS:
- A. MINIMUM CONCRETE FLOOR WITH MINIMUM 3" BOTTOM SLOPES SHOULD BE REQUIRED. DRAINAGE IS REQUIRED FOR HOSTILE APPLICATION. A 4" DIA. DRAIN IS RECOMMENDED.
- A. SOIL BEARING PRESSURE OF AT LEAST 1,000 LB PER SQUARE FT. IS REQUIRED. THE CORNER PIER SHOULD BE DESIGNED TO SUPPORT AT LEAST TWO THIRDS OF THE TOTAL CAPACITY OF THE SCALE.
- A 3/4" DIA. CONDUIT FOR SCALE INTERFACE CABLE IS RECOMMENDED. THE PIT FRAME IS ASSEMBLED WITH A 1 1/8" DIA. HOLE FOR CABLE EXIT.
- WITH THE FRAME LEVEL(S) IN BOTH DIRECTIONS, AND SECURED, CONCRETE IS FILLED IN AROUND THE OUTSIDE OF PIT FRAME AND PIT FLOOR TO FORM SCALE PIT. IT IS RECOMMENDED THAT $f_c=3000$ PSI AND 3" TO 4" SLUMP CONCRETE BE USED.
- WHEN THE CONCRETE HAS REACHED A MINIMUM OF 2000 PSI, PULL THE INTERFACE CABLE THROUGH THE CONDUIT TO THE INSTRUMENT LOCATION, AND LOWER THE PLATFORM ASSEMBLY INTO POSITION.
- THE PLATFORM AND PIT COPIES SHOULD BE 1/4" TO 3/8".

NO.	BY	DATE	REVISION
1.	JMH	8/11/00	RELEASED
2.	JMH	10/23/02	CHANGED SCALE FOOT LOCATIONS

FAIRBANKS SCALES
 Version: 04/2002

PIT INSTALLATION
 1 - 1K MS AND SS
 AEGIS BASIC & PROFILE

DATE: 8/11/00
 DRAWN BY: JSH
 CHECKED BY: JSH
 APPROVED BY: JSH
 PART NO.: 21896

The material used for construction shall be the property of Fairbanks Scales and shall be used in accordance with the specifications and drawings. No part of this document shall be reproduced without the prior written permission of Fairbanks Scales.

Appendix V: Scale Modifications

A. AVAILABLE MODIFICATIONS LIST

- Nonstandard floor scale dimensions
- Smooth deck
- Mild steel lifting handle
- Nonstandard size ramp
- Ramp with smooth surface
- Nonstandard size bumper guards
- Nonstandard size pit frame
- ACC 2801 Intrinsically Safe controller (FB2550 or FB3000 II Instruments)
- ACC 2802 Intrinsically Safe controller (2800 Series Instrument)
- QMB Intalogix™ technology
- Stainless steel “true” hermetically sealed load cells
- Stainless steel potted sealed load cells
- Lower capacity load cells

B. MODIFICATION DESCRIPTIONS

PRODUCT: 3000-02

Floor Scales with Non-standard dimensions

- Available only on floor scales between 30” x 30” and 6’ x 8’ in size.
- Determine floor scale dimensions required. Example: 4.5’ x 6.25’
- Calculate the square feet.
- Round up to the next square foot of a standard floor scale. 5’ x 7’ = 35 sq. ft.
- Some platform sizes and capacities may not be NTEP Approved.

PRODUCT: 3001-02

Floor Scales with Smooth deck

PRODUCT: 3002-02

Stainless Steel “True” Hermetically Sealed Load Cell with blind hole, including feet, LCF-HR4060



B. MODIFICATION DESCRIPTIONS, CONTINUED

PRODUCT: 3004-02

Floor Scales with ACC 2801 Intrinsically Safe Controller (FB2550 or FB3000 II Instruments)

- Includes ACC 2801 ISC
- Interface cable and Instrument is not included.

PRODUCT: 3005-02

Floor Scales with ACC 2802 Intrinsically Safe Controller (2800 Series Instrument)

- Includes ACC 2802 ISC
- Interface cable and Instrument is not included.

PRODUCT: 3006-03

Floor Scales with non-standard Ramp dimensions

- Floor Scale Ramps are sized in one foot increments.
- Round the non-standard dimensional size ramp up to the nearest standard ramp size.

PRODUCT: 3007-03

Floor Scales with non-standard Pit Frame dimensions

- Floor Scale pit frames are priced by the square foot.
- Round the non-standard dimensional size pit frame up to the nearest standard pit frame size square foot.

PRODUCT: 3008-03

Floor Scales with non-standard Bumper Guard dimensions

- Round up to the nearest standard size Bumper Guard.

PRODUCT: 3009-03

Mild Steel Floor Scale with built-in Lifting Handles.

- Handle opening is 5.75”h x 8.92”w.



PRODUCT: 3011-03

Floor Scale with Ramp with Smooth Surface

PRODUCT: 3012-03

Floor Scale with Lower Capacity Load Cells

PRODUCT: 3013-06

Stainless Steel Potted Load Cell with Blind Hole, including feet, LCF-HR4050



B. MODIFICATION DESCRIPTIONS, CONTINUED

PRODUCT: 3014-06

Floor Scale with Intalogix™ Technology

- Included: Stainless steel NEMA 4X QMB (Quad Multiplexer board) and 27' interface cable.
- Instrument not included.

PRODUCT: 3015-11

Floor Scale stainless steel load cell with welded covers and threaded ball-in-cup load cell foot

- Floor scale will use the same capacity load cell as standard product.

PRODUCT: 3016-12

Replace existing knuckle ball foot with threaded ball-in-cup foot

- Available only on 1-10k capacity floor scales.
- Available only on 3' x 3' – 6' x 10' floor scales.

Appendix VI: ACC 3000-1A QMB

A. COMPONENT DESCRIPTION

The **Accessory ACC-3000-1A (15291) Quad Multiplexer Box** interfaces between floor scale platforms and Intalogix® Indicators with a QMB Interface.

This accessory consists of the following components.

- Enclosure with five water tight connectors installed.
- A/D PC Board
- Twenty-seven foot (27') Interface Cable.

B. INSTALLATION

1. Number the load cells on the platform.
 - The Indicator recognizes **Cells 1 and 2** as a pair, **Cells 3 and 4** as a pair.
 - It is recommended that the cells be numbered on top of the platform during installation to avoid mistakes.
2. Bring the load cell cables from Cells 1, 2 and 3 through the liquid tight glands, into the Quad Multiplexer Box.
3. Dress and tin the load cell cables and attach the wires to the marked connectors.
4. Bring the load cell cable from cell 4 into the Quad Multiplexer Box, dress and tin the wire ends.
5. Attach the wires to the marked connector.
6. Install a cable between the Quad Multiplexer Box and the indicator. If necessary dress and tin the wires.
7. Bring the cable end into the indicator and connect to TB2 on Board 15423 QMB Interface PCB in the Intalogix Indicators.

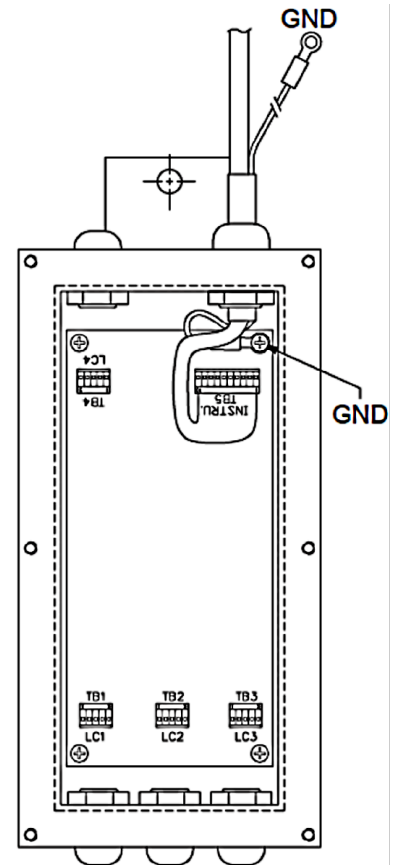

- No adjustments are made in the box.
- All adjustments to the load cells are made through the indicator

C. WIRING

WIRE COLOR	DESCRIPTION	TB2 INSTRUMENT
Green	Exc -	1
Red	Exc +	2
Black	Ground	3
White	D Out	4
Brown	D IN	5
Blue	EOC	6
Orange	SCLK	7
Yellow	CS	8
Violet	Temperature	9
Gray	Chassis	Case Screw

LOAD CELL WIRING	TB1, 2, 3, & 4
Exc -	1
Exc +	2
Shield	3
Signal -	4
Signal +	5

D. GROUNDING

The QMB box-end of the indicator cable is factory installed with a connector.

1. Drill a hole into the platform, if necessary to properly ground the unit.
2. Clean the area around the hole so that there is good electrical contact between the box and the platform.
3. Secure the ground wire that exits through a gland bushing, to a box mounting bolt.

- Store any excess load cell cable.
- Install the gasket and cover on the **ACC 3000-1A QMB**.
- The QMB must be grounded to the platform by attaching the box to the frame with bolts.

A T T E N T I O N

To ensure the QMB Box is water tight, torque all cover bolts to 18-20 inch lbs/in. Doing this compresses the gasket securely.



E. PARTS LIST

PART NO.	DESCRIPTION
15658	Box, Network
15635	PC Board
15659*	Cover
15660	Gasket
17533	Connector, Liquid Tight
12189	Wire Seal
15709	Complete Assembly, Less PC Board
15286	Cable Assy, Instrument
15652	Ring, "O" (Liquid Tight Connector)

Appendix VII: ACC 2801

A. INTRODUCTION

The **2801 Accessory**, Intrinsically Safe Controller (ISC), interfaces up to four (4) analog load cells while installed in a Hazardous Area.

- It operates through an Intrinsically Safe Interface Box (ISIB), Acc 2825, located in the Safe Area with either the FB2550 instruments or the FB3000 series, also located in the Safe Area.
- The ISC contains four (4) A-D Processors for converting load cells' analog outputs into a digital signal.
- The ISC is contained in a stainless steel box with six (6) gland bushings for load cells and interconnection cables.

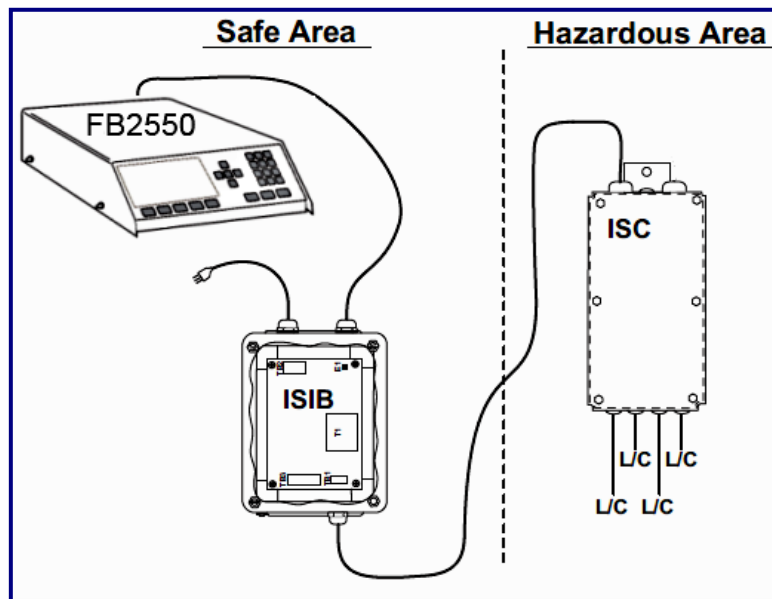

A T T E N T I O N !

Factory Mutual (FM) Approval is issued with strict guidelines. DO NOT, under any circumstances, change or modify any FM-approved equipment, cable, or procedure.

B. WIRING LOAD CELLS

- Mount the scale with the ISC in the Hazardous area where it is accessible and protected.
- Number each analog load cell and bring the properly routed cables through the gland bushings for **TB3 thru TB6**.

TB3, TB4, TB5, TB6	DESCRIPTION
1	(-) EXC
2	(+) EXC
3	SHIELD
4	(+) SIG
5	(-) SIG

CELL	PORT
1	TB3
2	TB4
3	TB5
4	TB6

NOTES:

All cabling should have a "drip loop" at the cell and box to help prevent liquid entry.

On all boxes, the gland bushings have "O" rings that can be forced out of position if the bushing itself is not tight.

- *To prevent this, first tighten the inner nut securing the gland bushing in the hole, then insert the cable and carefully tighten the gland nut with pliers.*
- *Do not over-tighten where the gland bushing 'turns'.*

*The cover **MUST** be secured with ALL screws tightened properly (**18-20 in/lbs**) for protection against moisture and for Factory Mutual (FM) specifications.*

C. WIRING ISC TO ISIB:

- **TB1** interfaces the **ISC** to the **ISIB**.
- Use only **Cable 21737 (2875 Accessory)** for connections between the **ISIB** and **ISC**.

Maximum Cable Lengths ISIB to the ISC:

350 Ohm Cells	1000 Ohm Cells
400 ft	500 ft

Instrument to ISIB Cable Length = **Maximum 50 feet.**

NOTE: Cable lengths are nominal and may need to be reduced for proper operation.

DO NOT EXCEED MAXIMUM CABLE LENGTHS.

D. ISC SWITCH SETTINGS:

S1-1	S1-2	S1-3	S1-4
ON	ON	OFF	ON

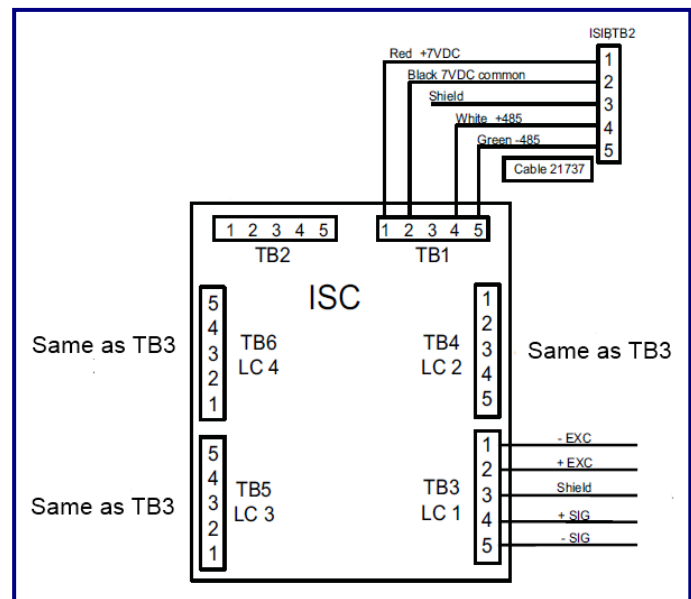

E. GROUNDING

The **ACC 2801** must be grounded to the platform by attaching the box to the frame with bolts.

1. Drill a hole into the platform, if necessary, to properly ground the unit.
 2. Clean the area around the hole so that there is good electrical contact between the box and the platform.
 3. Secure the ground wire that exits through a gland bushing, to a box mounting bolt.
- Store any excess load cell cable.
 - Install the gasket and cover on the **ACC 2801 ISC**.

NOTE: *Once all connections are complete, tighten all gland bushings with pliers. Place the gasket in proper position then secure box cover with all screws torqued to **18-20 inch/lbs**.*

F. PARTS LIST

PART NO.	DESCRIPTION
18460	Box, Assembly
20164	Paired PC Boards
18461	Cover
18462	Gasket
18465	Connector, Liquid Tight
12189	Wire Seal
17533	Connector, Liquid Tight
15652	Ring, "O" (Liquid Tight Connector)
18454	Ring, "O" (Liquid Tight Connector)

Appendix VIII: ACC 2802

A. INTRODUCTION

The **2802 Accessory**, Intrinsically Safe Controller (ISC), interfaces up to four (4) analog load cells while installed in a Hazardous Area.

- It operates through an Intrinsically Safe Interface Box (ISIB), Acc 2825, located in the Safe Area with an Intrinsically Safe 2800 Model Instrument.
- The ISC contains four (4) A-D Processors for converting load cells' analog outputs into a digital signal.
- The ISC is contained in a stainless steel box with six (6) gland bushings for load cells and interconnection cables.

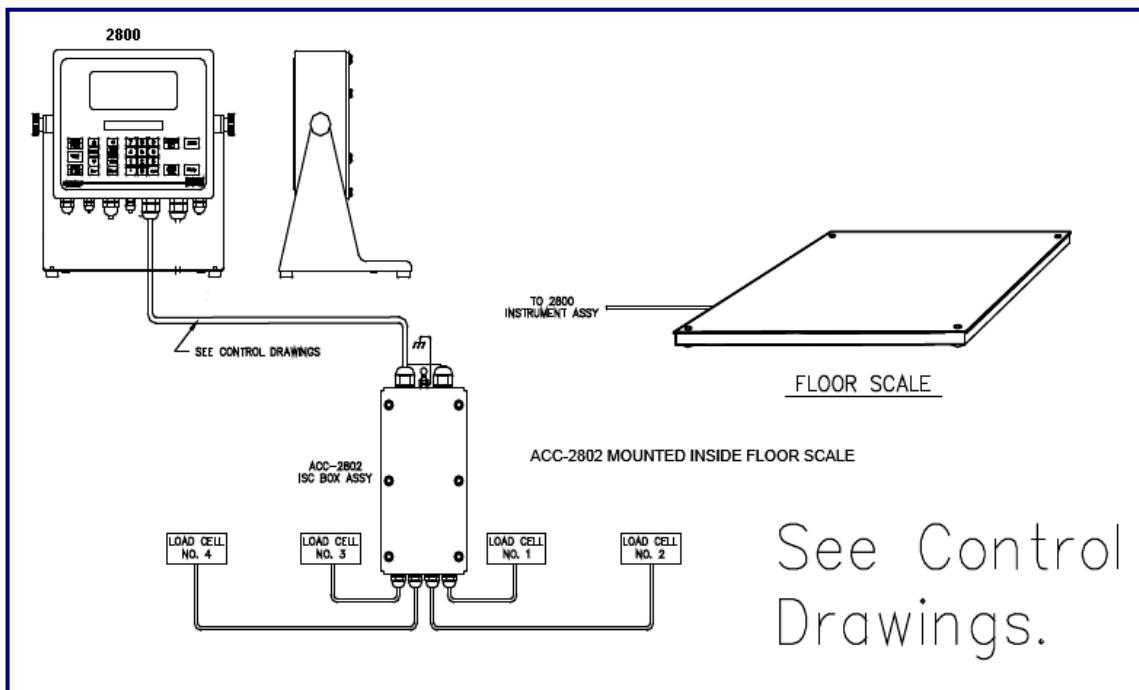

A T T E N T I O N !

Factory Mutual (FM) Approval is issued with strict guidelines.
DO NOT, under any circumstances, change or modify any FM-approved equipment, cable, or procedure.

B. INTERFACE CONNECTION LAYOUT

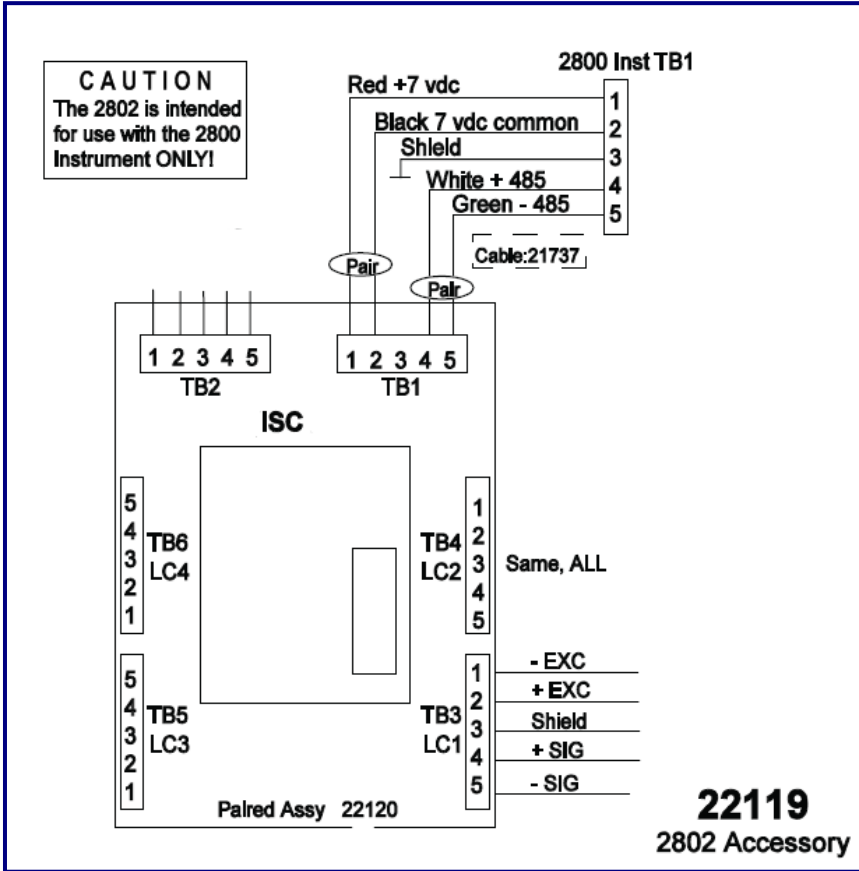

C. WIRING LOAD CELLS

- Mount the scale with the ISC in the Hazardous area where it is accessible and protected.
- Number each analog load cell and bring the properly routed cables through the gland bushings for **TB3 thru TB6**.

TB3, TB4, TB5, TB6	DESCRIPTION
1	(-) EXC
2	(+) EXC
3	SHIELD
4	(+) SIG
5	(-) SIG

CELL	PORT
1	TB3
2	TB4
3	TB5
4	TB6

C. WIRING LOAD CELLS, CONTINUED

NOTES:

All cabling should have a "drip loop" at the cell and box to help prevent liquid entry.

On all boxes, the gland bushings have "O" rings that can be forced out of position if the bushing itself is not tight.

- To prevent this, first tighten the inner nut securing the gland bushing in the hole, then insert the cable and carefully tighten the gland nut with pliers.
- Do not over-tighten where the gland bushing 'turns'.

The cover **MUST** be secured with ALL screws tightened properly (**18-20 in/lbs**) for protection against moisture and for **Factory Mutual (FM)** specifications.

D. ISC SWITCH SETTINGS:

S1-1	S1-2	S1-3	S1-4
ON	ON	OFF	ON

E. GROUNDING

The **ACC 2802** must be grounded to the platform by attaching the box to the frame with bolts.

1. Drill a hole into the platform, if necessary, to properly ground the unit.
 2. Clean the area around the hole so that there is good electrical contact between the box and the platform.
 3. Secure the ground wire that exits through a gland bushing, to a box mounting bolt.
- Store any excess load cell cable.
 - Install the gasket and cover on the **ACC 2802 ISC**.

NOTE: Once all connections are complete, tighten all gland bushings with pliers. Place the gasket in proper position then secure box cover with all screws torqued to **18-20 inch/lbs**.



F. PARTS LIST

PART NO.	DESCRIPTION
18460	Box, Assembly
22120	Paired PC Boards
18461	Cover
18462	Gasket
18465	Connector, Liquid Tight
12189	Wire Seal
17533	Connector, Liquid Tight
15652	Ring, "O" (Liquid Tight Connector)
18454	Ring, "O" (Liquid Tight Connector)



Manufactured by Fairbanks Scales, Inc.
821 Locust
Kansas City, MO 64106

www.fairbanks.com

Aegis Industrial Floor Scale

INSTALLATION MANUAL

DOCUMENT 51102