

FAIRBANKS®

INTERCOM SYSTEM



Fairbanks' Intercom System includes a Communications Controller, (top, left) Station Selector (right) and Call Station transmitter.

RAPID CALL IDENTIFICATION

Fairbanks' Intercom System's LCD Readout allows the operator to quickly identify a call's point of origin. The inbound Call Organizing feature automatically presents customer calls in the order in which they were received. The Dispenser Zoning provides the ability to organize and identify call stations.

SPECIAL FEATURES

- Users share call stations between multiple positions without confusion.
- Priority Station Programming places priority calls (such as primary scale) in front of other calls.
- Auto Standby disconnects a station connection if it is left on by mistake.
- Hold recall automatically reminds the operator about calls on hold.
- As your business grows, the system can be expanded.

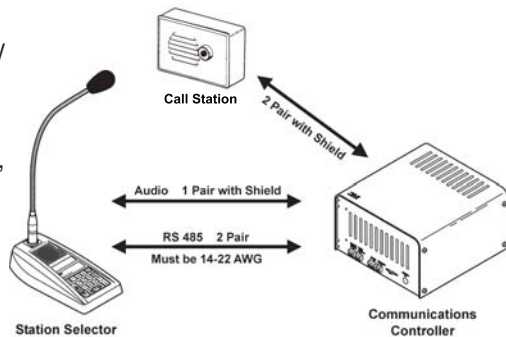

SPECIFICATIONS

Operation modes	Standby Listen Talk All call Off line
Operating keypad	0-9 Left and right scroll arrows Up and down scroll arrows Hold Talk All call Standby
Display	2 line, 16 character per line, backlit LCD
Display character size	0.25" x 0.1875"
Volume control	15 levels
Expansion capability	Up to 8 station selectors and 20 call stations
Power requirements	117 VAC ± 15 % 50/60 Hz
Mounting options	Desk or wall mount

DIMENSIONS

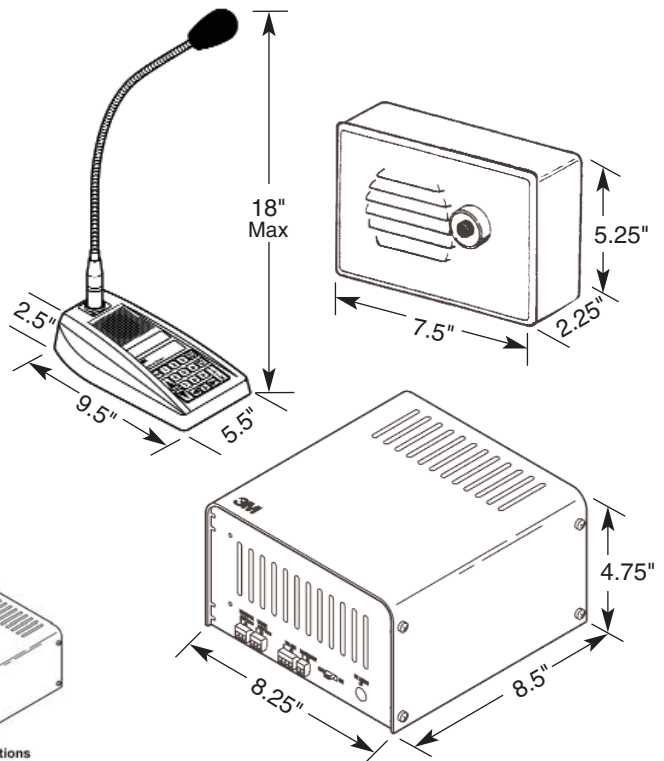

QuickFacts™

Models and specifications subject to change without notice.
Printed in the USA. © Fairbanks Scales Inc.

Call toll-free for the Fairbanks representative nearest you:

(800) 451-4107