

FAIRBANKS®

CS 500 POWER SUPPLY



The CS 500 provides professional-grade power protection for scale equipment and office systems. Battery powered and surge protected power outlets, built-in phone/fax/modem line protection (DSL compatible) and proactive audio-visual status indicators, ensure valuable data is protected from dangerous power surges, spikes and blackouts.

FEATURES

- Battery-protected outlets
- Surge-only protected outlets
- Power conditioning
- Safety agency approved
- Audible alarms
- Overload indicators: Audible alarms; Alarm when on battery; Distinctive low-battery alarm; and Overload continuous tone
- Automatic restart of loads after UPS shutdown
- Automatic self-test
- LED status indicators
- Resettable circuit breakers

RUN TIME BY LOAD

Watts	50	100	200	300	Full	Half
VAC	80	160	320	480	Load	Load
Run Time	56 min.	23 min.	6 min.	1 min.	1 min. (300 Watts)	12 min. (150 Watts)

SPECIFICATIONS:

Nominal Voltage/Frequency	120V
Nominal Output Voltage	120V
Output Power Capacity	300 Watts/ 500 VA
Maximum Configurable Power	300 Watts/ 500 VA
Output Connections	(3) NEMA 5-15R (battery back-up) (3) NEMA 5-15R (surge protection)
Input Frequency	50/60 Hz +/- 5 Hz (auto sensing)
Cord Length	6 ft. (1.83 meters)
Input Voltage Range	98-140V (for main operations)
Surge Protection/Filtering	
Energy Rating	480 Joules
Noise Filtering	Full-time multi-pole
IEEE Surge Let-through	5%
Clamping Response Time	0
Data Line Protection	RJ-11 Modem/Fax/DSL protection (two wire single line)
Rating	Meets UL 1449
Battery	Leak-proof, free sealed, lead-acid
Battery Recharge Time	8 hours
Approvals	FCC Part 15, Class B; Industry Canada; UL 1778; cUL listed

DIMENSIONS (IN INCHES)

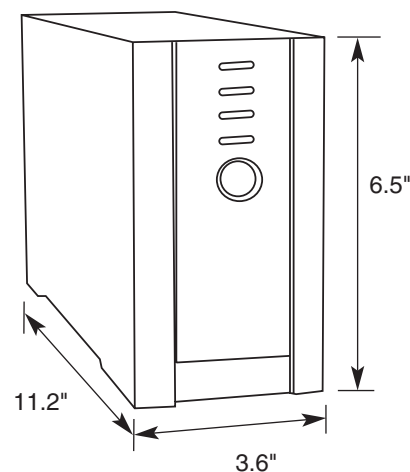

QuickFacts™

Models and specifications subject to change without notice.
Printed in the USA. © Fairbanks Scales Inc.

Call toll-free for the Fairbanks representative nearest you:

(800) 451-4107

Internet Address: <http://www.Fairbanks.com>