

# FAIRBANKS®

## ULTEGRA® BAGGAGE SCALE



Fairbanks Scales' Ultegra Baggage Scale is a perfect solution for today's airline industry because its proven, rugged design is being used in hundreds of applications worldwide.

### BUILT FOR TODAY'S TECHNOLOGY NEEDS

The Ultegra Baggage Scale's USB output easily interfaces with PCs, no outdated RS232 serial interface required. All summing and programming information is contained within the scale platform, no need to find room to house external devices.

### REMOTE DISPLAY COMES STANDARD WITH SCALE

A panel mount remote display is included with the purchase of each Ultegra Baggage Scale. Additional remote displays are sold separately.

### FEATURES

- Easy installation, setup and calibration
- 1.5" tall display characters
- Scale can accommodate up to 4 remote displays
- Additional panel mount or desk mount remote displays sold separately
- Remote display without front panel buttons sold separately
- USB interface
- Custom sizes available
- Adjustable hard rubber feet
- Commercially approved (U.S. and Canada)
- RoHS compliant

### SPECIFICATIONS

Capacity . . . . .	250 lbs (113 kg)
Division size . . . . .	0.2 lbs (0.1 kg)
Platform size . . . . .	31" x 31" (custom sizes available)
Platform height . . . . .	2.31"
Construction	
Base . . . . .	Mild steel, black powder coat
Platform . . . . .	304 Stainless steel, brushed
Output . . . . .	USB (includes 6' cable), RJ45 (remote display)
Power . . . . .	USB or USB to AC power adaptor
Display . . . . .	1.5" tall, 7-segment LCD, panel or desk mount
Units . . . . .	Pounds, kilograms
Front panel keys . . . . .	Units, Zero
Accessories . . . . .	Remote display, remote display splitter
Approvals . . . . .	NTEP CC# 98-198; MC# AM-5785, RoHS compliant

### DIMENSIONS

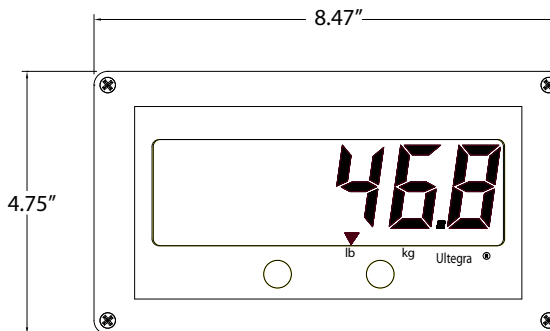
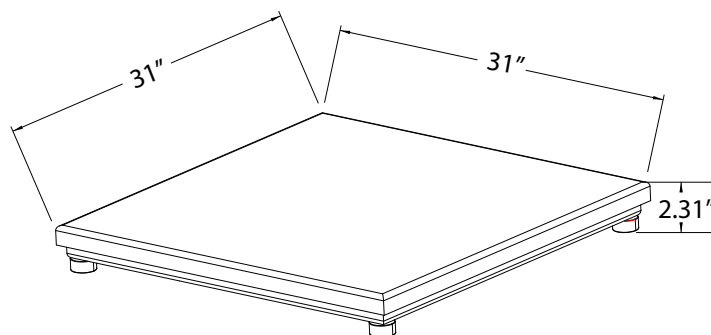

Panel mount remote display

### QuickFacts™

Models and specifications subject to change without notice.  
Printed in the USA. © Fairbanks Scales Inc.  
www.Fairbanks.com



St. Johnsbury manufacturing  
facility registered in  
compliance with ISO 9001.

Call toll-free for the Fairbanks representative nearest you:  
**(800) 451-4107**